

# VISOR<sup>®</sup> object sensor

In a class of its own.

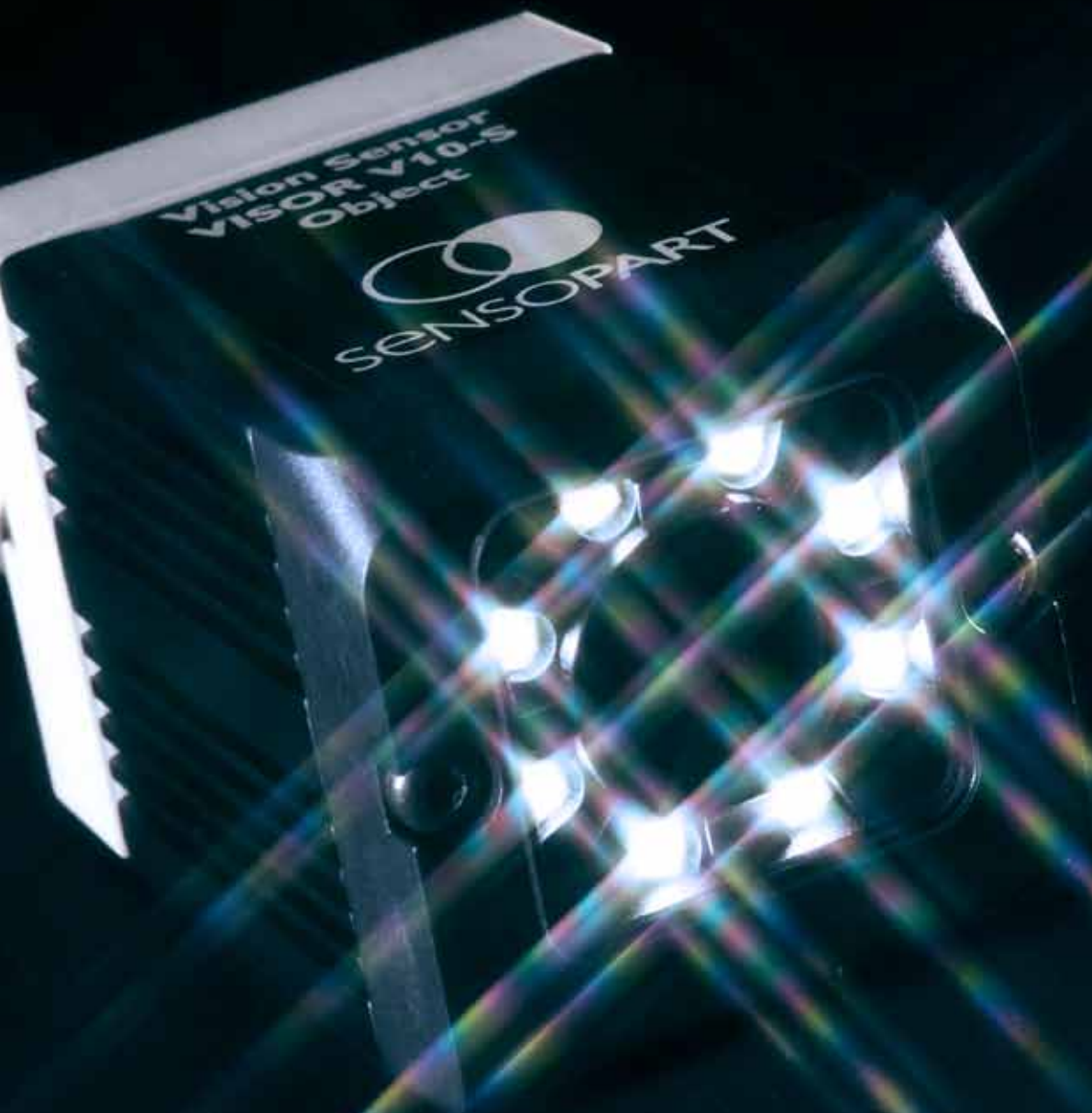

1.3 Mpx

# VISOR® V10 object sensor

Standard vision sensor for object detection, 12 mm



## PRODUCT HIGHLIGHTS

- User-friendly configuration and viewer software with hierarchical user rights
- Detectors for object detection
- Powerful part-finding and tracking
- Precise position determination: X/Y-position and orientation
- Comprehensive logic functions for digital switching outputs

Optical data		Functions	
Resolution	736 x 480 pixels	Number of jobs / detectors	8 / 32
CMOS	1/3", monochrome	Detectors	Contour; pattern comparison, contrast, brightness, grey level
Integrated lens, focal length	12 mm, adjustable focal position	Properties	Position tracking: X/Y and orientation; Pattern comparison / contour: teach-in and detection of patterns and contours; grey threshold, brightness: evaluation of brightness; contrast: evaluation of contrast
Adjustment range	30 mm to infinity	Typical cycle times	Typ. 20 ms pattern comparison Typ. 30 ms contour Typ. 2 ms brightness Typ. 2 ms contrast Typ. 2 ms grey threshold
Integrated illumination	White, red, infrared LEDs		
Minimum field of view, X x Y	8 x 6 mm <sup>2</sup>		
Electrical data		Mechanical data	
Operating voltage, +U <sub>b</sub>	18 ... 26.4 V DC <sup>1</sup>	Dimensions	65 x 45 x 45 mm <sup>3</sup> (without plug)
Current consumption (without illumination and I/O)	≤ 120 mA	Enclosure rating	IP 67
Current consumption (without I/O)	≤ 200 mA	Material, housing	Aluminium, plastic
Protective circuits	Reverse-polarity protection, U <sub>b</sub> / short-circuit protection of all outputs	Material, front screen	Plastic
Power On Delay	Ca. 13 s after Power on	Ambient temperature: operation	0 ... +50 °C <sup>2</sup>
Outputs	PNP / NPN (switchable)	Ambient temperature: storage	-20 ... +60 °C <sup>2</sup>
Max. output current (per output)	50 mA, 100 mA (pin 12)	Weight	Ca. 160 g
Inputs	PNP/NPN High > U <sub>b</sub> -1 V, Low < 3 V	Plug connections	Supply and I/O M12, 12-pin Ethernet M12, 4-pin
Input resistance	> 20 kOhm	Vibration and impact resistance	EN 60947-5-2
Interfaces	Ethernet (LAN), EtherNet/IP, PROFINET		
Inputs/outputs	2 inputs, 4 outputs, 2 selectable inputs/outputs		

<sup>1</sup> Max. ripple < 5V<sub>SS</sub>    <sup>2</sup> 80 % air humidity, non-condensing

Illumination	Depth of field	Part number	Article number
White	Normal	V10-OB-S1-W12	535-91009
Red	Normal	V10-OB-S1-R12	535-91011
Infrared	Normal	V10-OB-S1-I12	535-91047

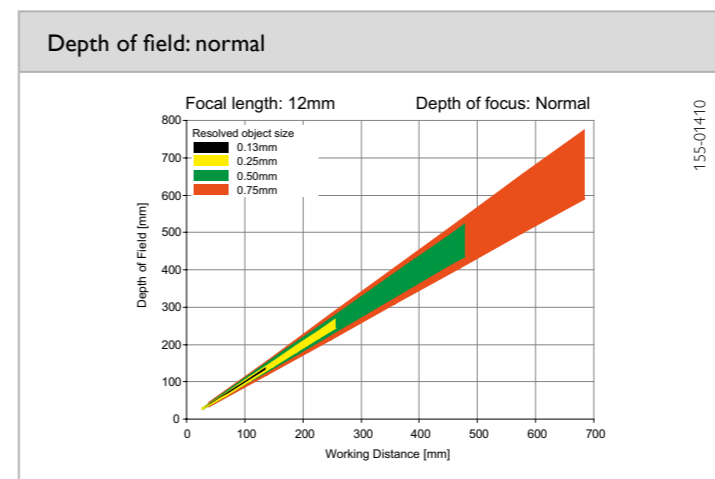
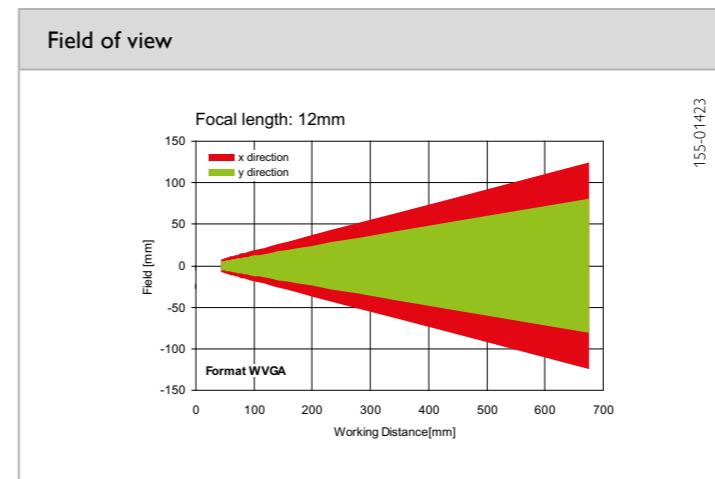
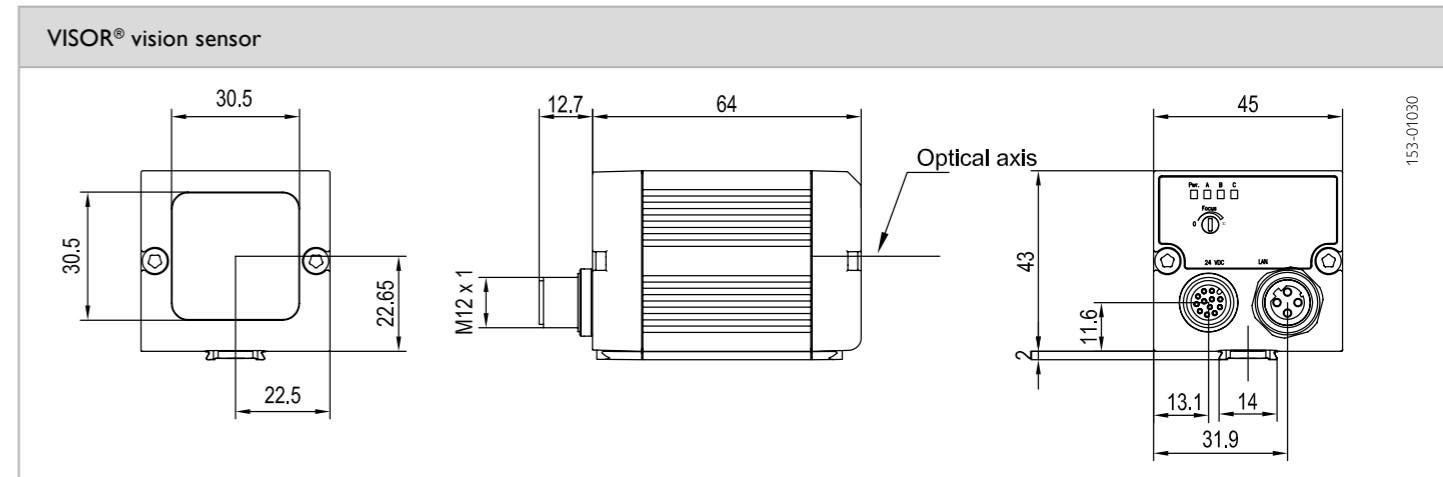

Accessories	
Connection cables	See product catalog/ accessories
Illumination	
Brackets	
Interface accessories	