

UM 2/R-170 Return Unit



- For conveyor unit self-assembly
- Conveyor medium: accumulation roller chain (suitable for use in an EPA)

- For use in conjunction with all AS 2/R-... drive modules and ST 2/... sections
- Design with pinion for return unit recommended for sections of $l = 6000$ mm or for sections of any length for reversible operation

Product description

The return unit is used to set up conveyor units. It guides the conveyor medium at the end of the conveyor unit back to the drive module.

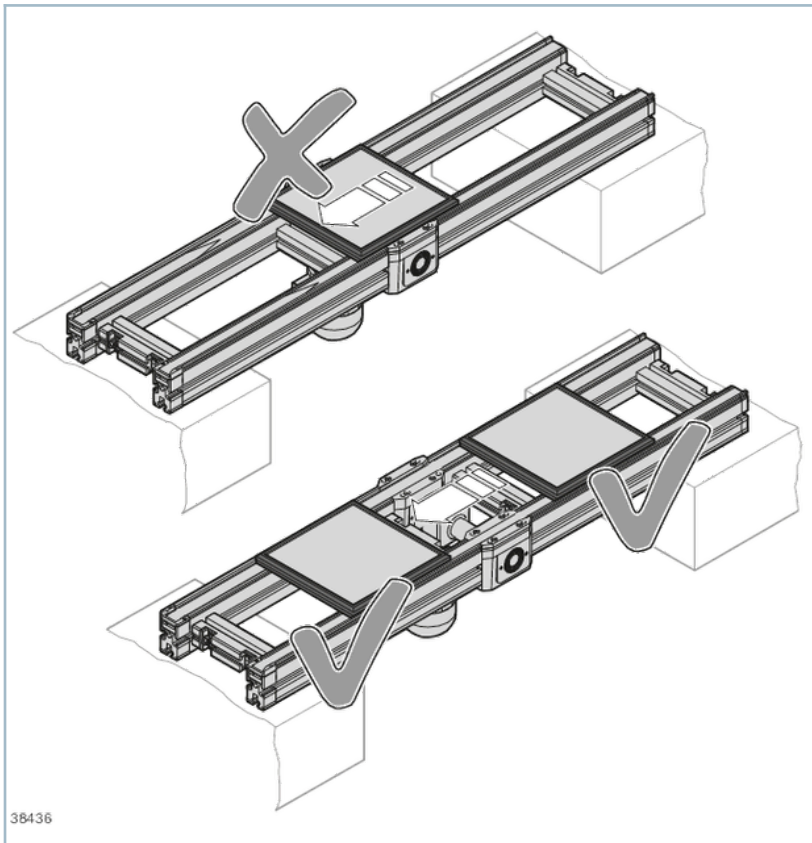

Technical data

No.			3842528807
ESD			yes
Required conveyor media length	l_{UM}	mm	310

Dimensions

UM 2/R... return unit

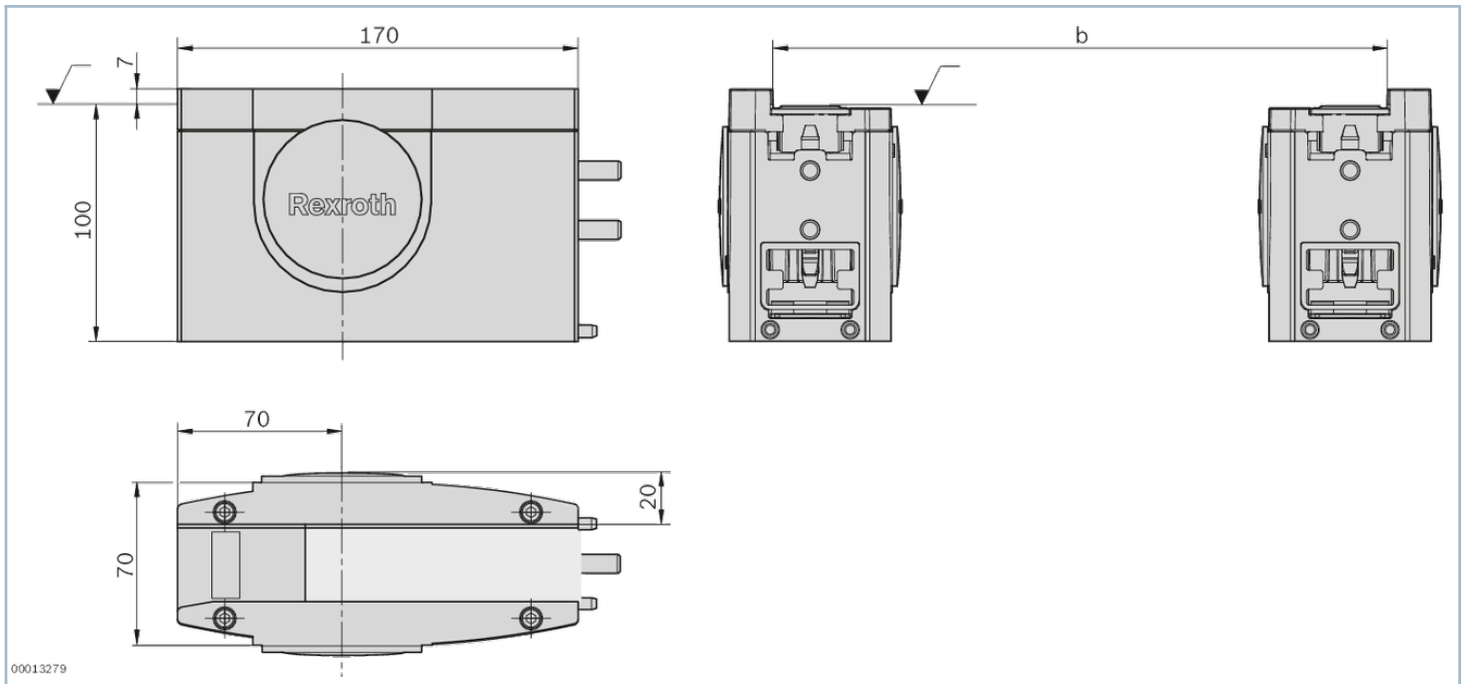

Delivery notes

Condition of Delivery

Fully assembled

Ordering codes

	No.
UM 2/R-170 Return Unit	3842528807