



COMPANY WITH
QUALITY SYSTEM
CERTIFIED BY DNV GL
= ISO 9001 =

SNODI SFERICI • TESTE A SNODO • FORCELLE
SPHERICAL PLAIN BEARINGS • ROD ENDS • CLEVISSES



CATALOGO TECNICO GENERALE
GENERAL TECHNICAL CATALOGUE



01.01.18

www.isb-bearing.com

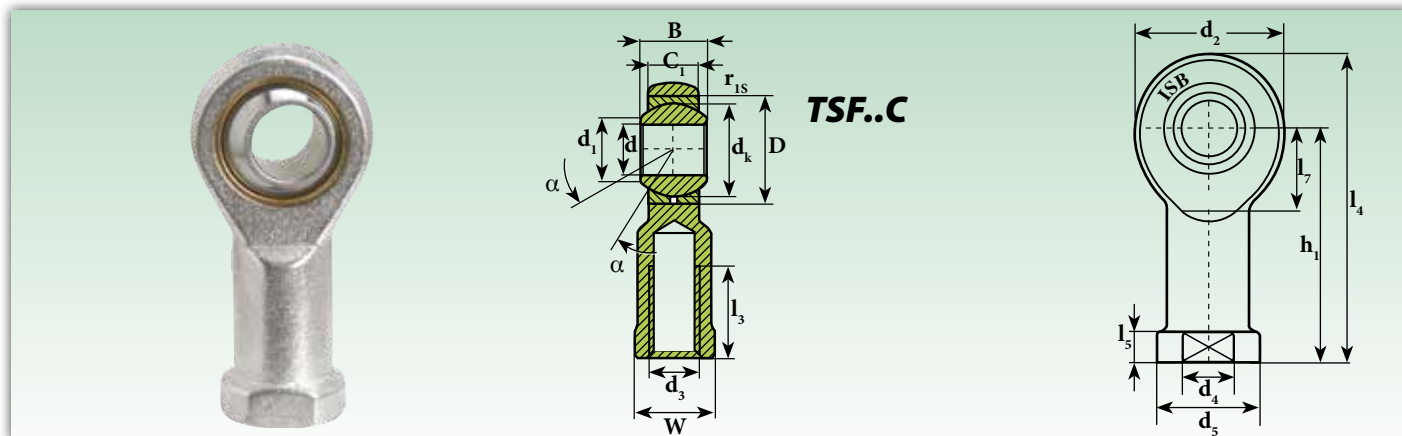

Sigla ¹⁾ Designation ¹⁾	Dimensioni mm Dimensions mm																Gradi Degrees ≈ α	Distanza dagli spigoli Distance from edges (mm.) r _{15min}	Carico Ratings load		Peso Weight ≈ Kg
	d H7	d ₁	d ₂	d ₃	d ₄	d ₅	d _k	B	C ₁	D	h ₁	l ₃ *	l ₄	l ₅	l ₇	W			Dinamico C Dinamyc C KN	Statico C ₀ Static C ₀ KN	
TSF 5 C	5	7,7	18	M 5x0,8	9	12	11,11	8	7,5	13	27	8	36	4	10	10	13	0,3	3,2	5,2	0,01
TSF 6 C	6	8,9	20	M 6x1	10	13	12,70	9	7,5	16	30	9	40	5	11	10	13	0,3	4,2	6,7	0,01
TSF 8 C	8	10,3	24	M 8x1,25	12,5	16	15,88	12	9,5	19	36	12	48	5	13	13	14	0,3	7	11,2	0,03
TSF 10 C	10	12,9	28	M 10x1,5	15	19	19,05	14	11,5	22	43	15	58	6,5	15	16	13	0,3	9,6	14,2	0,08
TSF 10.1 C²⁾	10	12,9	28	M 10x1,25	15	19	19,05	14	11,5	22	43	15	58	6,5	15	16	13	0,3	9,6	14,2	0,08
TSF 12 C	12	15,4	32	M 12x1,75	17,5	22	22,23	16	12,5	26	50	18	67	6,5	17	18	13	0,3	13	16,8	0,12
TSF 12.1 C²⁾	12	15,4	32	M 12x1,25	17,5	22	22,23	16	12,5	26	50	18	67	6,5	17	18	13	0,3	13	16,8	0,12
TSF 14 C	14	16,8	36	M 14x2	21	25	25,40	19	14,5	28	57	21	76	8	18	21	16	0,3	16,8	27,4	0,14
TSF 14.1 C²⁾	14	16,8	36	M 14x1,5	21	25	25,40	19	14,5	28	57	21	76	8	18	21	16	0,3	16,8	27,4	0,14
TSF 15 C	15	18,12	36	M 14x2	22	26	26,99	20	15	-	61	22	79	8	-	22	-	0,3	19	28,1	0,19
TSF 16 C	16	19,3	42	M 16x2	22	27	28,57	21	15,5	32	64	24	85	8	23	24	15	0,3	21,2	34,3	0,22
TSF 16.1 C²⁾	16	19,3	42	M 16x1,5	22	27	28,57	21	15,5	32	64	24	85	8	23	24	15	0,3	21,2	34,3	0,22
TSF 18 C	18	21,8	44	M 18x1,5	25	31	31,75	23	17,5	35	71	27	94	10	25	27	15	0,3	25,7	41,4	0,32
TSF 20 C	20	24,3	50	M 20x1,5	27,5	34	34,93	25	18,5	40	77	30	102	10	26	30	14	0,3	31	49,8	0,42
TSF 22 C	22	25,8	54	M 22x1,5	30	37	38,10	28	21	42	84	33	112	12	29	34	15	0,3	37,9	60,5	0,61
TSF 25 C	25	29,5	60	M 24x2	33,5	42	42,85	31	23	47	94	36	124	12	32	36	15	0,3	48,1	65,5	0,81
TSF 28 C	28	32,3	66	M 27x2	37	46	47,59	35	26	-	103	41	136	14	34	41	15	0,3	59,9	71,3	1,20
TSF 30 C	30	34,8	70	M 30x2	40	50	50,80	37	27	55	110	45	145	15	37	46	17	0,3	71,4	80,6	1,40
TSF 35 C	35	39	81	M 36x2	46	58	57,15	43	28	-	125	56	165,5	17	-	50	16	0,3	89,2	97,2	1,70
TSF 40 C	40	-	91	M 42x2	53	65	66,67	49	33	-	142	60	187,5	19	-	55	16	0,3	-	-	2,40
TSF 50 C	50	-	117	M 48x2	65	75	82,5	60	45	-	160	65	218,5	23	-	65	12	0,3	-	-	5,00

**Su richiesta, disponibili in acciaio inox (anello interno AISI 440 C o 420C - anello esterno AISI 316)
Under request, stainless steel available (AISI 440 C or 420C inner ring - AISI 316 outer ring)**

¹⁾ Per filettatura a sinistra aggiungere il suffisso "L" (esempio: TSFL..C)
The shank of ball joint housing may be left-hand thread, for left-hand thread suffix "L" is added (example: TSFL..C)

²⁾ Tipo con filetto CETOP thread type

Accoppiamento di strisciamento: acciaio/PTFE

Sliding coupling: steel/PTFE

TSF..C equivalente a equivalent to: GIKR..-PW INA e and SIKB..F SKF

* Lunghezza minima Minimum length