



TQ 402 and TQ 412 / EA 402 / IQS 450

Proximity measuring system

FEATURES

- » From the Vibro-Meter® product line
- » TQ 402 conforms to API 670 recommendations
- » Non-contact measurement system based on eddy current principle
- » Certified for use in potentially explosive atmospheres
- » 1 m, 5 m and 10 m systems
- » Temperature compensated system
- » Voltage or current output with protection against short circuits
- » Frequency response:
DC to 20 kHz (-3 dB)
- » Measuring range:
2 or 4 mm
- » Temperature range:
-40 to +180°C

TQ 402



TQ 412



IQS 450



DESCRIPTION

This proximity system allows contactless measurement of the relative displacement of moving machine elements. It is particularly suitable for measuring the relative vibration and axial position of rotating machine shafts, such as those found in steam, gas and hydraulic turbines, as well as in alternators, turbo-compressors and pumps.

The system is based around a TQ 402 or TQ 412 non-contact transducer and an IQS 450 signal conditioner. Together, these form a calibrated proximity system in which each component is interchangeable. The system outputs a voltage or current proportional to the distance between the transducer tip and the target, such as a machine shaft.



Information contained in this document may be subject to Export Control Regulations of the European Union, USA or other countries. Each recipient of this document is responsible for ensuring that transfer or use of any information contained in this document complies with all relevant Export Control Regulations. ECN N/A.

DESCRIPTION *(continued)*

The active part of the transducer is a coil of wire that is moulded inside the tip of the device, made of Torlon® (polyamide-imide). The transducer body is made of stainless steel. The target material must, in all cases, be metallic.

The transducer body is available with metric or imperial thread. The TQ 412 version is intended for reverse-mount applications. The TQ 402/412 has an integral coaxial cable, terminated with a self-locking miniature coaxial connector. Various cable lengths (integral and extension) can be ordered.

The IQS 450 signal conditioner contains a high-frequency modulator/demodulator that supplies a driving signal to the transducer. This generates the

necessary electromagnetic field used to measure the gap. The conditioner circuitry is made of high-quality components and is mounted in an aluminium extrusion.

The TQ 402 and TQ 412 transducers can be matched with a single EA 402 extension cable to effectively lengthen the front-end. Optional housings, junction boxes and interconnection protectors are available for the mechanical and environmental protection of the connection between the integral and extension cables.

The proximity system can be powered by associated signal processing modules (for example, VM600 cards) or a rack power supply.

SPECIFICATIONS

Overall proximity system

Operation

Sensitivity

- *Ordering option B21* : 8 mV/μm (200 mV/mil)
- *Ordering option B22* : 2.5 μA/μm (62.5 μA/mil)
- *Ordering option B23* : 4 mV/μm (100 mV/mil)
- *Ordering option B24* : 1.25 μA/μm (31.2 μA/mil)

Linear measuring range (typical)

- *Ordering option B21* : 0.15 to 2.15 mm, corresponding to a –1.6 to –17.6 V output
- *Ordering option B22* : 0.15 to 2.15 mm, corresponding to a –15.5 to –20.5 mA output
- *Ordering option B23* : 0.3 to 4.3 mm, corresponding to a –1.6 to –17.6 V output
- *Ordering option B24* : 0.3 to 4.3 mm, corresponding to a –15.5 to –20.5 mA output

Linearity : See Performance curves on pages 4 and 5

Frequency response : DC to 20 kHz (–3 dB)

Interchangeability of elements : All components in system are interchangeable

Environmental – explosive atmospheres

Available in Ex approved versions for use in hazardous locations

Type of protection Ex i: intrinsic safety (ordering option A2)		
Europe	EC type examination certificate	LCIE 11 ATEX 3091 X II 1G (Zones 0, 1, 2) Ex ia IIC T6 ... T3 Ga
International	IECEx certificate of conformity	IECEx LCI 11.0061X Ex ia IIC T6 ... T3 Ga
North America	cCSAus certificate of compliance	1514309 Class I, Divisions 1 and 2, Groups A, B, C and D Ex ia

 **For specific parameters of the mode of protection concerned and special conditions for safe use, please refer to the Ex certificates that are available from Meggitt SA on demand.**

SPECIFICATIONS (continued)

Type of protection Ex nA: non-sparking (ordering option A3)		
Europe	Voluntary type examination certificate	LCIE 11 ATEX 1010 X II 3G (Zone 2) Ex nA II T6 ... T3 Gc
International	IECEX certificate of conformity	IECEX LCI 11.0063X Ex nA II T6 ... T3 Gc
North America	cCSAus certificate of compliance	1514309 Class I, Division 2, Groups A, B, C, D

 **When using protection mode 'nA' (non-sparking), the user shall ensure that the signal conditioner is installed in an enclosure that ensures a protection rating of at least IP54 (or equivalent).**

 **For specific parameters of the mode of protection concerned and special conditions for safe use, please refer to the Ex certificates that are available from Meggitt SA on demand.**

System calibration

Calibration temperature : +23°C ±5°C
Target material : VCL 140 steel (1.7225)

Note: If special calibration is required, please define the alloy precisely or supply a sample of alloy (min. Ø50 mm / 1 cm thick) according to Meggitt Sensing Systems' drawing number PZ 7009/1.

Total system length

The total system length (TSL) is the sum of the length of the TQ 4xx transducer's integral cable and the length of the EA 40x extension cable. The supported TSLs can be obtained from different combinations of cables.

Total system lengths

- 1 m : 1.0 m integral cable with no extension cable
- 5 m : 0.5 m integral cable + 4.5 m extension cable
1.0 m integral cable + 4.0 m extension cable
1.5 m integral cable + 3.5 m extension cable
2.0 m integral cable + 3.0 m extension cable
5.0 m integral cable with no extension cable
- 10 m : 0.5 m integral cable + 9.5 m extension cable
1.0 m integral cable + 9.0 m extension cable
1.5 m integral cable + 8.5 m extension cable
2.0 m integral cable + 8.0 m extension cable
5.0 m integral cable + 5.0 m extension cable
10.0 m integral cable with no extension cable

The combination of cables selected for a particular total system length depends on the application. For example, to obtain the optimum location for the separation between the integral and extension cables or to eliminate the requirement for an extension cable.

Total system length trimming

Due to the characteristics of the coaxial cable, an "electrical trimming" of the nominal length of extension cables is necessary to optimize the system performance and the transducer interchangeability.

TSL for a 1 m measuring chain : 0.9 m minimum
TSL for a 5 m measuring chain : 4.4 m minimum
TSL for a 10 m measuring chain : 8.8 m minimum

SPECIFICATIONS (continued)

Performance curves for TQ 402 and TQ 412 with IQS 450 (ordering options B21 and B22)

Typical gap error (μm)
(Referenced to 8 mV/ μm
(2.5 $\mu\text{A}/\mu\text{m}$) line)

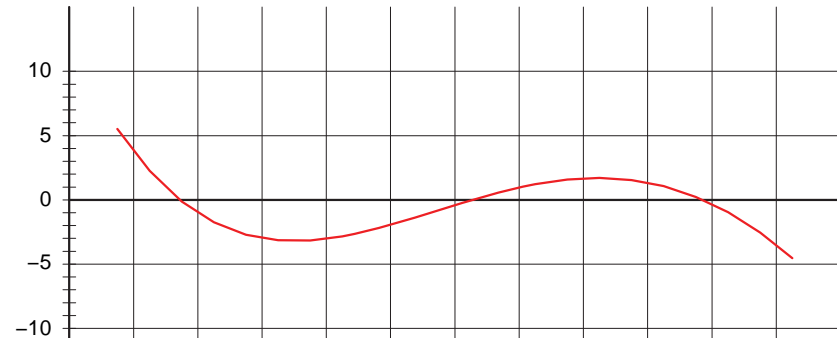

Typical sensitivity error
(Referenced to 8 mV/ μm
(2.5 $\mu\text{A}/\mu\text{m}$))

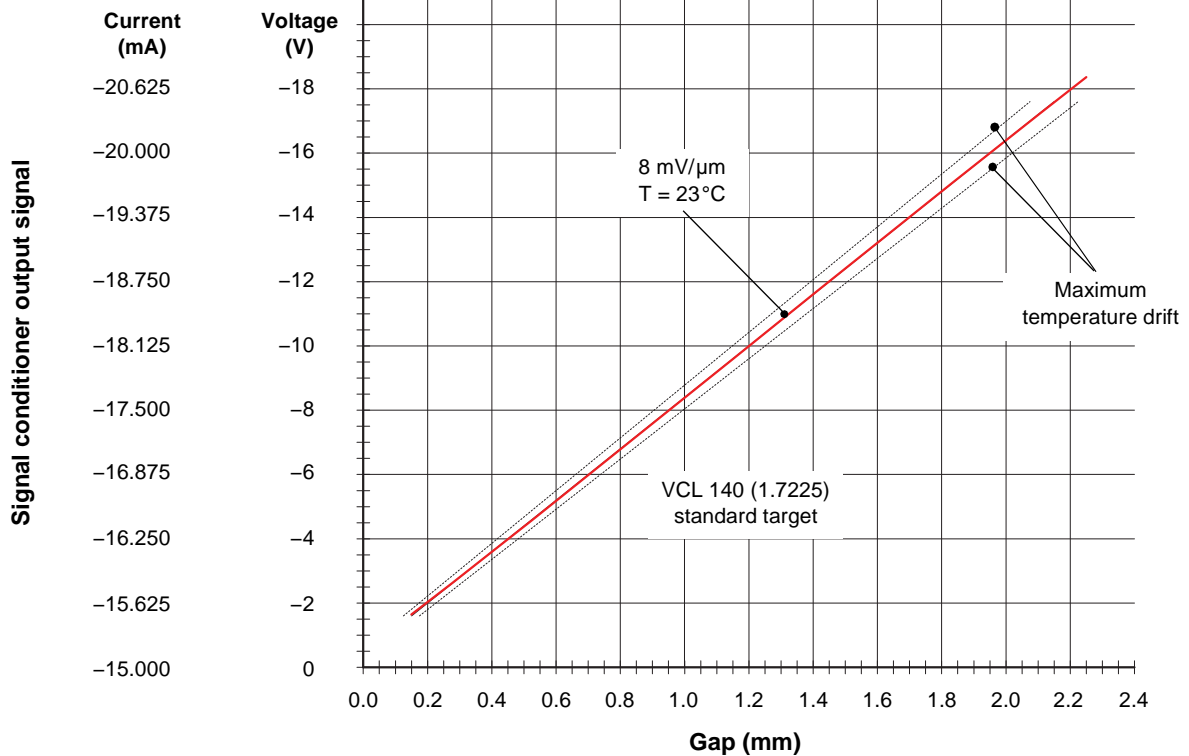
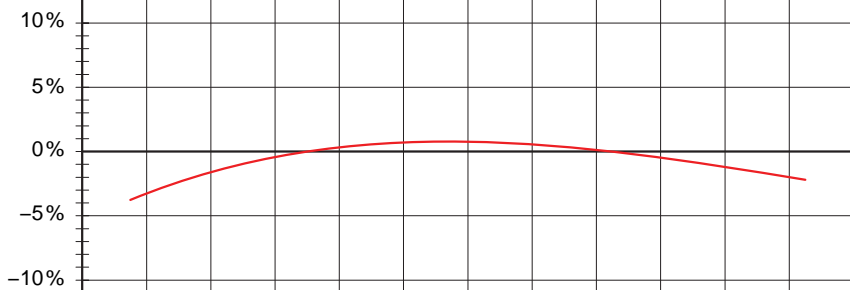

Proximity transducer: TQ 402 / TQ 412
Signal conditioner: IQS 450 (ordering option B21 and B22)
Standard target material: VCL 140 (1.7225)
Equivalent materials: A 37.11 (1.0065), AFNOR 40 CD4, AISI 4140

SPECIFICATIONS (continued)

Performance curves for TQ 402 and TQ 412 with IQS 450 (ordering options B23 and B24)

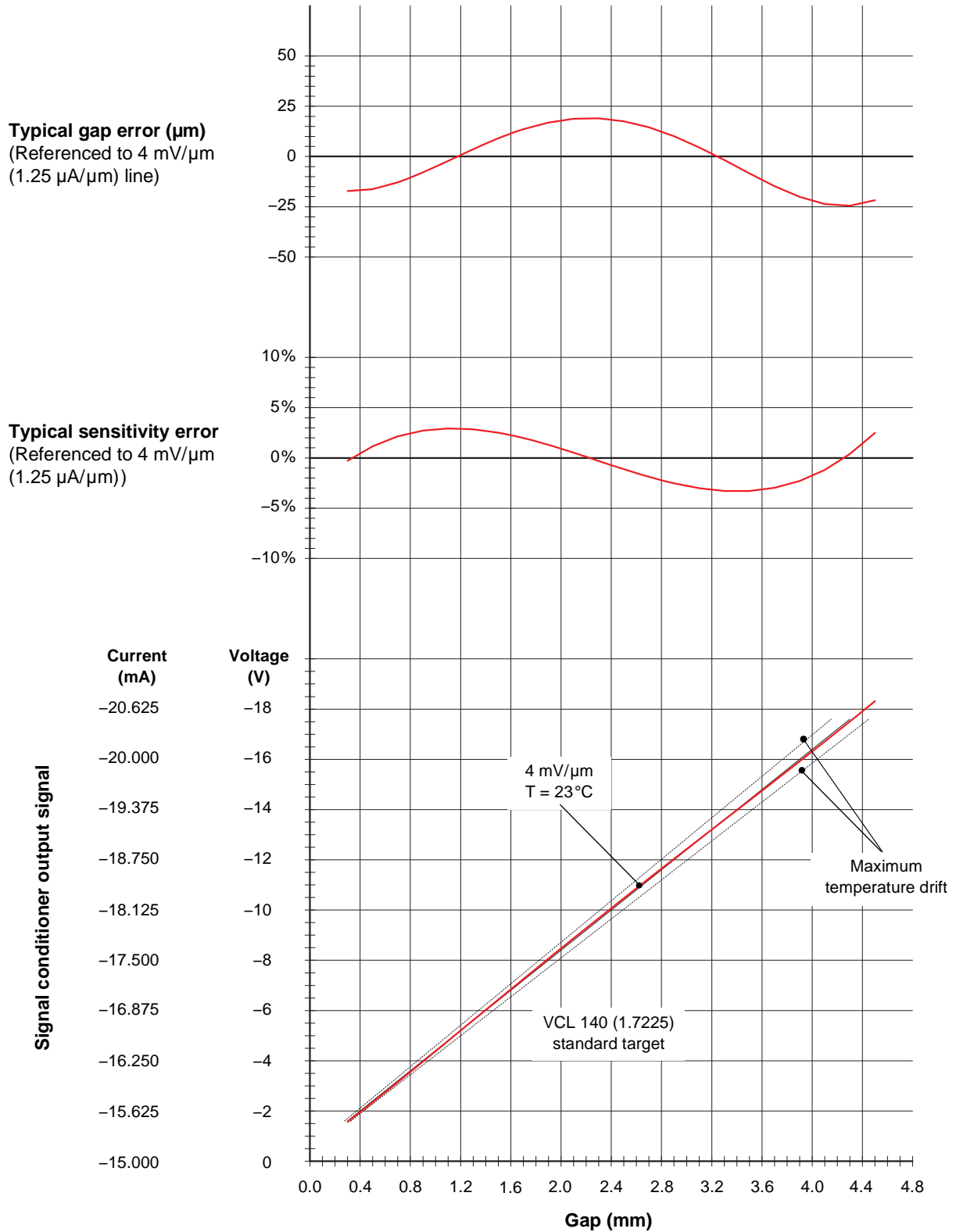

Proximity transducer: TQ 402 / TQ 412
 Signal conditioner: IQS 450 (ordering option B23 and B24)
 Standard target material: VCL 140 (1.7225)
 Equivalent materials: A 37.11 (1.0065), AFNOR 40 CD4, AISI 4140

SPECIFICATIONS (continued)

TQ 402 and TQ 412 proximity transducers and EA 402 extension cable

General

Transducer input requirements : High-frequency power source from an IQS 450 signal conditioner

Environmental

Temperature ranges

- *Transducer* : -40 to +180°C with drift < 5% (operating).
+180 to +220°C with drift > 5% (short-term survival).
 - *Transducer and cable* : **-40 to +195°C if used in an Ex Zone**
 - *Cable, connector and optional protection* : -40 to +200°C
- Protection rating (according to IEC 60529) : The head of the proximity transducer (transducer tip and integral cable) is rated IP68
- Vibration (according to IEC 60068-2-26) : 5 g peak between 10 and 500 Hz
- Shock acceleration (according to IEC 60068-2-27) : 15 g peak (half sine-wave, 11 ms duration)

Physical characteristics

- Transducer construction : Wire coil Ø8 mm, Torlon (polyamide-imide) tip, encapsulated in stainless steel body (AISI 316L) with high-temperature epoxy glue
- Integral and extension cables : FEP covered 70 Ω coaxial cable, Ø3.6 mm
- Connectors : Self-locking miniature coaxial connectors.
Note: When connecting, these should be hand-tightened until locked.
- Optional protection
- *Flexible stainless steel hose (protection tube)* : The stainless steel hose provides additional mechanical protection but is not leak-tight
 - *FEP sheath (extruded fluorinated ethylene propylene)* : The FEP sheath provides resistance to almost all chemicals and low permeability to liquids, gases and moisture. It is also flexible, low friction and mechanically tough.

SPECIFICATIONS (continued)

IQS 450 signal conditioner**Output**

Voltage output, 3-wire configuration

- *Voltage at min. gap* : -1.6 V
- *Voltage at max. gap* : -17.6 V
- *Dynamic range* : 16 V
- *Output impedance* : 500 Ω
- *Short-circuit current* : 45 mA

Current output, 2-wire configuration

- *Current at min. gap* : -15.5 mA
- *Current at max. gap* : -20.5 mA
- *Dynamic range* : 5 mA

Output capacitance : 1 nF

Output inductance : 100 μ H**Supply**

Voltage output, 3-wire configuration

- *Voltage* : -20 to -32 V*
- *Current* : -13 mA \pm 1 mA (-25 mA max.)

Current output, 2-wire configuration

- *Voltage* : -20 to -32 V*
- *Current* : -15.5 to -20.5 mA

Supply input capacitance : 1 nF

Supply input inductance : 100 μ H**Environmental**

Temperature ranges

- *Operating* : -35 to +85°C*
- *Storage* : -40 to +85°C

Humidity : Max. 95% non condensing.
100% condensing (not submerged).Protection rating : IP40
(according to IEC 60529)Vibration : 2 g peak between 10 and 55 Hz
(according to IEC 60068-2-26)Shock acceleration : 15 g peak (half sine-wave, 11 ms duration)
(according to IEC 60068-2-27)**Physical characteristics**

Construction material : Injection moulded aluminium

Mounting : Two or four M4 screws

Dimensions : See Mechanical drawings and ordering information on page 12

* See Thermal considerations on page 8.

SPECIFICATIONS *(continued)*

Electrical connections

Input : Self-locking miniature coaxial connector (female).
Note: When connecting, this should be hand-tightened, until locked.

Output and power : Three screw terminals – wire section 2.5 mm² (max.)

Weight

Standard version : 140 g (approx.)
Ex version : 220 g (approx.)

Signal conditioner with MA 130 mounting adaptor (ordering option I1)

Universal DIN rail holder type : TSH 35
DIN rail type : TH 35-7.5 or TH 35-15
(according to EN 50022 / IEC 60715)

Thermal considerations

The IQS 450 signal conditioner will operate at ambient temperatures as high as 85°C, but to do so, it requires derating of the maximum input voltage. The IQS 450 must operate between the minimum supply voltage and the maximum supply voltage, as shown on the following graph.

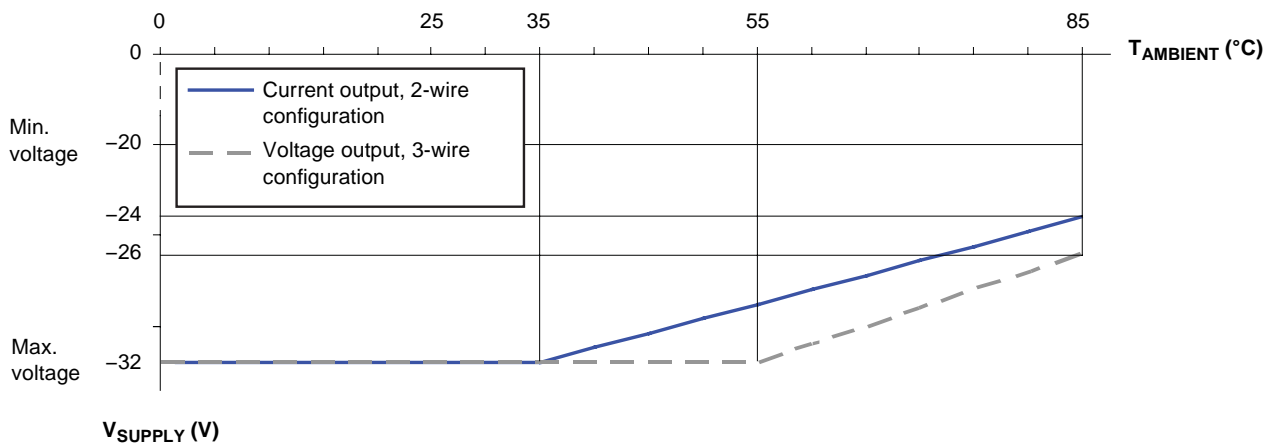

MECHANICAL DRAWINGS AND ORDERING INFORMATION

TQ 402 proximity transducer

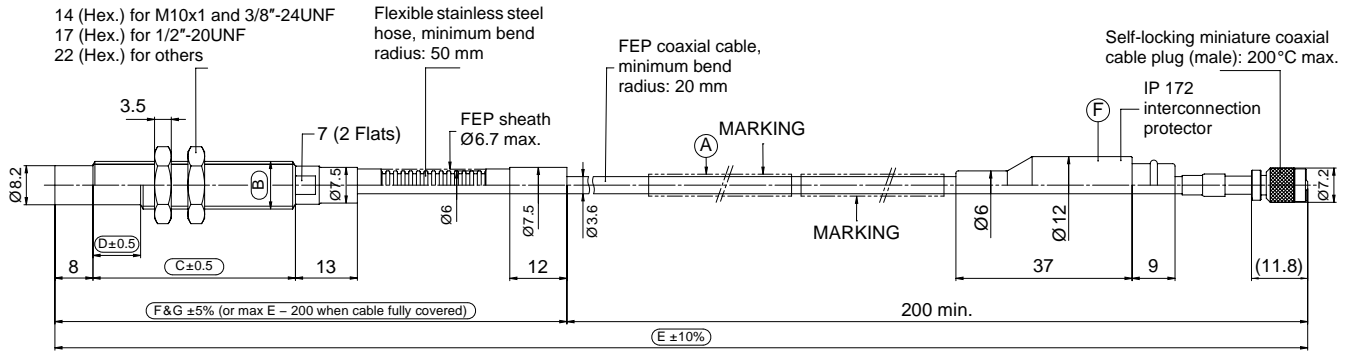

Ordering number:

111 - 402 - 000 - 013 - A B C D E F G H

Environment (A)	
Standard	1
Explosive Ex i	2
Explosive Ex nA	3

Body thread (B)	
M10 x 1	1
M14 x 1.5	2
M16 x 1.5	3
3/8"-24UNF	6
5/8"-18UNF	7
1/2"-20UNF	8

Body length (C)	
Each 1 mm, from 20 to 250 mm	
20 mm min.	020
250 mm max.	250

Unthreaded length (D)	
Each 1 mm, from 0 to 230 mm	
0 mm min.	000
230 mm max.	230

Integral cable length (E)	
0.5 m ±50 mm	005
1.0 m ±100 mm	010
1.5 m ±150 mm	015
2.0 m ±200 mm	020
5.0 m ±500 mm	050
10 m ±1000 mm	100

Total system length (H)	
See note 2	
01	1 m
05	5 m
10	10 m

Flexible hose length (G)	
See note 1	
Each 0.1 m, from 0 to 9.8 m. G min. = C + 100 mm.	
000	None
001	0.1 m min.
098	9.8 m max.

Optional protection (F)		
See note 1		
	Cable	Connector
0	None	None
1	Flexible hose	None
2	Flexible hose with FEP sheath	None
3	Movable flexible hose	None
4	Movable flexible hose with FEP sheath	None
5	None	IP 172
6	Flexible hose	IP 172
7	Flexible hose with FEP sheath	IP 172
8	Movable flexible hose	IP 172
9	Movable flexible hose with FEP sheath	IP 172

Notes

All dimensions are in mm unless otherwise stated.

- When optional protection such as a flexible stainless steel hose with or without an FEP sheath is ordered:
Flexible hose length (G) min. = Body length (C) + 100 mm.
Flexible hose length (G) max. = Integral cable length (E) - 200 mm, for an integral cable that is protected to the maximum extent possible ("cable fully covered").
- The Total system length (H) = Integral cable length (E) + EA 402 extension cable length.
For information on combining integral and extension cables to obtain a particular total system length, see Total system length on page 3. For information on cable length tolerances, see Total system length trimming on page 3.

MECHANICAL DRAWINGS AND ORDERING INFORMATION (continued)

TQ 412 proximity transducer

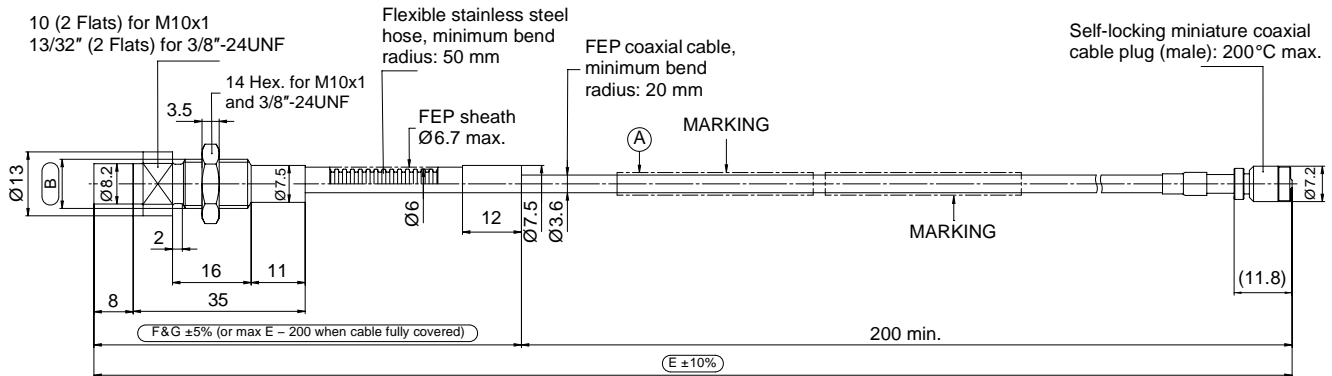

Ordering number: 111 - 412 - 000 - 013 - A - B - E - F - G - H

Environment (A)	
Standard	1
Explosive Ex i	2
Explosive Ex nA	3

Body thread (B)	
M10 x 1	1
3/8"-24UNF	6

Integral cable length (E)	
0.5 m ±50 mm	005
1.0 m ±100 mm	010
1.5 m ±150 mm	015
2.0 m ±200 mm	020
5.0 m ±500 mm	050
10.0 m ±1000 mm	100

Optional protection (F)	
See note 1	
None	0
Flexible hose	1
Flexible hose with FEP sheath	2
Movable flexible hose	3
Movable flexible hose with FEP sheath	4

Total system length (H)	
See note 2	
01	1 m
05	5 m
10	10 m

Flexible hose length (G)	
See note 1	
Each 0.1 m, from 0 to 9.8 m	
000	None
001	0.1 m min.
098	9.8 m max.

Notes

All dimensions are in mm unless otherwise stated.

1. When optional protection such as a flexible stainless steel hose with or without an FEP sheath is ordered:

Flexible hose length (G) max. = Integral cable length (E) – 200 mm, for an integral cable that is protected to the maximum extent possible ("cable fully covered").

2. The Total system length (H) = Integral cable length (E) + EA 402 extension cable length.

For information on combining integral and extension cables to obtain a particular total system length, see Total system length on page 3.

For information on cable length tolerances, see Total system length trimming on page 3.