

## T8400C, T8401C and T8424C,D Electronic Thermostats

### PRODUCT DATA



### FEATURES

- Attractive styling complements any decor to the homeowner's delight.
- Ease-of-use means fewer homeowner questions and increased homeowner satisfaction.
- Large display for quick easy readability.
- Conveniently sized 3-1/2 x 3-1/2 thermostat with optional decorator cover plates (3-7/8 in. x 3-7/8 in. and 5-3/4 in. x 5-3/4 in.) makes it easy to install in a variety of locations.
- Keys are located for easy access.
- Fan and system switches are located on the lower edge to eliminate accidental setting changes.
- Easy installation, setup and self-test saves time and increases installer productivity.
- Manual changeover from heat to cool eliminates unexpected system operation.
- °F or °C temperature display for added model flexibility.
- Selectable heating cycle rate (1, 3, 4, 5, 6 or 9, 12 cph) for a variety of applications which reduces the amount of inventory.
- Cooling cycle rate is fixed (3 cph), the standard setting for compressors, for speedy installation.
- Setpoints are permanently held in memory (no batteries used) and retained during power outages for increased installer and homeowner convenience.
- Power stealing and hard wired models available for virtually all equipment and application needs including gravity or radiating systems, hydronic heat, condensing gas furnaces, gas or oil forced air and electric heat.

### APPLICATION

The T8400C and T8401C Standard Electronic Thermostats provide single-stage, non-programmable temperature control for 24V heating-cooling systems with manual changeover from heat to cool.

The T8424C Electronic Multistage Thermostat provides two-stage heat and one-stage cool control.

The T8424D Electronic Multistage Thermostat provides two-stage heat and two-stage cool control.

### Contents

Application .....	1
Features .....	1
Specifications .....	2
Ordering Information .....	2
Installation .....	3
Settings and Adjustments .....	8
Operation .....	10
Checkout .....	12
Troubleshooting .....	13



## SPECIFICATIONS

### IMPORTANT

*The specifications given in this publication do not include normal manufacturing tolerances; therefore, an individual unit might not exactly match the listed specifications. Also, this product is tested and calibrated under closely controlled conditions, and some minor differences in performance can be expected if those conditions are changed.*

T8400C, T8401C, T8424C,D TRADELINE® models include a thermostat, wallplate for wiring and mounting thermostat and owner's guide.

T8400C, T8401C SUPER TRADELINE® models include a thermostat, wallplate (for mounting and wiring thermostat), two decorator cover plates for covering wall marks (3-7/8 in. x 3-7/8 in. and 5-3/4 in x 5-3/4 in.), and owner's guide.

### Power:

T8400C: 24 Vac nominal, 18 to 30 Vac, 50/60 Hz.  
 T8401C: 24 Vac nominal, 18 to 30 Vac, 50/60 Hz.  
 T8424C,D: 24 Vac nominal, 18 to 30 Vac, 50/60 Hz.

### Electrical Ratings:

Heating: .02 to 1.5A run; 3.5A inrush.  
 Cooling: .02 to 1.5A run; 7.5A inrush.  
 Fan: .02 to 0.5A run; 2.5A inrush.

### Current Draw:

T8400C Power Stealing Thermostat requires less than 0.25 mA current draw when the thermostat calls for heat and is compatible with most 24V microprocessor systems. The T8400C Power Stealing Thermostat can be used in any non-millivolt application where the T8401C and T8424C,D Hard Wired Thermostats cannot be used. For further detail, see Power Stealing in the Operation section.

### Temperature Adjustment:

Setpoint temperature is adjusted by using the ▲ or ▼ keys. One press changes the setpoint one degree; pressing and holding changes the setpoint several degrees.

**Temperature Setting Range:** 40°F (4°C) to 99°F (37°C).

**Ambient Temperature Range:** 40°F (4°C) to 110°F (43°C).

**Shipping Temperature Range:** -20°F (-29°C) to 120°F (49°C).

**Operating Relative Humidity:** 5% to 90% RH, non-condensing.

### Cycle Rates (at 50% Load):

Heating: Selectable at 1, 3, 4, 5, 6, 9 or 12 cph. See Table 1 for cycle rate options and corresponding system equipment.  
 Cooling: Fixed at 3 cph.

**Table 1. Heating Cycle Rates.**

System	Cycles Per Hour
Steam, gravity	1
Hydronic heat, condensing gas furnaces <sup>a</sup>	3
Special applications <sup>b</sup>	4, 5
Gas or oil forced air (default)	6
Electric heat	9
Special applications <sup>b</sup>	12

<sup>a</sup> High efficiency furnace.

<sup>b</sup> Refer to equipment manufacturer's instructions.

### Finish:

T8400C, T8401C and T8424C,D TRADELINE® AND SUPER TRADELINE®: Taupe finish.

T8400C, T8401C and T8424C,D STANDARD MODELS: Premier White® finish and only available in builder packs of 20.

**Accessory:** Decorator cover plates (for covering wall marks): 5-3/4 in. x 5-3/4 in. and 3-7/8 in. x 3-7/8 in.

**Dimensions:** See Fig. 1 or 2.

## ORDERING INFORMATION

When purchasing replacement and modernization products from your TRADELINE® wholesaler or distributor, refer to the TRADELINE® Catalog or price sheets for complete ordering number.

If you have additional questions, need further information, or would like to comment on our products or services, please write or phone:

1. Your local Home and Building Control Sales Office (check white pages of your phone directory).
2. Home and Building Control Customer Relations  
 Honeywell, 1985 Douglas Drive North  
 Golden Valley, Minnesota 55422 (800) 468-1502

In Canada—Honeywell Limited/Honeywell Limitée, 35 Dynamic Drive, Scarborough, Ontario M1V 4Z9.

International Sales and Service Offices in all principal cities of the world. Manufacturing in Australia, Canada, Finland, France, Germany, Japan, Mexico, Netherlands, Spain, Taiwan, United Kingdom, U.S.A.

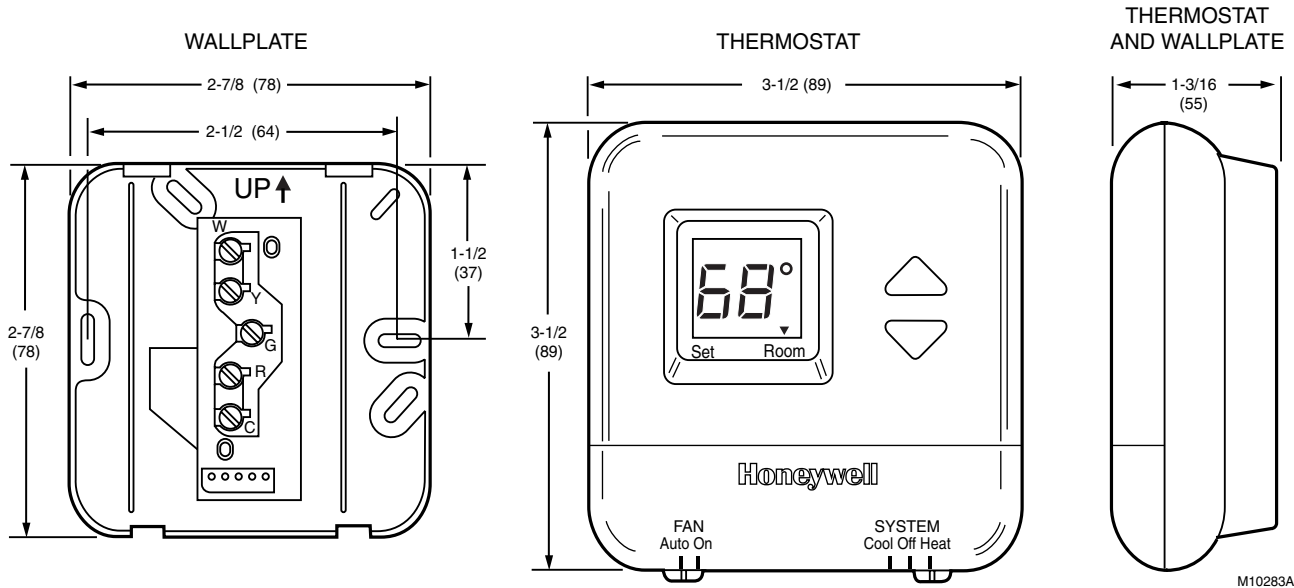

Fig. 1. T8400/T8401 Thermostat dimensions in in. (mm).

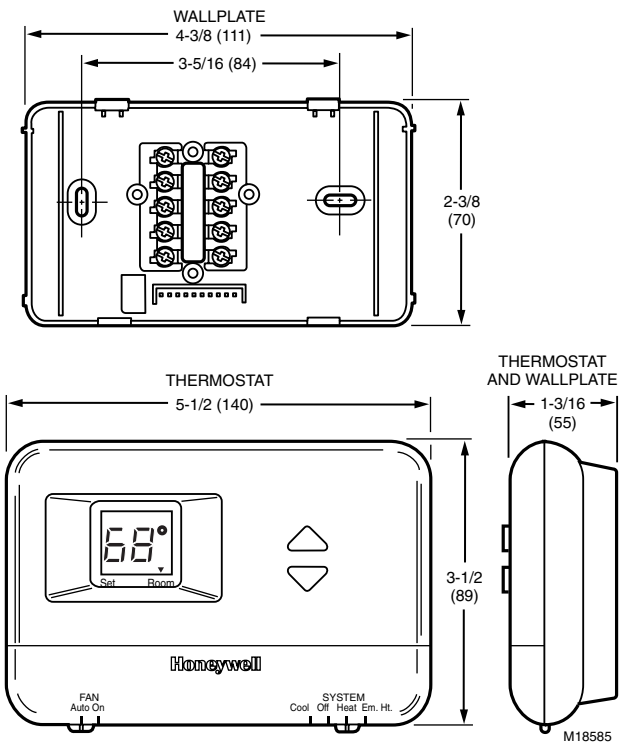

Fig. 2. T8424 Thermostat dimensions in in. (mm).

## INSTALLATION

### When Installing this Product...

1. Read these instructions carefully. Failure to follow them could damage the product or cause a hazardous condition.
2. Check the ratings given in the instructions and on the product to make sure the product is suitable for your application.
3. Installer must be a trained, experienced service technician.
4. After installation is complete, check out product operation as provided in these instructions.



### CAUTION

Disconnect power supply before beginning wiring to prevent electrical shock or equipment damage.



### MERCURY NOTICE

If this control is replacing a control that contains mercury in a sealed tube, do not place your old control in the trash. Dispose of it properly.

Contact your local waste management authority for instructions regarding recycling and the proper disposal of the control. If you have questions, call the Honeywell Customer Response Center at 1-800-468-1502.

## Location

Install the thermostat about 5 ft (1.5 m) above the floor in an area with good air circulation at average temperature. See Fig. 3. Do not install the thermostat where it can be affected by:

— drafts or dead spots behind doors and in corners.

- hot or cold air from ducts.
- radiant heat from the sun or appliances.
- concealed pipes and chimneys.
- unheated (uncooled) areas such as an outside wall behind the thermostat.

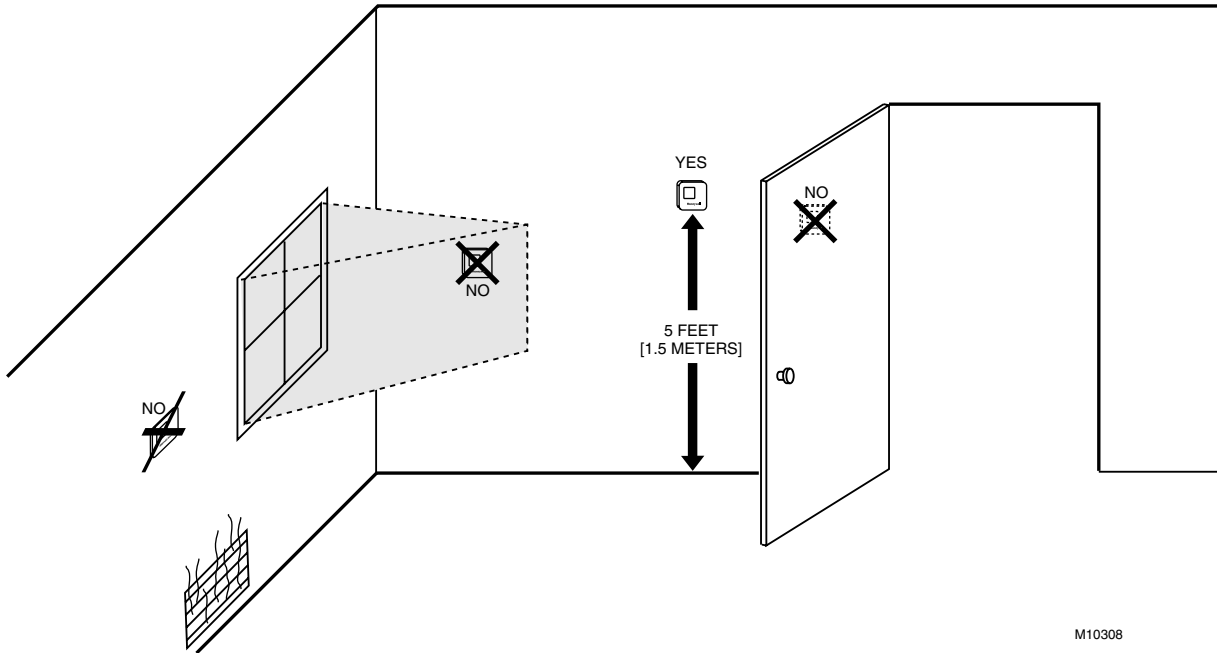

M10308

Fig. 3. Typical location of thermostat.

## Mounting Decorator Cover Plate and Wallplate to Wall

### IMPORTANT

*Level for appearance only. The thermostat functions normally even when not mounted level.*

NOTE: The TRADELINE® models include a thermostat and wallplate (for wiring and mounting thermostat). T8400C, T8401C SUPER TRADELINE® models include a thermostat, wallplate (for wiring and mounting thermostat) and two decorator cover plates (for covering wall marks).

Mount decorator cover plate (SUPER TRADELINE® model only), wallplate, T8400C, T8401C or T8424C,D, and the screws provided (see Fig. 4 or 5) as follows:

1. Place the desired decorator cover plate and the wallplate at the desired location on the wall.
2. Pull the thermostat wire through the entrance hole on the decorator cover plate, then through the wallplate entrance hole.
3. Select the two mounting holes that best fit the application.
4. Fasten the decorator cover plate and the wallplate to the wall using the screws provided.
5. After wiring the wallplate, plug the hole to prevent drafts from affecting the thermostat; see Wiring section.

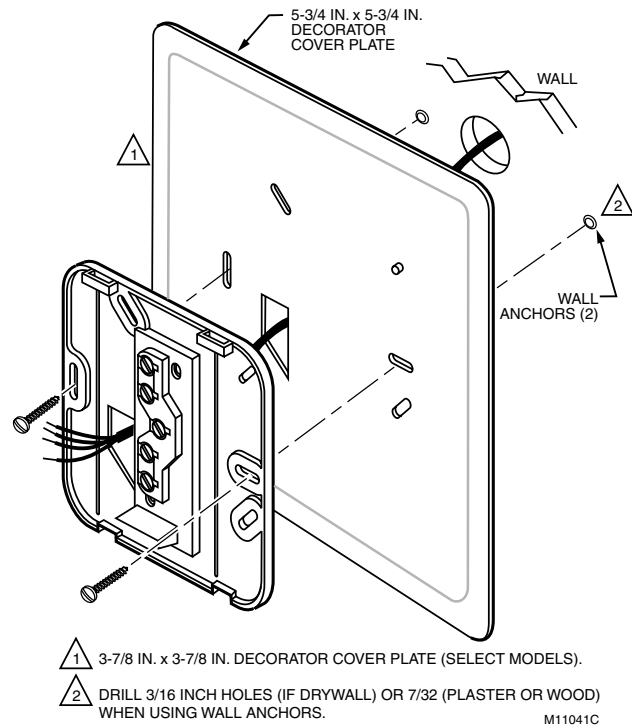

1 3-7/8 IN. x 3-7/8 IN. DECORATOR COVER PLATE (SELECT MODELS).

2 DRILL 3/16 INCH HOLES (IF DRYWALL) OR 7/32 (PLASTER OR WOOD) WHEN USING WALL ANCHORS.

M11041C

Fig. 4. Mounting the T8400 and T8401 decorator cover plate and wallplate to wall.

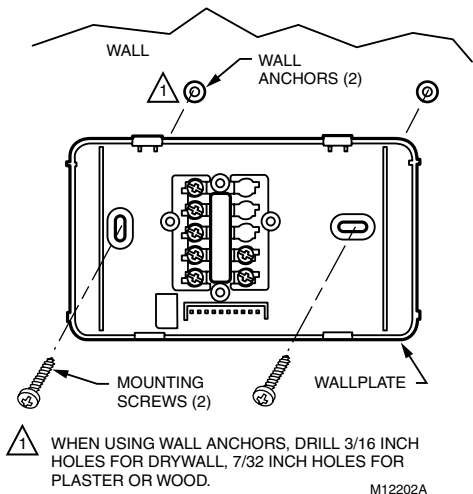

Fig. 5. Mounting the T8424 wallplate to wall.

## Wiring

### IMPORTANT

Use an 18-gauge maximum wire for wiring the thermostats.

All wiring must comply with local electrical codes and ordinances. Disconnect the power supply to prevent electrical shock or equipment damage.

NOTE: To ensure proper mounting of thermostat, restrict all wiring to the shaded area on the left side of the terminals. See Fig. 6 or 7.

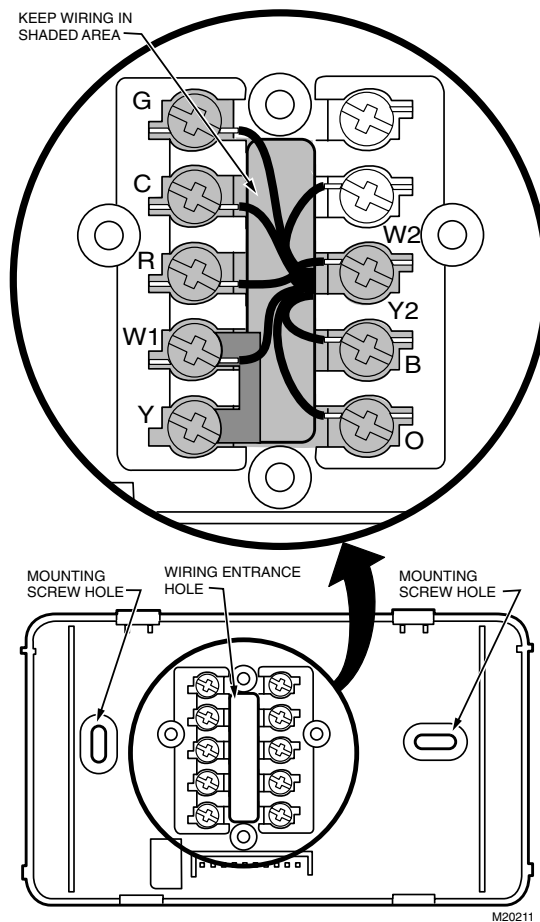

Fig. 7. Restrict T8424 wiring to shaded area.

The shape of the terminals permits insertion of straight or wraparound wiring connections; either method is acceptable. See Fig. 8 or 9.

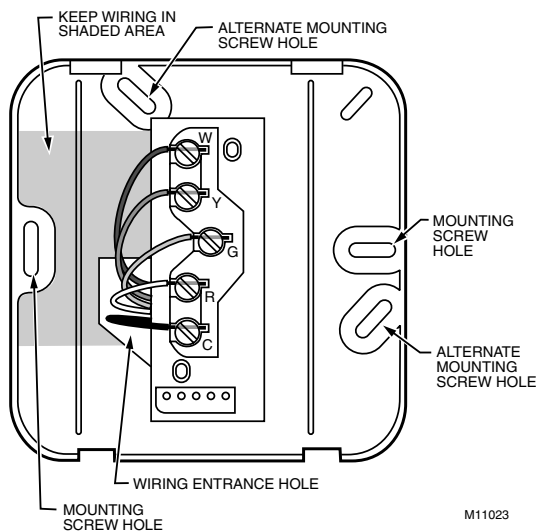

Fig. 6. Restrict T8400 and T8401 wiring to shaded area.

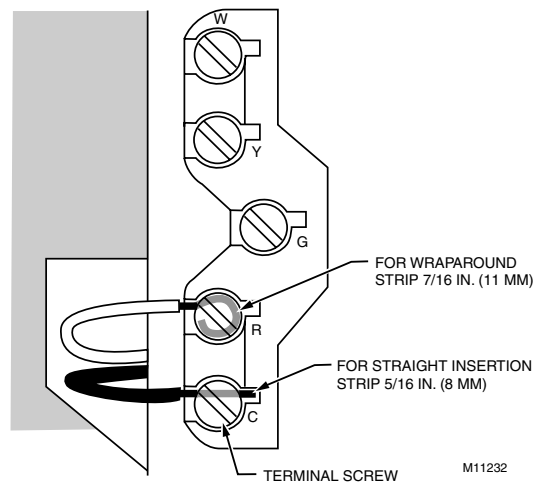

Fig. 8. T8400 and T8401 wiring connections.

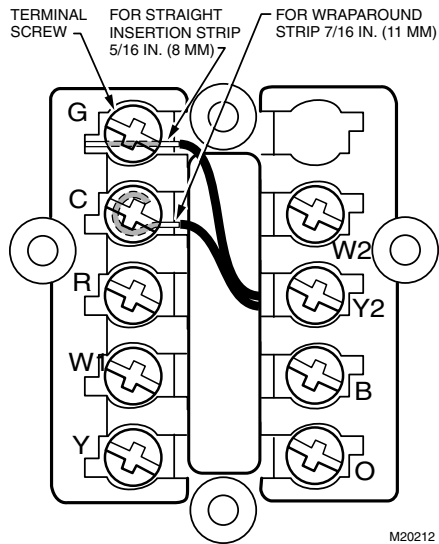

Fig. 9. T8424 wiring connections.

The T8400C Thermostats steal power through the heating and cooling system controls and are adaptable to most 4-wire, 18 to 30 Vac heating-cooling systems.

The T8401C and T8424C,D Thermostats are powered directly from the system transformer and are adaptable to most 5-wire, 18 to 30 Vac heating-cooling systems. Refer to Fig. 10 through 14 for typical wiring hookups.

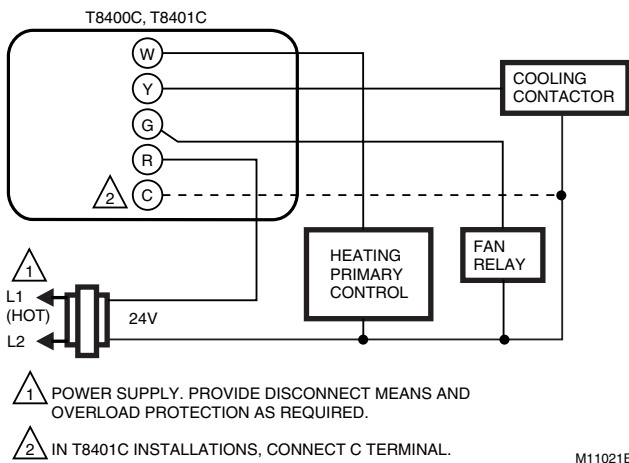

Fig. 10. T8400C/T8401C heat-cool wiring diagram in single transformer system with gas heat/electric cooling.

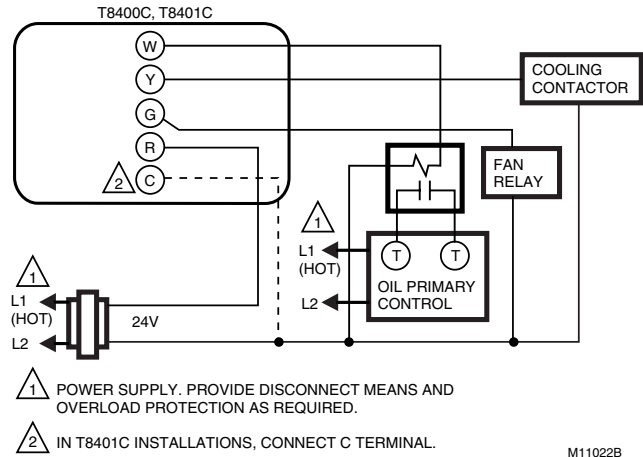

Fig. 11. T8400C/T8401C heat-cool wiring diagram in oil heating/electric cooling system. Oil primary has its own transformer.

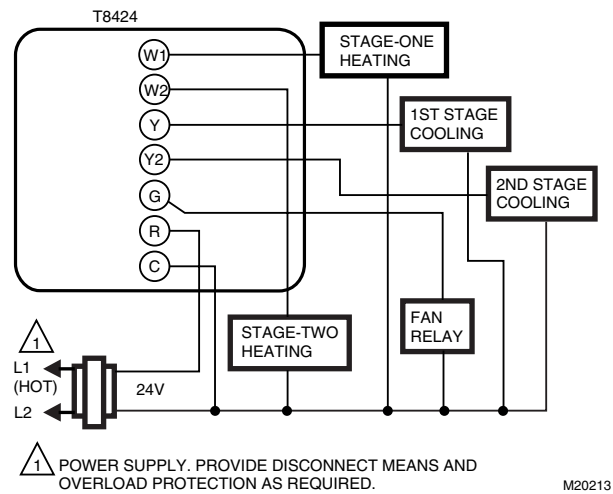
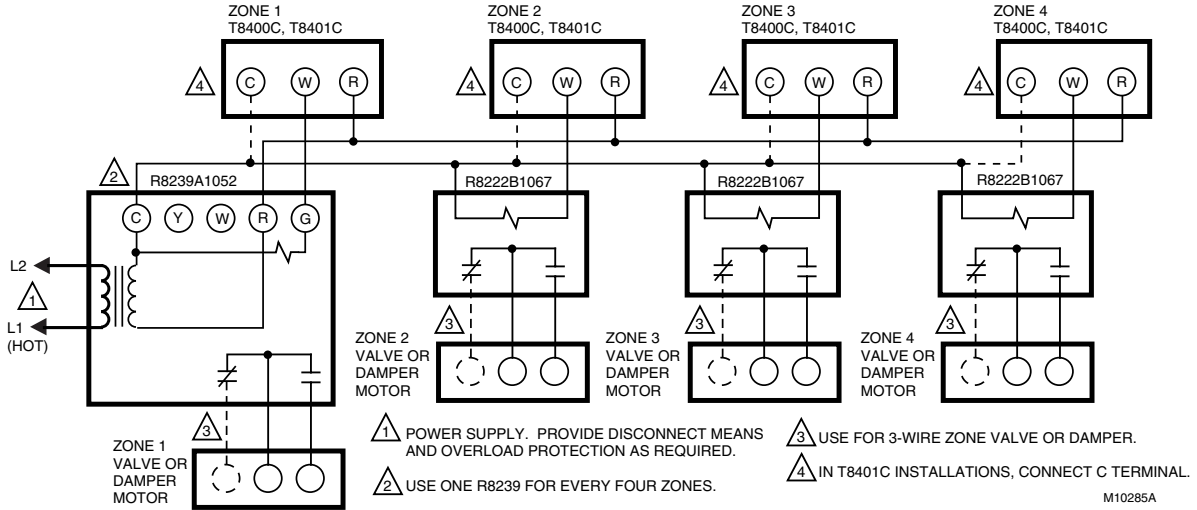
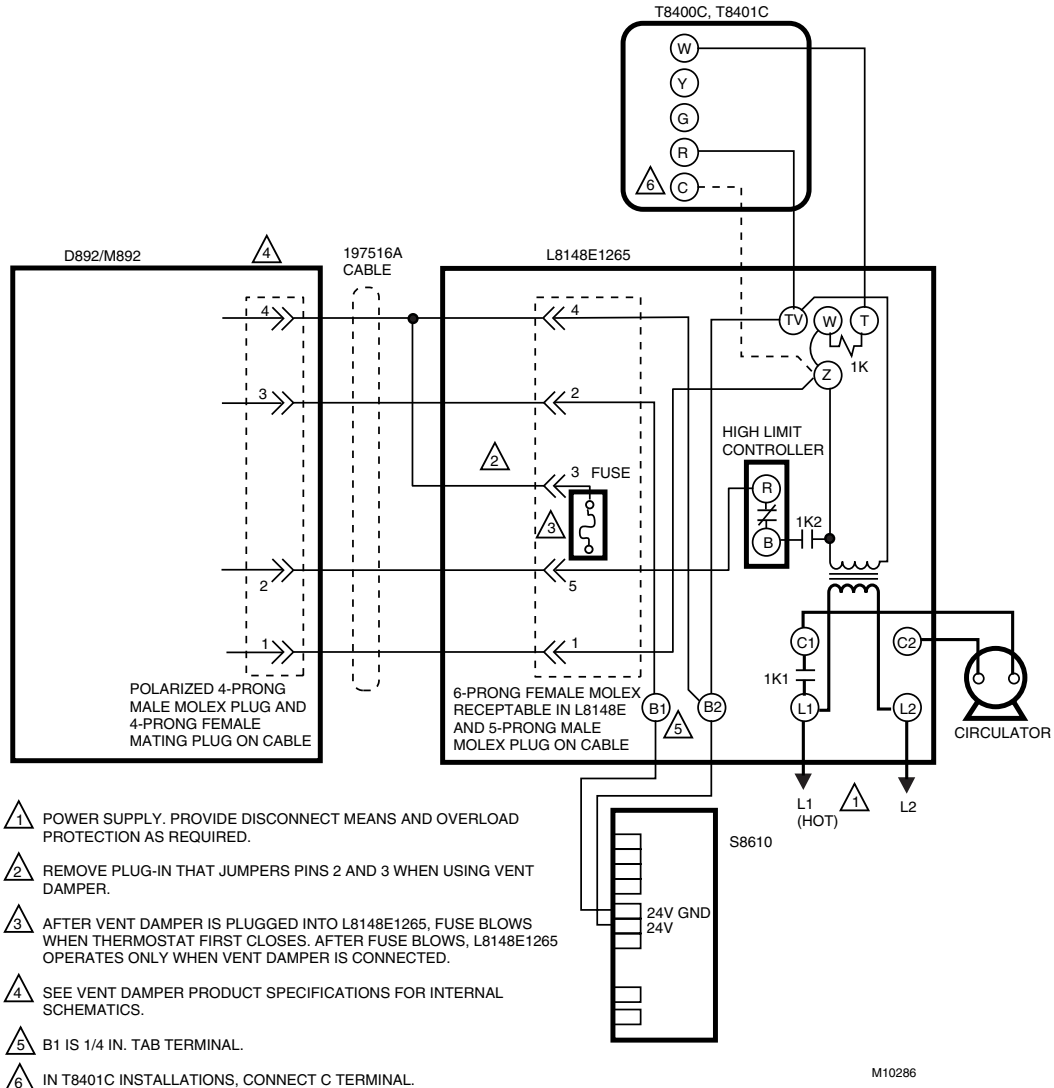

Fig. 12. T8424C,D two-stage heat and two-stage cool system with manual changeover wiring diagram.



**Fig. 13. T8400C/T8401C heat only wiring diagram for controlling incompatible or 3-wire zone valves or dampers. Heating equipment is operated by end switch on the zone valve or motor, or by thermostat in master zone.**



**Fig. 14. T8400C/T8401C heat only wiring diagram with L8148E1265 (with internal plug) wired directly to vent damper in hydronic intermittent pilot system.**

## Mounting Thermostat to Wallplate

1. Engage the tabs at the top of the thermostat and wallplate.
2. Swing down the thermostat and press the lower edge of the thermostat onto the wallplate to latch. See Fig. 10.

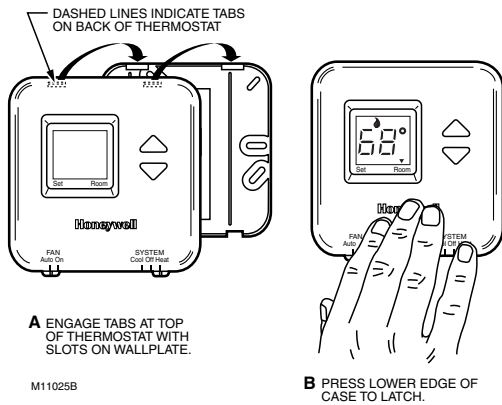

Fig. 15. Mounting T8400 or T8401 thermostat to wallplate.

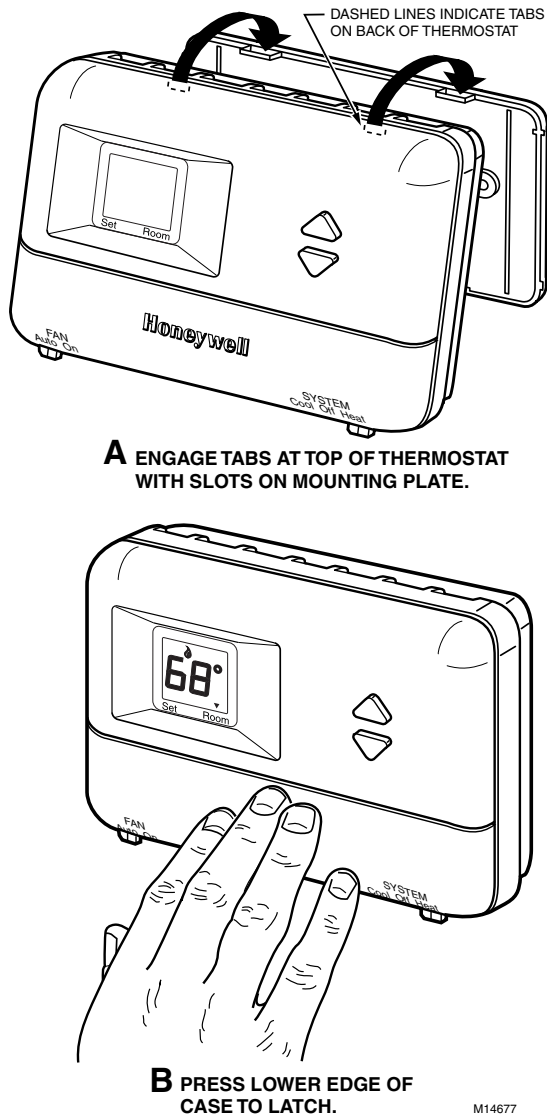

Fig. 16. Mounting T8424 thermostat to wallplate.

## SETTINGS AND ADJUSTMENTS

### Setting Fan and System Switches

Fan and system settings are controlled manually using the switches located at the bottom of the thermostat case. See Fig. 17 or 18.

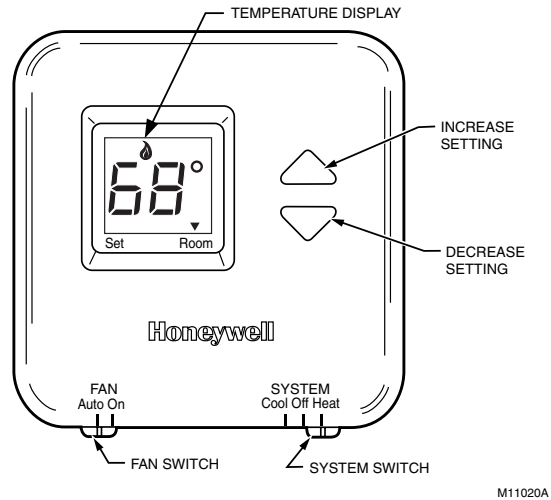

Fig. 17. T8400 and T8401 temperature display and system switches.

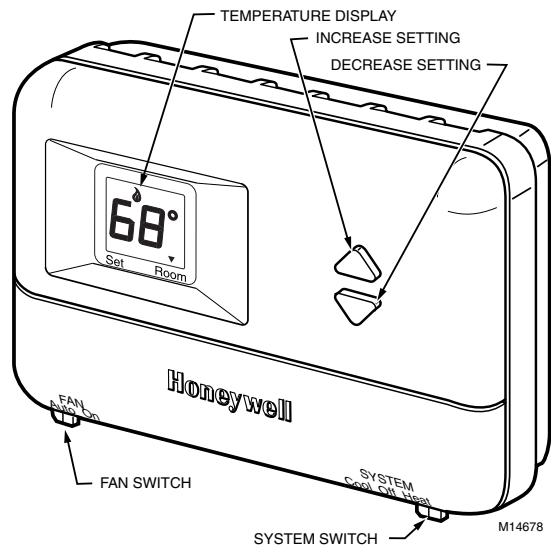

Fig. 18. T8424 temperature display and system switches.

### Fan Switch

Fan switch settings are:

- ON: The fan runs continuously. Use for improved air circulation.
- AUTO: Normal setting for most homes. In cooling, the fan starts and stops with the cooling equipment. In heating, the fan is controlled directly by the heating equipment and may start a few minutes after the heating equipment turns on (on



most systems). When using an electric heat thermostat, the fan starts and stops with the heating equipment.

Slide the switch in the bottom left corner of the thermostat to select the desired fan setting.

### System Switch

System switch settings control thermostat operation as follows:

- COOL: The thermostat controls the cooling system.
- HEAT: The thermostat controls the heating system.
- OFF: Both heating and cooling are off.

Slide the switch in the bottom right corner of the thermostat to select the desired system setting.

### Set Temperature Setpoint

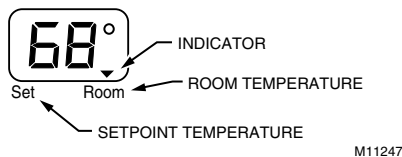

NOTE: Temperature setpoint range is 40° to 99°F (4° to 37°C).

The temperature setpoint and the room temperature are shown separately on the display. The ▼ indicator points to **Set** when the temperature setpoint is displayed and to **Room** when the room temperature is displayed.



M11247

To set the temperature setpoint:

1. Select Heat or Cool by sliding the system switch in the lower right corner of the thermostat to the desired mode. See Fig. 17 or 18.
2. To display the selected temperature setpoint on the digital display, press either the ▲ or ▼ key once. The temperature setpoint is displayed for approximately five seconds as the indicator points to Set and flashes.  M14680
3. To increase the temperature setpoint press the ▲ key. Each press changes the setpoint one degree; press and hold to change the setpoint several degrees.  M14681
4. To decrease the setpoint temperature press the ▼ key. Each press changes the setpoint one degree; press and hold to change the setpoint several degrees.  M14682

### Setting °F/°C Indication and Heat Cycle Rate

NOTE: To save changes to the °F/°C indication and the heat cycle rate, all seven steps must be completed.

To set the °F/°C indication and heat cycle rate:

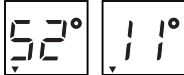
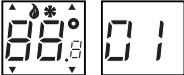
1. If the room temperature is displayed in °F, set the temperature setpoint to 52°F. If the room temperature is displayed in °C, set the temperature setpoint to 11°C.  M14683
2. Press the ▲ and ▼ keys simultaneously for more than one second to light all segments on display and to enter installer setup mode. When the keys are released, a two-digit software code is displayed.  M14684



#### Optional System Checkout

When in steps B and C only, the ▼ key can be used to turn heat or cool outputs on and off. Change the system switch setting to test heat or cool outputs. No action takes place if the system is in the Off position.

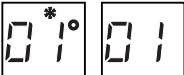



#### EXAMPLES:

- System setting at HEAT: If heat is on, the ▼ key turns it off; if heat is off, ▼ turns it on.  M14684
- System setting at COOL: If cool is on, ▼ key turns it off; if cool is off, ▼ turns it on.  M14685

NOTE: In installer setup mode only, each press of the ▲ key momentarily displays 01 and each press of the ▼ key momentarily displays 02. When the keys are released, these two-digit codes are no longer displayed.

3. Press the ▲ key. Factory information is displayed. A typical example is shown, but information displayed varies by model. This information is for factory use only.  M14687
4. Press the ▲ key again to display °C or °F.  M14688
5. Press the ▼ key to change the °C or °F indication.  M14689

NOTE: Steps 6 through 9 apply only to T8424 Thermostats.

6. Press ▲ key to display number of cooling stages.  M20208
7. Press ▼ key to change the number of cooling stages.  M20207
8. Press ▲ key to display the number of heating stages.  M20209
9. Press ▼ key to change the number of heating stages.  M20210

10. Press the ▲ key to display the heat cycle rate of 1, 3, 4, 5, 6, 9 or 12. When set at two stages of heat (T8024 only), both stages operate at selected cycle rate. If the desired cycle is displayed, press the ▲ key to exit the installer setup mode. To change the heat cycle rate, press the ▼ key to scroll between cycle rates. Stop scrolling when the desired rate is displayed. See Table 2 for the cycle rate options and the corresponding system equipment.



**Table 2. Heating Cycle Rates.**

System	Cycles Per Hour
Steam, gravity	1
Hydronic heat, condensing gas furnaces <sup>a</sup>	3
Special applications <sup>b</sup>	4, 5
Gas or oil forced air (default)	6
Electric heat	9
Special applications <sup>b</sup>	12

<sup>a</sup> High efficiency furnace.

<sup>b</sup> Refer to equipment manufacturer's instructions.

11. Press the ▲ key to display algorithm configuration.
12. Press the ▲ key again to change the algorithm to C1 or C3.
- C1 = standard algorithm.  
C3 = aggressive algorithm (can cause overshooting).
13. Press the ▲ key again. Current algorithm (CC) is displayed. A typical example is shown, but CC varies by model. This information is for factory use only.
14. Press the ▲ key to save all changes, exit installer setup mode and return to normal operation.



NOTE: After exiting installer setup mode, change the setpoint to the desired room temperature.

## OPERATION

The T8400C and T8401C Standard Electronic Thermostats provide single-stage temperature control using proportional plus integral (P+I) control to eliminate droop. The T8424C provides two-stage heat and two-stage cool temperature control with P+I control. The T8424D Electronic Multistage Thermostat provides two-stage heat and two-stage cool temperature control and also uses P+I control.

## Zero Droop Performance

The thermostats control temperature closer to setpoint than electromechanical thermostats. This is because proportional plus integral control maintains the same indoor temperature independent of the outdoor temperature. Thus the T8400C and T8401C Thermostats provide tight temperature control with virtually no noticeable swings in temperature setpoint, a condition referred to as droop. This zero droop performance provides improved occupancy comfort. Occupants do not need to continually adjust thermostat settings to be comfortable, even during severe weather. Electromechanical thermostats have little control over droop, thus resulting in room temperature changes of 3°F to 5°F as outdoor temperature varies.

## Power Stealing

Unlike hard wired thermostats which are powered directly from the system transformer, the T8400C Thermostat steals power through the heating and cooling system controls and can be used in applications where existing wiring does not permit using hard wired thermostats. See Fig. 19 and 20.

Previous Honeywell power stealing thermostats required 80 mA of load current when the heating and cooling was on. The T8400C Thermostat requires only 2.5 mA of load current (1/32 of previous models) when the heating or cooling is on. When the heating or cooling is off, the thermostat operates at 0.1 mA (1/100 of previous models). Other Honeywell power stealing thermostats are available, but they have different powering requirements than the T8400C. This low current draw makes the T8400C applicable to most 24V heating and cooling systems.

The T8400C, T8401C and T8424C,D Thermostats only operate when mounted on the wallplate with 24V applied. Batteries are not required for operation because temperature setpoints and configuration settings are retained permanently in memory.