



SEL-787 Transformer Protection Relay



Major Features and Benefits

The SEL-787 Transformer Protection Relay provides unsurpassed protection, integration, and control features in a flexible, compact, and cost-effective package.

- **Standard Protection Features.** Two-winding dual-slope differential protection with harmonic blocking and restraint, and phase, negative-sequence, residual-ground, and neutral-ground overcurrent elements provide backup protection. Breaker failure protection is included for two three-pole breakers.
- **Optional Protection Features.** Use the SEL-787 with optional voltage inputs to provide volts/hertz protection with frequency tracking from 20 to 70 Hz for generator step-up and other variable frequency applications. Implement load shedding and other control schemes with over- and underfrequency and over- and undervoltage elements. In addition, use Sensitive Restricted Earth Fault (REF) protection for grounded-wye transformers.
- **Transformer Monitoring.** Use transformer through-fault monitoring to measure accumulated through-fault levels of the transformer. Monitor ambient, load tap-changer (LTC), tank, and transformer oil temperature through the use of optional 4–20 mA or RTD thermal inputs.
- **Operator Controls.** Four programmable front-panel pushbuttons each with two programmable LEDs allow for a wide variety of uses including easy trip and close control and status indications for a breaker. Implement local and remote operator control schemes through use of 32 local and 32 remote control bits.
- **Relay and Logic Settings Software.** ACSELERATOR QuickSet[®] SEL-5030 Software reduces engineering costs for relay settings and logic programming. Tools in ACSELERATOR QuickSet make it easy to develop SELOGIC[®] control equations. Use the built-in phasor display to verify proper CT polarity and phasing.
- **Metering and Reporting.** Built-in metering functions eliminate separately mounted metering devices. Analyze Sequential Events Recorder (SER) reports and oscillographic event reports for rapid commissioning, testing, and post-fault diagnostics. Unsolicited SER protocol allows station-wide collection of binary SER messages.
- **Additional Standard Features.** Includes Modbus[®] RTU, Event Messenger support, MIRRORING BITS[®] communications, load profile, support for 12 external RTDs (SEL-2600 series module), IRIG-B input, advanced SELOGIC, configurable labels, IEEE C37.118-compliant synchrophasor protocol, and SEL-2812 compatible ST[®] connectors fiber-optic serial port.
- **Optional Features.** Select from a wide offering of optional features, including IEC 61850, Modbus TCP/IP, Simple Network Time Protocol (SNTP), DNP3 LAN/WAN, DNP3 Serial, 10 internal RTDs, expanded digital/analog I/O, voltage inputs, additional EIA-232 or EIA-485 communications ports, and single or dual copper wire or fiber-optic Ethernet ports.

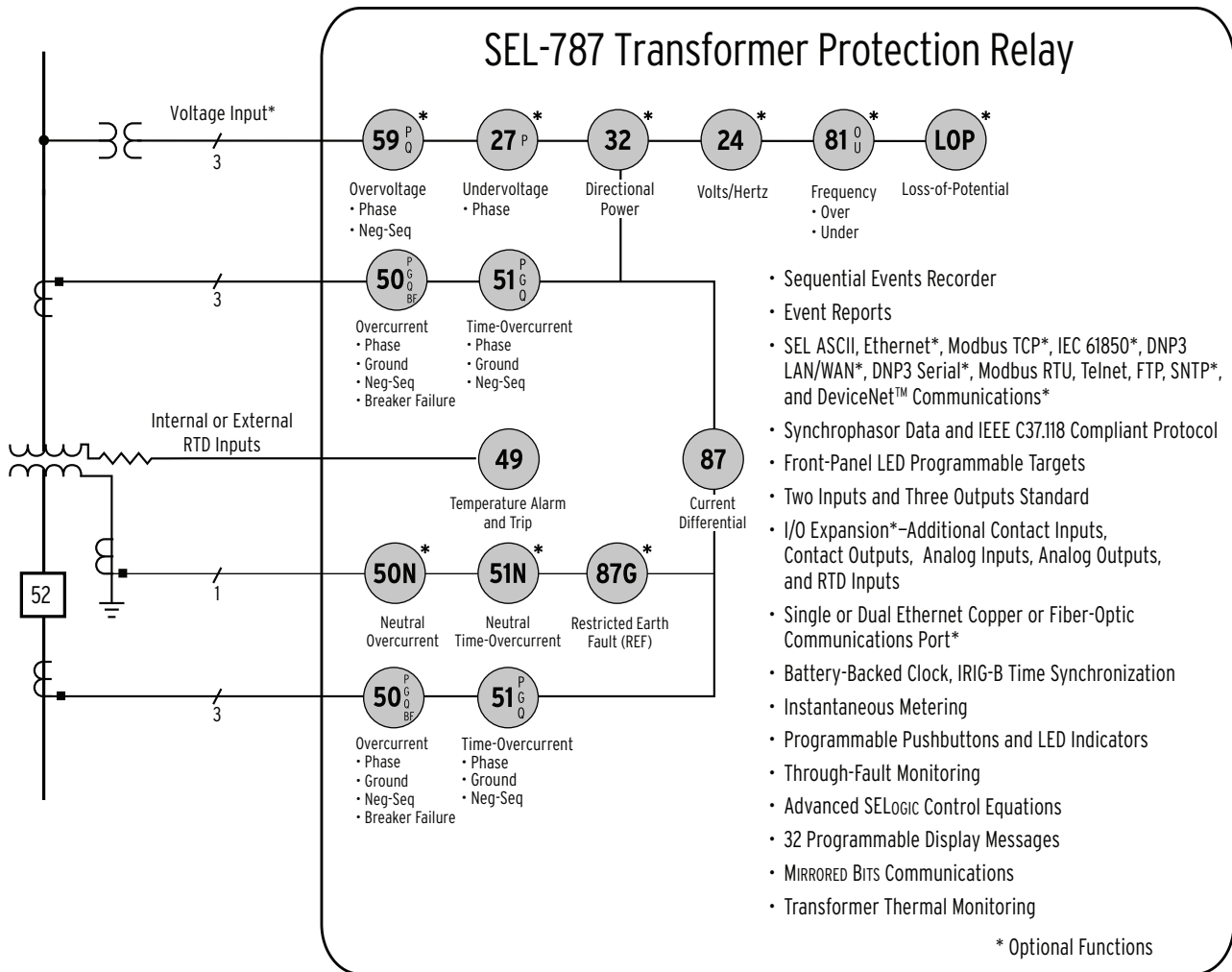

Figure 1 Functional Diagram

Protection Features

The SEL-787 provides the same dual-slope differential characteristic used in the popular SEL-387 and SEL-587 series of transformer differential relays. The SEL-787 includes a complete set of phase, negative-sequence, and residual overcurrent elements for each winding, as well as REF and neutral-overcurrent elements for grounded wye transformers.

Use as many as 12 independent RTD driven thermal elements with trip and alarm levels to monitor ambient and equipment temperatures throughout the substation.

For the optional volts/hertz element, you can add three-phase voltage inputs that give the SEL-787 volts/hertz protection with definite and time-delay characteristics, along with directional power, over- and underfrequency and voltage elements with two independent pickup levels.

Transformer Differential

The SEL-787 has three restrained differential elements (87R). These elements use operate and restraint quantities calculated from the winding input currents. Set the differential elements with either single- or dual-slope percentage differential characteristics. *Figure 2* illustrates a dual-slope setting. The percent-slope characteristic helps prevent unwanted relay operation because of possible unbalance between CTs during external faults. CT unbalance can result from tap changing in the power transformer and error difference between the CTs on either side of a power transformer.

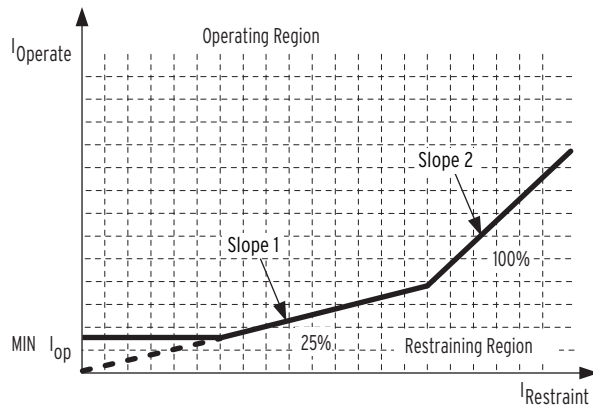

Figure 2 Dual-Slope Restrained Differential Characteristic

The relay allows you to choose harmonic blocking, harmonic restraint, or both, providing a reliable differential protection during transformer inrush conditions. Even-numbered harmonics (second and fourth) provide security during energization, while fifth-harmonic blocking provides security for overexcitation conditions. Set second-, fourth-, and fifth-harmonic thresholds independently.

An additional alarm function for the fifth-harmonic current employs a separate threshold and an adjustable timer to warn of overexcitation. This may be useful for transformer applications in or near generating stations. A set of unrestrained differential current elements simply compares the differential operating current quantity to a setting value, typically about 10 times the TAP setting. This pickup setting is only exceeded for internal faults.

The three independent unrestrained differential elements (87U) provide rapid assertion without delay when differential operate current levels exceed the 87U pickup threshold that is set depending on the application. Typical 87U pickup level settings are between 8 and 10 per unit of operate current.

Restricted Earth Fault (REF) Protection

Apply the REF protection feature to provide sensitive detection of internal ground faults on grounded wye-connected transformer windings and autotransformers. Order the SEL-787 with the Slot E card containing the 1 A or 5 A current input for REF protection. The single-phase 1 A or 5 A CT provided as a Slot E ordering option is used for introduction of neutral CT operating current. Polarizing current is derived from the residual current calculated for the protected winding (Winding 1, Winding 2, or both windings). A sensitive directional element determines whether the fault is internal or external. Zero-sequence current thresholds and selectable CT saturation logic supervise tripping.

Overcurrent Protection

The SEL-787 provides complete overcurrent protection for a two-winding transformer. Phase overcurrent protection is provided for both three-phase winding inputs. The following overcurrent elements are provided.

Instantaneous Overcurrent Elements

The following instantaneous overcurrent elements are provided in the SEL-787 base configuration. All instantaneous overcurrent elements provide torque control.

- Four instantaneous phase overcurrent (50P) elements for Windings 1 and 2 (eight total). These phase elements operate on the maximum of the phase currents. Level 1 phase overcurrent elements also include per-phase elements. Peak detection algorithms are used to enhance element sensitivity during high fault current conditions, where severe CT saturation may occur.
- Two instantaneous negative-sequence overcurrent (50Q) elements for Windings 1 and 2 (four total). These phase elements operate on negative-sequence content for each three-phase winding.
- Two residual overcurrent (50G) elements for windings 1 and 2 (four total). These elements use calculated residual (3I0) current levels from each winding for ground fault detection.

When ordered with the optional current channel in Slot E, the SEL-787 also provides two instantaneous neutral-overcurrent elements (50N) with two levels of neutral-overcurrent detection.

Time-Overcurrent Elements

The SEL-787 base configuration provides the following time-overcurrent elements. The time-overcurrent elements support the IEC and US (IEEE) time-overcurrent characteristics shown in *Table 1*. Electromechanical disc reset capabilities are provided for all time-overcurrent elements.

- Eight phase time-overcurrent (51P) elements are provided. These phase elements operate on the individual phases as well as the maximum of the phase currents for each winding.
- Two negative-sequence time-overcurrent (51Q) elements are provided. These elements operate on the calculated negative-sequence current for each set of three-phase winding inputs of the transformer.
- Two residual overcurrent (51G) elements are provided. These elements use calculated residual (3I0) current levels from each winding for ground fault detection.

When ordered with the optional current channel in Slot E, the SEL-787 also provides one neutral time-overcurrent element (51N).

Table 1 Time-Overcurrent Curves

US (IEEE)	IEC
Moderately Inverse	Standard Inverse
Inverse	Very Inverse
Very Inverse	Extremely Inverse
Extremely Inverse	Long-Time Inverse
Short-Time Inverse	Short-Time Inverse

Breaker Failure Protection

The SEL-787 offers breaker failure protection for two three-pole breakers. Use the breaker failure detection to issue re-trip commands to the failed breaker, or to trip adjacent breakers using the relay's contact output logic or communications-based tripping schemes.

Breaker failure is initiated by the breaker failure initiate (BFI) SELOGIC input (see *Figure 3*). The BFI input is typically driven by local and remote open/trip commands to the breaker. Once the BFI input is received, the breaker failure element monitors positive- and negative-sequence current magnitudes and the breaker auxiliary contacts to determine when to initiate the breaker failure delay timer. If current or breaker auxiliary contact status does not indicate an open breaker condition within the time set by the breaker failure delay timer, the element issues a breaker failure trip output.

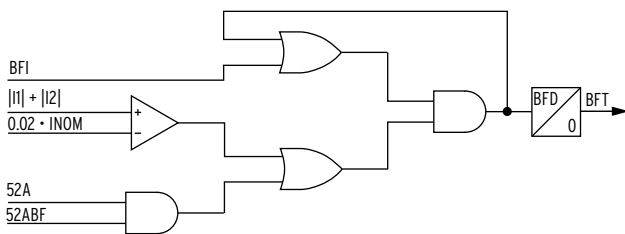
**Figure 3 Breaker Failure Protection**

Volts/Hertz Protection

Overexcitation occurs when the magnetic core of a power apparatus becomes saturated. When saturation occurs stray flux is induced in nonlaminated components, which can result in overheating. By ordering the voltage option to the SEL-787, you can add a volts/hertz element to detect overexcitation. An SEL-787 with optional voltage inputs provides a sensitive definite-time delayed element, plus a tripping element with a composite operating time.

For example, the relay calculates the present transformer volts/hertz as a percentage of nominal, based on present measured values and the nominal voltage and frequency settings. The relay starts a timer when the system voltage causes an excursion that exceeds the volts/hertz overexcitation setting. If the condition remains for the set

time delay, the relay asserts and typically provides an alarm function. The element is supervised by a SELOGIC torque control equation, which enables or disables the element as required by the application.

Use the SEL-5806 Volts/Hertz User Curve Design Software to set the user-defined curve (see *Figure 4*). For tripping, the relay provides a time integrating element with a settable operating characteristic. You can set the relay element to operate as an inverse-time element, a user-defined curve element, a composite element with an inverse-time characteristic and a definite-time characteristic, or a dual-level, definite-time element.

For any of these operating characteristics, the element provides a linear reset characteristic with a settable reset time. The torque-control setting also supervises this element. The tripping element has a percent-travel operating characteristic similar to that used by an induction-disc, time-overcurrent element. This characteristic emulates the heating effect of overexcitation on transformer components.

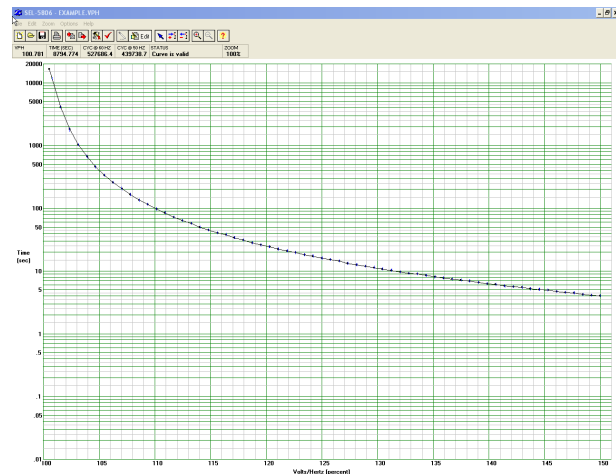
**Figure 4 SEL-5806 Volts/Hertz User Curve Design Example**

Over- and Undervoltage Protection

Phase undervoltage, overvoltage, and sequence overvoltage elements help you create protection and control schemes, such as undervoltage load shedding, or standby generation start/stop commands.

- ▶ Phase undervoltage elements operate with the minimum of the measured phase voltage magnitudes; these elements operate when any single-phase measurement falls below the set threshold.
- ▶ Phase overvoltage elements operate with the maximum of the measured phase voltage magnitudes.
- ▶ The negative-sequence overvoltage elements operate when respective measurements exceed set thresholds.

All voltage elements provide two pickup levels with definite-time delay settings.

Loss-of-Potential Detection

The SEL-787 with optional voltage inputs contains loss-of-potential (LOP) detection logic on the three-phase voltage input to the relay. The LOP logic detects open voltage transformer fuses or other conditions that cause a loss of relay secondary voltage input. The SEL-787 with optional voltage inputs includes LOP logic that detects one, two, or three open potential fuses. This patented LOP logic is unique, as it does not require settings and is universally applicable. The LOP feature allows for the blocking of protection elements to add security during fuse failure.

Over- and Underfrequency Protection

The SEL-787 with optional voltage inputs provides four over- and underfrequency elements. Each element operates as either an over- or underfrequency element with or without time delay, depending on the element pickup setting.

If the element pickup setting is less than the nominal system frequency setting, the element operates as an underfrequency element, picking up if the measured frequency is less than the set point. If the pickup setting exceeds the nominal system frequency, the element operates as an overfrequency element, picking up if the measured frequency exceeds the set point.

The SEL-787 with optional voltage inputs uses the positive sequence voltage to determine system frequency. All frequency elements are disabled if the positive sequence voltage is less than the minimum voltage threshold.

Directional Power Element Protection

The SEL-787 with optional voltage inputs provides two directional power elements for detecting real (watts) or reactive (VARs) directional power flow levels for the transformer winding associated with the three-phase voltage input. Each directional power element has a definite-time delay setting.

RTD Thermal Protection

When the SEL-787 is equipped with either the optional 10 RTD input expansion card or an external SEL-2600 RTD module with as many as 12 RTD inputs, as many as 12 thermal elements in the relay can be programmed for two levels of thermal protection per element. Each RTD input provides an alarm and trip thermal pickup setting in degrees C or F, provides open and shorted RTD detection, and is compatible with the following three-wire RTD types:

- PT100 (100 Ω platinum)
- NI100 (100 Ω nickel)
- NI120 (120 Ω nickel)
- CU10 (10 Ω copper)

Operator Controls

Operator Controls Eliminate Traditional Panel Control Switches

Four conveniently sized operator controls are located on the relay front panel (see *Figure 5*). The SER can be set to track operator controls. Change operator control functions by using SELOGIC control equations.

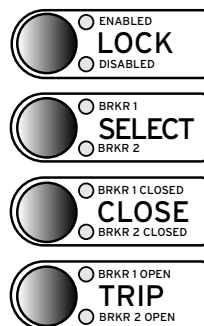

Figure 5 Operator Controls (Standard Model)

All text can be changed with the configurable labels.

The following operator control descriptions are for factory-set logic.

Lock: The **LOCK** operator control blocks selected functions. Press it for at least three seconds to engage or disengage the lock function. While locked in position, the following operator controls cannot change state if pressed: **TRIP** and **CLOSE**.

Select: The **SELECT** operator control selects the control of Breaker 1 or Breaker 2. The indicating LED for the pushbutton indicates the selected breaker. The selected breaker can then be controlled using the **CLOSE** and **TRIP** pushbuttons.

Close and Trip: Use the **CLOSE** and **TRIP** operator controls to close and open the connected circuit breaker. They can be programmed with intentional time delays to support operational requirements for breaker-mounted relays. This allows the operator to press the **CLOSE** or **TRIP** pushbutton, then move to an alternate location before the breaker command is executed.

SEL-787 Application

The SEL-787 is designed to provide differential and overcurrent protection for two-winding power transformers, generator step-up transformers and autotransformers. In addition, the SEL-787 contains advanced integration and control features that will allow its application in a wide variety of automation and control schemes.

Use the optional Slot E single-phase CT channel along with the RTD thermal elements to provide fan bank control and protection as shown in *Figure 6*. Use additional RTD thermal elements to monitor load tap-changer (LTC) tank temperatures and SELOGIC programming to indicate temperature differential alarms between transformer and LTC tank temperatures.

Apply the transformer through-fault monitoring of the SEL-787 to keep track of accumulated through-fault I^2t values. Monitor the number of through-faults, accumulated I^2t , and fault duration times to determine the frequency (through-fault events per day, week, month, or year) and impact of external faults on the transformer.

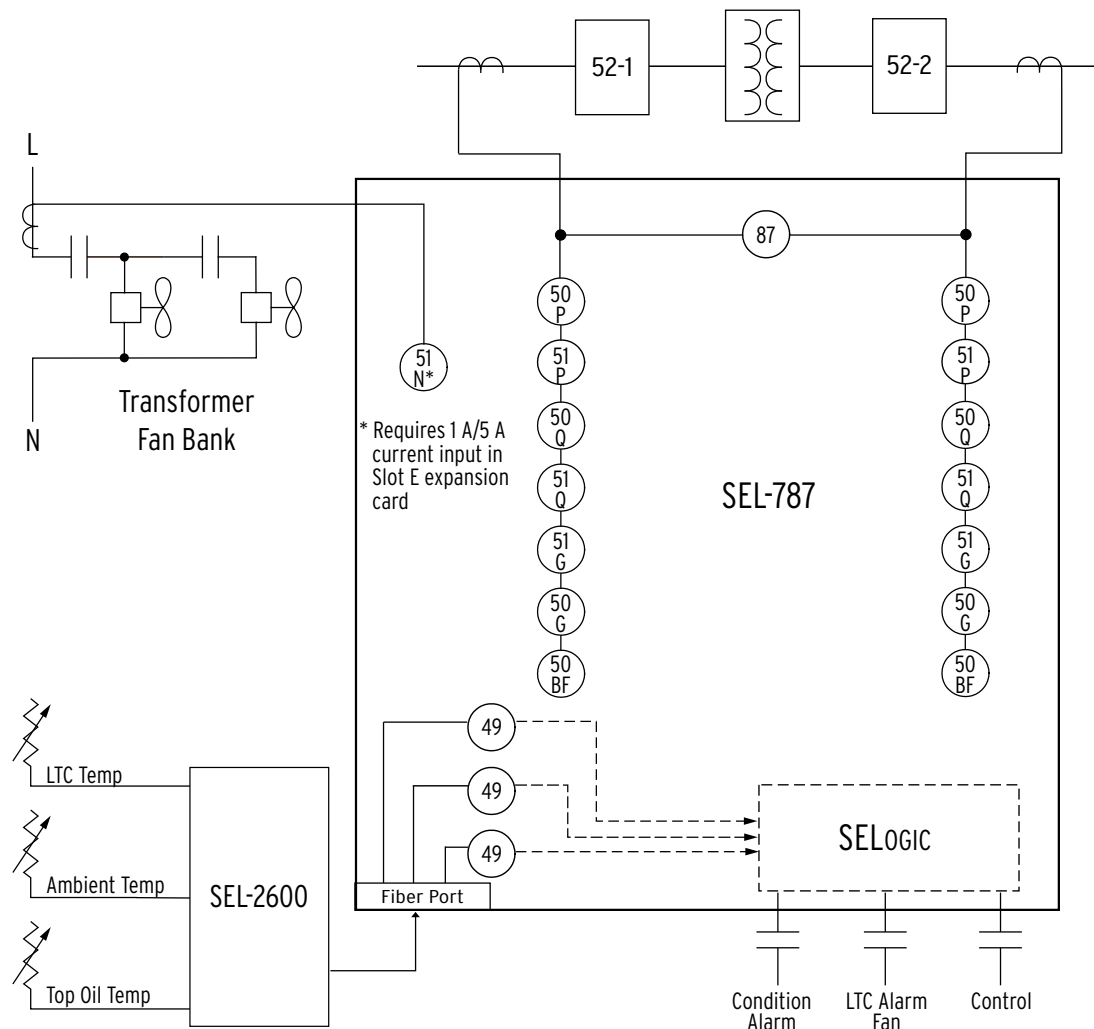

Figure 6 Transformer Fan Bank Control With LTC Monitoring

Relay and Logic Settings Software

QuickSet software simplifies settings and provides analysis support for the SEL-787. With QuickSet you have several ways to create and manage relay settings:

- ▶ Develop settings offline with an intelligent settings editor that only allows valid settings
- ▶ Create SELOGIC control equations with a drag-and-drop text editor
- ▶ Configure proper settings by using online help
- ▶ Organize settings with the relay database manager
- ▶ Load and retrieve settings through use of a simple PC communications link

With QuickSet, you can verify settings and analyze events and analyze power system events with the integrated waveform and harmonic analysis tools.

The following features of QuickSet can be used to monitor, commission, and test the SEL-787.

- ▶ Use the human-machine interface (HMI) to monitor meter data, Relay Word bits, and output contacts status during testing.
- ▶ Use the PC interface to remotely retrieve power system data.
- ▶ Use the Event Report Analysis Tool for easy retrieval and visualization of ac waveforms and digital inputs and outputs processed by the relay.
- ▶ Use the graphical current phasor displays in the HMI for visualizing differential current relationships.

Metering and Monitoring

The SEL-787 provides extensive metering capabilities. See *Specifications* for metering and power measurement accuracies. As shown in *Table 2*, metered quantities include phase voltages and currents, neutral currents;

sequence voltages and currents; harmonics, power, frequency, and energy; and maximum/minimum logging of selected quantities.

Table 2 SEL-787 Metered Values

Quantity	Description
I_{xWn} ($x = A, B, C$ $n = 1, 2$)	Winding phase current magnitude and angle, primary A
IN1	Neutral current magnitude and angle, primary A
$IGWn$ ($n = 1, 2$)	Residual-ground fault current and angle per winding, primary A
$3I2Wn$ ($n = 1, 2$)	Negative-sequence current and angle per winding, primary A
IOPz ($z = 1, 2, \text{ or } 3$)	Differential operate current, scaled to TAP
IRTz ($z = 1, 2, \text{ or } 3$)	Differential restraint current, scaled to TAP
$InF2, InF4, InF5$ ($n = 1, 2$)	Current harmonics, $InF2/IOPn$ (%) for second-, fourth-, fifth-harmonics
VA, VB, VC	Phase voltages and angles, primary volts, for wye-connected potential transformers
VAB, VBC, VCA	Phase-to-phase-phase voltages and angles, primary volts, for delta-connected potential transformers
VG	Residual-ground voltage and phase angle, primary volts, for wye-connected potential transformers
3V2	Negative-sequence voltage and phase angle, primary volts
kVA, kW, kVAR	Calculated apparent, real, and reactive power scaled to primary values
MWh, MVARh	Three-phase positive and negative megawatt-hours, megavolt-ampere reactive hour
PF	Power factor (leading or lagging)
V/Hz	Calculated volts/hertz in percent, using highest measured voltage and measured frequency
FREQ	Measured system frequency (Hz)
RTDn ($n = 1$ to 12)	RTD temperature measurement (degrees C)

Synchronized Phasor Measurement

Combine the SEL-787 with an SEL IRIG-B time source to measure the system angle in real time with a timing accuracy of $\pm 10 \mu\text{s}$. Measure instantaneous voltage and current phase angles in real time to improve system operation with synchrophasor information. Replace state measurement, study validation, or track system stability. Use SEL-5077 SYNCHROWAVE[®] Server Software or SEL-5078-2 SYNCHROWAVE[®] Console Software to view system angle at multiple locations for precise system analysis and system-state measurement (see *Figure 7*).

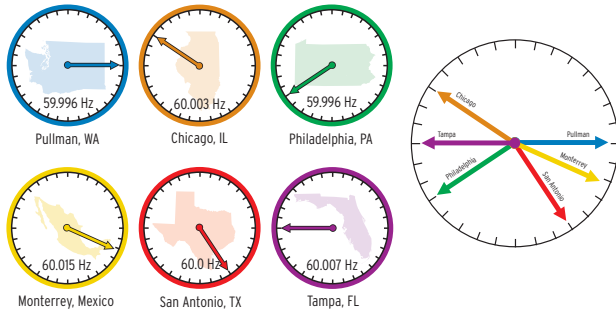

Figure 7 View of System Angle at Multiple Locations

Through-Fault Monitoring

A through fault is an overcurrent event external to the differential protection zone. While a through fault is not an in-zone event, the currents required to feed this external fault can cause great stress on the apparatus inside the differential protection zone. Through-fault currents can cause transformer winding displacement leading to mechanical damage and increased transformer thermal wear. An SEL-787 through-fault event monitor gathers current level, duration, and date/time for each through fault. The monitor also calculates a simple I^2t and cumulatively stores these data per phase. Use through-fault event data to schedule proactive transformer bank maintenance and help justify through-fault mitigation efforts. Apply the accumulated alarm capability of the relay to indicate excess through-fault current (I^2t) over time.

Event Reporting and Sequential Events Recorder (SER)

Event reports and the SER simplify post-fault analysis and improve understanding of simple and complex protective scheme operations. In response to a user-selected trigger, the voltage, current, frequency, and element status information contained in each event report confirms the relay scheme and system performance for every fault. Decide how much detail is necessary when you request an event report (e.g., 1/4-cycle or 1/16-cycle resolution, filtered or raw analog data).

The relay stores the most recent nineteen 64-cycle or seventy-seven 15-cycle event reports in nonvolatile memory. The relay always appends relay settings to the bottom of each event report.

The following analog data formats are available:

- 1/4-cycle or 1/16-cycle resolution
- Unfiltered or filtered analog
- ASCII or Compressed ASCII

The relay SER feature stores the latest 1024 entries. Use this feature to gain a broad perspective at a glance. An SER entry helps to monitor input/output change-of-state occurrences, element pickup/dropout.

The IRIG-B time-code input synchronizes the SEL-787 time to within $\pm 5 \text{ ms}$ of the time-source input. A convenient source for this time code is an SEL-2401 Satellite-Synchronized Clock or the SEL-2032, SEL-2030, or SEL-2020 Communications Processor (via serial Port 3 on the SEL-787).

Available reports, which also show the status of digital inputs and outputs, include:

- **Analog event reports** that use filtered data and show all analog channels at 4 samples per cycle
- **Digital event reports** that show pickup of protection elements including overcurrent, demand, voltage overexcitation, frequency, and over- and undervoltage elements at 4 samples per cycle
- **Differential event reports** that show differential quantities, element pickup, SELOGIC control equation set variables, and inputs and outputs at 4 samples per cycle
- **Raw analog event reports** that use unfiltered data at 16 samples per cycle

Automation

Flexible Control Logic and Integration Features

The SEL-787 is equipped with as many as four independently operated serial ports: one EIA-232 port on the front, one EIA-232 or EIA-485 port on the rear, one fiber-optic port, and one EIA-232 or EIA-485 port option card. The relay does not require special communications software. Use any system that emulates a standard terminal system for engineering access to the relay.

Establish communication by connecting computers, modems, protocol converters, printers, an SEL-2032, SEL-2030 or SEL-2020 Communications Processor, SCADA serial port, or an RTU for local or remote communication. Refer to *Table 3* for a list of communications protocols available in the SEL-787. Apply an SEL communications processor as the hub of a star network, with point-to-point fiber or copper connection between the hub and the SEL-787.

Table 3 Communications Protocols

Type	Description
Simple ASCII	Plain language commands for human and simple machine communications. Use for metering, setting, self-test status, event reporting, and other functions.
Compressed ASCII	Comma-delimited ASCII data reports. Allows external devices to obtain relay data in an appropriate format for direct import into spreadsheets and database programs. Data are checksum protected.
Extended Fast Meter and Fast Operate	Binary protocol for machine-to-machine communications. Quickly updates SEL-2032, SEL-2030, and SEL-2020 communications processors, RTUs, and other substation devices with metering information, relay element, I/O status, time-tags, open and close commands, and summary event reports. Data are checksum protected. Binary and ASCII protocols operate simultaneously over the same communications lines so control operator metering information is not lost while a technician is transferring an event report. Direct communications with the SEL-2600 RTD Module are possible using the unsolicited Fast Meter protocol to read incoming temperature data from the SEL-2600.
Fast SER Protocol	Provides SER events to an automated data collection system.
DNP3	Serial or Ethernet-based DNP3 protocols. Provide default and mappable DNP3 objects that include access to metering data, protection elements, Relay Word bits, contact I/O, targets, SER, relay summary event reports, and setting group selection.
Modbus	Serial- or Ethernet-based Modbus protocol with point remapping. Includes access to metering data, protection elements, contact I/O, targets, SER, relay summary event reports, and setting groups.
IEC 61850	Ethernet-based international standard for interoperability between intelligent devices in a substation. Operates remote bits and I/O. Monitors Relay Word bits and analog quantities.
Synchrophasors	IEEE C37.118-compliant synchrophasors for system state, response, and control capabilities.
Event Messenger	With the use of the SEL-3010 allows user to receive alerts sent directly to your cell phone. Alerts can be triggered through relay events and can include measured quantities by the relay.
DeviceNet	Allows for connection to a DeviceNet network for access to metering data, protection elements, contact I/O, targets, and setting groups.
SNTP	Ethernet-based protocol that provides time synchronization of the relay.

SEL-787 control logic improves integration in the following ways:

- **Replaces traditional panel control switches.** Eliminate traditional panel control switches with 32 local bits. Set, clear, or pulse local bits with the front-panel pushbuttons and display. Program the local bits into your control scheme with SELOGIC control equations. Use the local bits to perform functions such as a trip test or a breaker trip/close.
- **Eliminates RTU-to-relay wiring.** Eliminate RTU-to-relay wiring with 32 remote bits. Set, clear, or pulse remote bits through use of serial port commands. Program the remote bits into your control scheme with SELOGIC control equations. Use remote bits for SCADA-type control operations such as trip, close, and settings group selection.

- ▶ **Replaces traditional latching relays.** Replace as many as 32 traditional latching relays for such functions as “remote control enable” with latch bits. Program latch set and latch reset conditions with SELOGIC control equations. Set or reset the nonvolatile latch bits by using optoisolated inputs, remote bits, local bits, or any programmable logic condition. The latch bits retain their state when the relay loses power.
- ▶ **Replaces traditional indicating panel lights.** Replace traditional indicating panel lights with 32 programmable displays. Define custom messages (e.g., Breaker Open, Breaker Closed) to report power system or relay conditions on the front-panel display. Use advanced SELOGIC control equations to control what messages the relay displays.
- ▶ **Eliminates external timers.** Eliminate external timers for custom protection or control schemes with 32 general purpose SELOGIC control equation timers. Each timer has independent time-delay pickup and dropout settings. Program each timer input with the element you want (e.g., time qualify a current element). Assign the timer output to trip logic, transfer trip communications, or other control scheme logic.
- ▶ **Eliminates settings changes.** Selectable setting groups make the SEL-787 ideal for applications requiring frequent setting changes and for adapting the protection to changing system conditions. The relay stores four setting groups. Select the active

setting group by optoisolated input, command, or other programmable conditions. Use these setting groups to cover a wide range of protection and control contingencies. Switching setting groups switches logic and relay element settings. Program groups for different operating conditions, such as rental/spare transformer applications, station maintenance, seasonal operations, emergency contingencies, loading, source changes, and downstream relay setting changes.

Fast SER Protocol

SEL Fast Sequential Events Recorder (SER) protocol provides SER events to an automated data collection system. SEL Fast SER protocol is available on any rear serial port. Devices with embedded processing capability can use these messages to enable and accept unsolicited binary SER messages from SEL-787 relays. SEL relays and communications processors have two separate data streams that share the same serial port. The normal serial interface consists of ASCII character commands and reports that are intelligible to people using a terminal or terminal emulation package. The binary data streams can interrupt the ASCII data stream to obtain information, and then allow the ASCII data stream to continue. This mechanism allows a single communications channel to be used for ASCII communications (e.g., transmission of a long event report) interleaved with short bursts of binary data to support fast acquisition of metering or SER data.

Ethernet Network Architectures

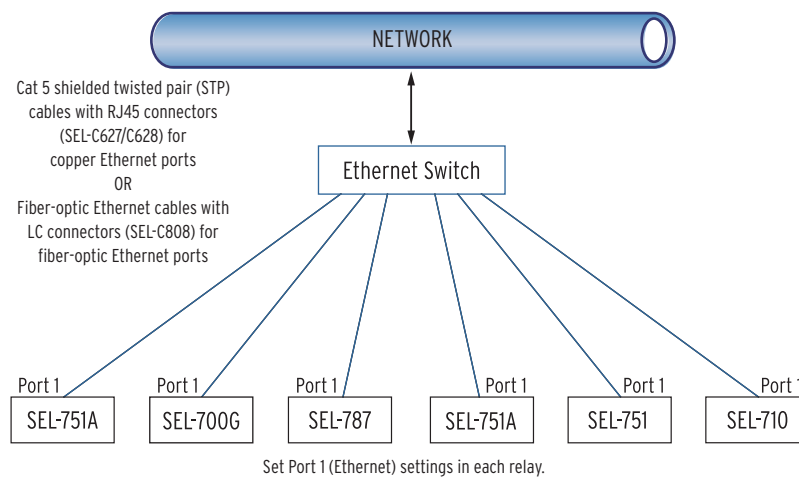

Figure 8 Simple Ethernet Network Configuration

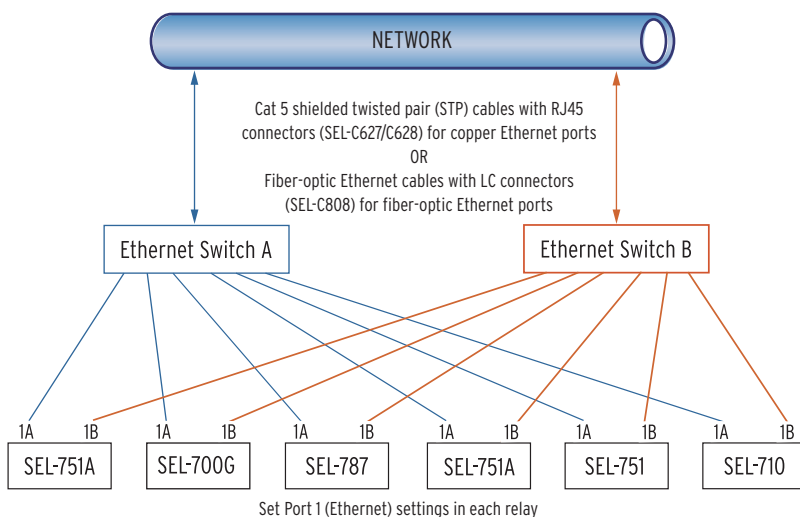

Figure 9 Simple Ethernet Network Configuration With Dual Redundant Connections (Failover Mode)

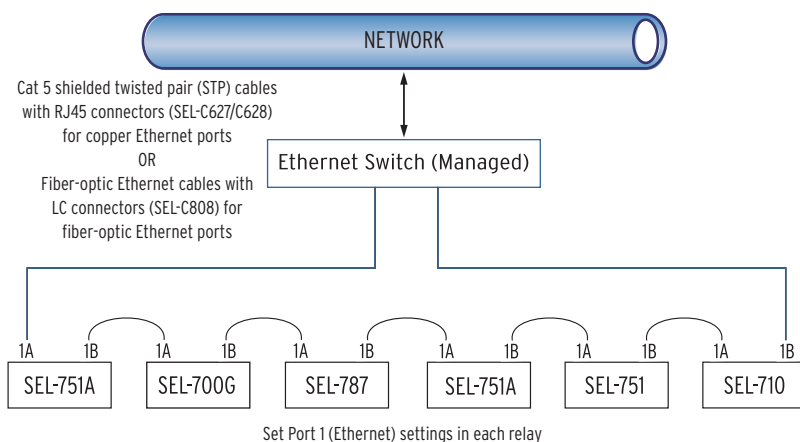

Figure 10 Simple Ethernet Network Configuration With Ring Structure (Switched Mode)

Additional Features

MIRRORED BITS Relay-to-Relay Communications

The SEL-patented MIRRORED BITS communications technology provides bidirectional relay-to-relay digital communication. The MIRRORED BITS technology can operate independently on as many as two EIA-232 rear serial ports and one fiber-optic rear serial port on a single SEL-787.

This bidirectional digital communication creates eight additional virtual outputs (transmitted MIRRORED BITS) and eight additional virtual inputs (received MIRRORED BITS) for each serial port operating in the MIRRORED BITS mode (see Figure 11). Use these MIRRORED BITS to transmit/receive information between upstream relays and a downstream relay to enhance

coordination and achieve faster tripping for downstream faults. MIRRORED BITS technology also helps reduce total scheme operating time by eliminating the need to assert output contacts to transmit information.

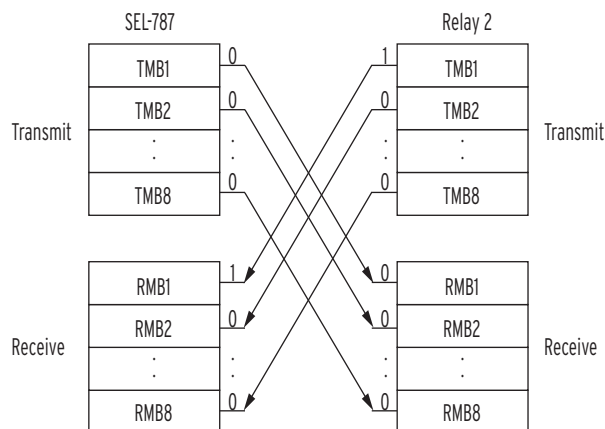

Figure 11 MIRRORED BITS Transmit and Receive Bits

Status and Trip Target LEDs

The SEL-787 includes 16 status and trip target LEDs on the front panel. When shipped from the factory, all LEDs are predefined and fixed in settings. You can reprogram these LEDs for specific applications. This combination of targets is explained and shown in *Figure 12*. Some front-panel relabeling of LEDs may be needed if you reprogram them for unique or specific applications—see *Configurable Labels*.

Event Messenger Points

The SEL-787, when used with the SEL-3010 Event Messenger, can allow for ASCII-to-voice translation of as many as 32 user-defined messages, along with analog data that have been measured or calculated by the relay. This combination can allow the user to receive voice messages on any phone for alerts to transition of any Relay Word bits in the relay.

Verbal notification of breaker openings, fuse failures, RTD alarms, etc. can now be sent directly to your cell phone through the use of your SEL-787 and SEL-3010 (must be connected to an analog telephone line). In addition, messages can include an analog value such as current, voltage, or power measurements made by the SEL-787.

Configurable Labels

Use the configurable labels to relabel the operator controls and LEDs (shown in *Figure 12*) to suit the installation requirements. This feature includes preprinted labels (with factory-default text), blank label media, and a Microsoft® Word template on CD-ROM. This allows for quick, professional-looking labels for the SEL-787. Labels may also be customized without the use of a PC by writing the new label on the blank stock provided. The ability to customize the control and indication features allows specific utility or industry procedures to be implemented without the need for adhesive labels. All of the figures in this data sheet show the factory-default labels of the SEL-787, including the standard model shown in *Figure 12*.

Additional Ordering Options

The following options can be ordered for any SEL-787 model (see the SEL-787 Model Option Table for details).

- Single- or dual-port Ethernet 10/100BASE-T or 100BASE-FX, Modbus TCP, SNTP, DNP3 Serial, DNP3 LAN/WAN, FTP, Telnet, IEC 61850
- EIA-232 or EIA-485 communications
- Additional EIA-232 or EIA-485 port
- Analog I/O (4 AI/4 AO)
- Digital I/O (4 DI/4 DO, 8 DI, 3 DI/4 DO/1 AO, 4 DI/3 DO)
- Three-Phase Voltage Inputs
- Single-Phase CT Input (1 A/5 A)
- 10 RTDs
- Conformal coating for chemically harsh and high-moisture environments

Wiring Diagram

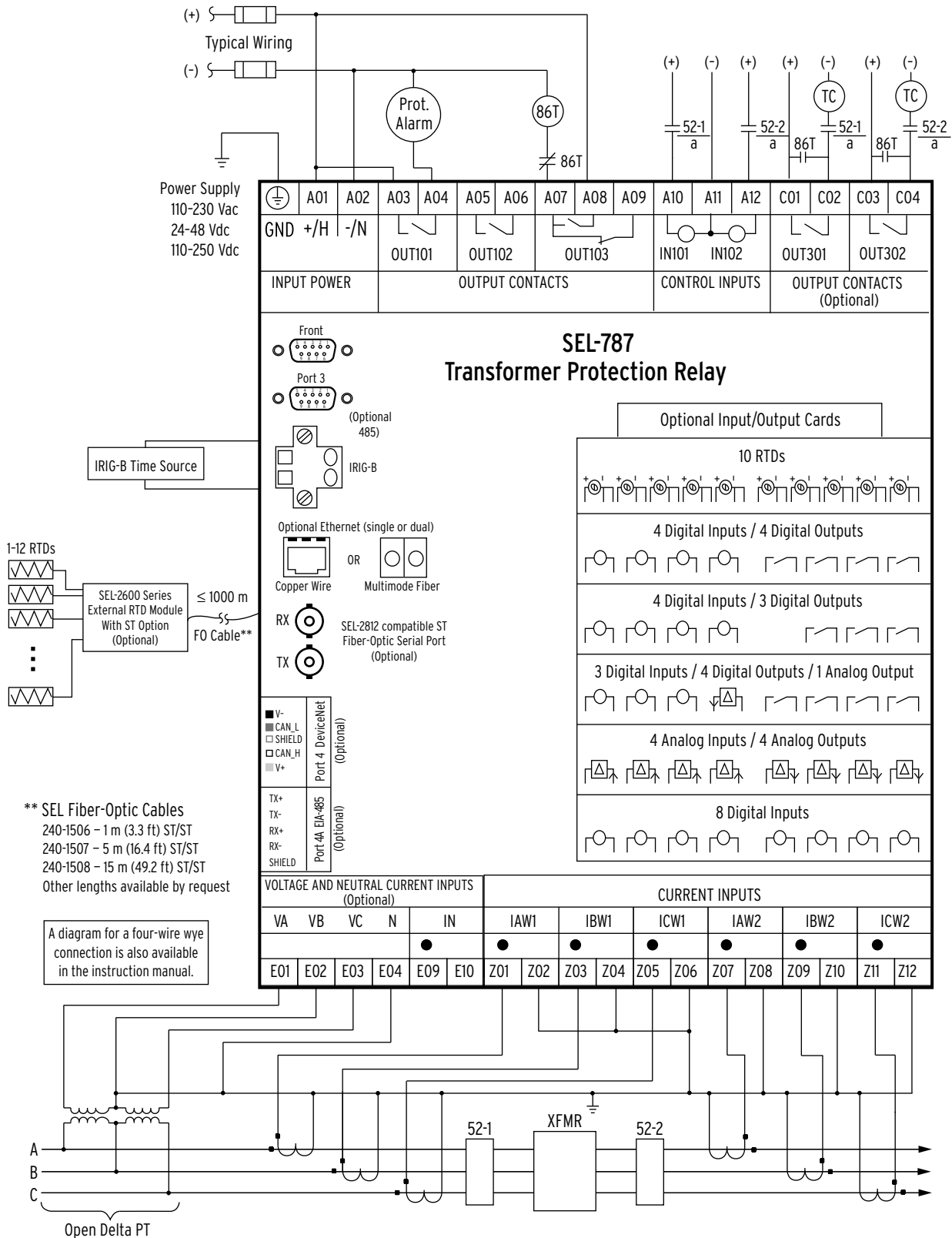

Panel Diagrams

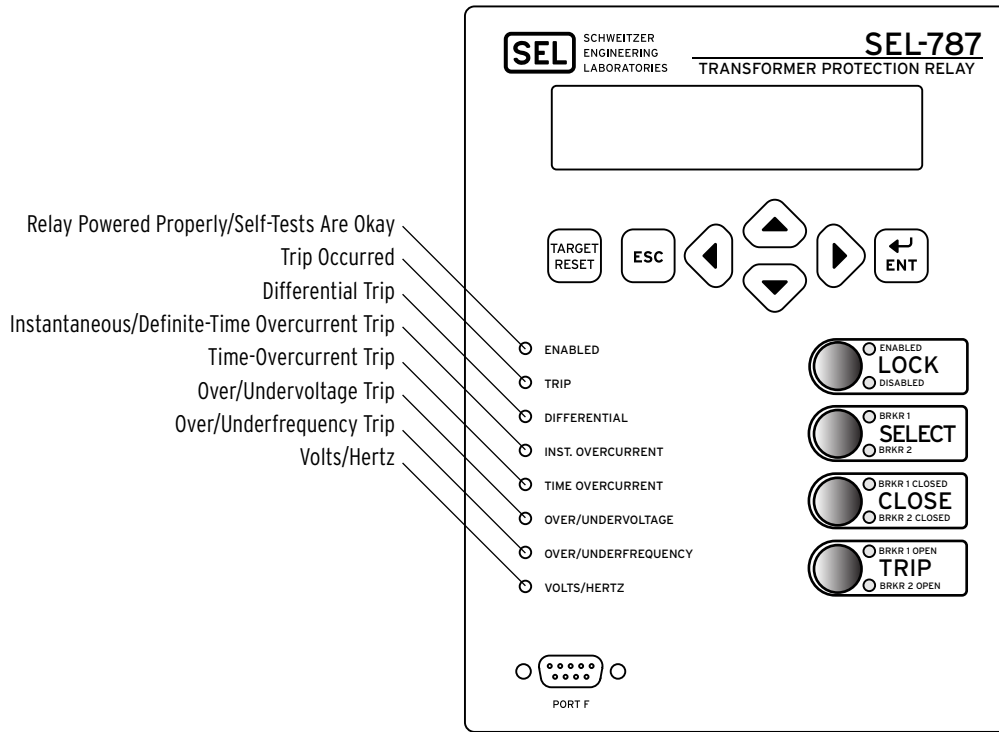
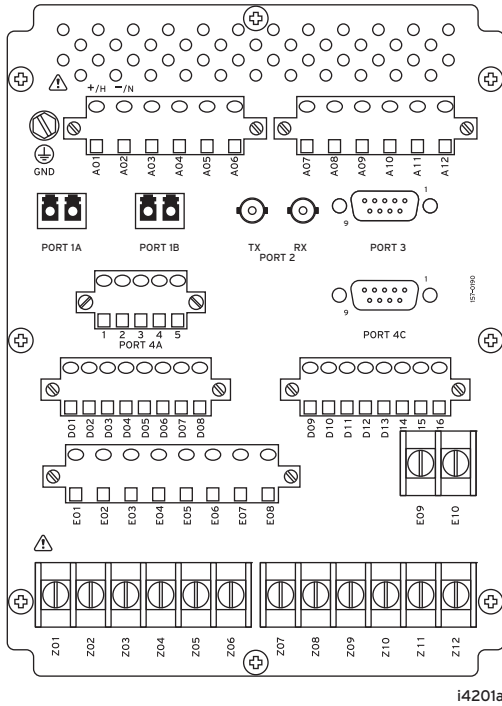
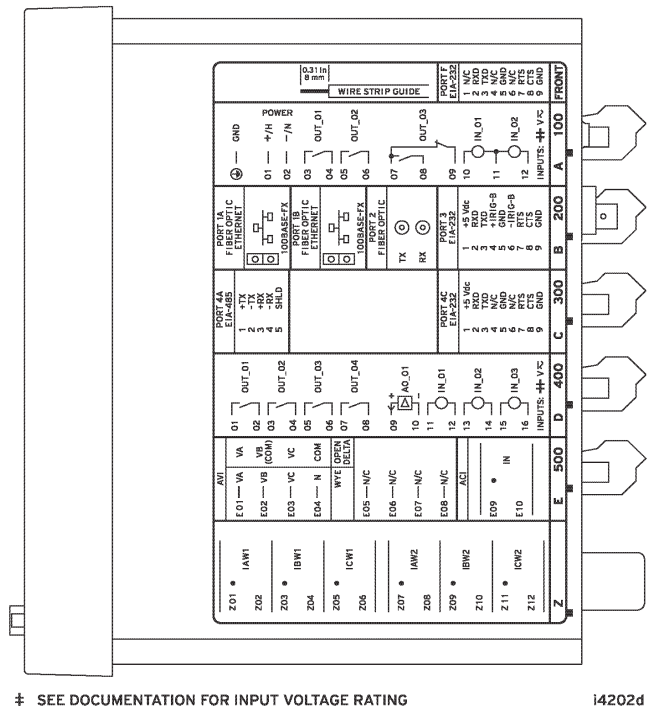

Figure 12 Front Panel With Default Configurable Labels



(A) Rear-Panel Layout



(B) Side-Panel Input and Output Designations

Figure 13 Dual-Fiber Ethernet, EIA-232 Communication, 3 DI/4 DO/1 AO, and Current/Voltage Option

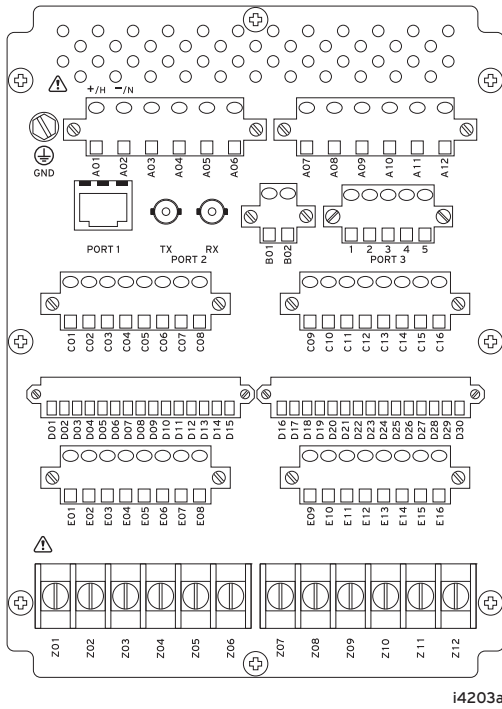

i4203a

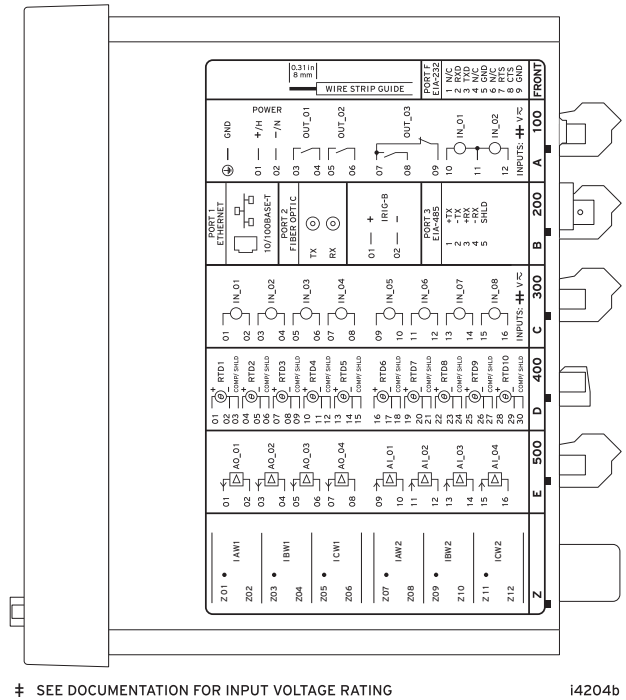

† SEE DOCUMENTATION FOR INPUT VOLTAGE RATING

i4204b

(A) Rear-Panel Layout

(B) Side-Panel Input and Output Designations

Figure 14 Single Copper Ethernet, 8 DI, RTD, and 4 AI/4 AO Option

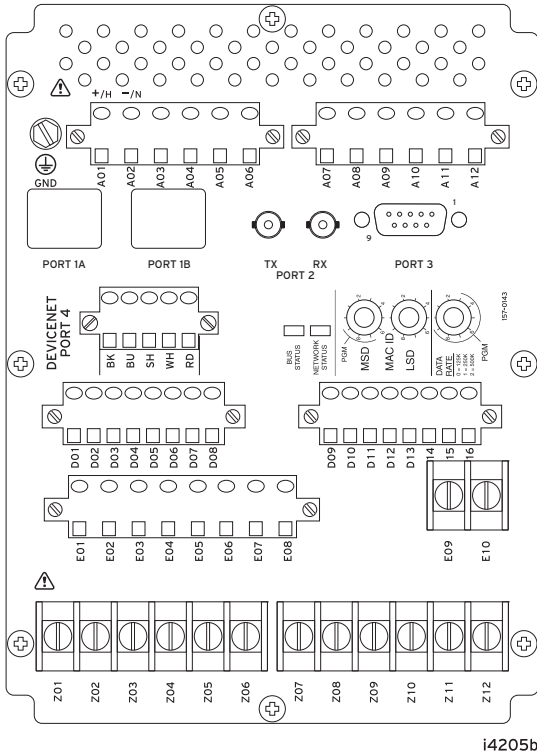

i4205b

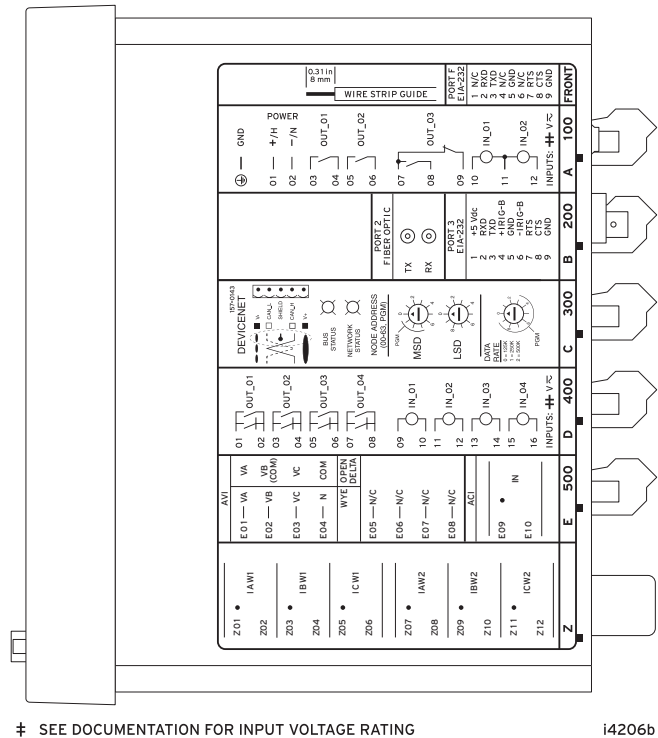

† SEE DOCUMENTATION FOR INPUT VOLTAGE RATING

i4206b

(A) Rear-Panel Layout

(B) Side-Panel Input and Output Designations

Figure 15 DeviceNet, Fast Hybrid 4 DI/4 DO, and Current/Voltage Option

Relay Dimensions

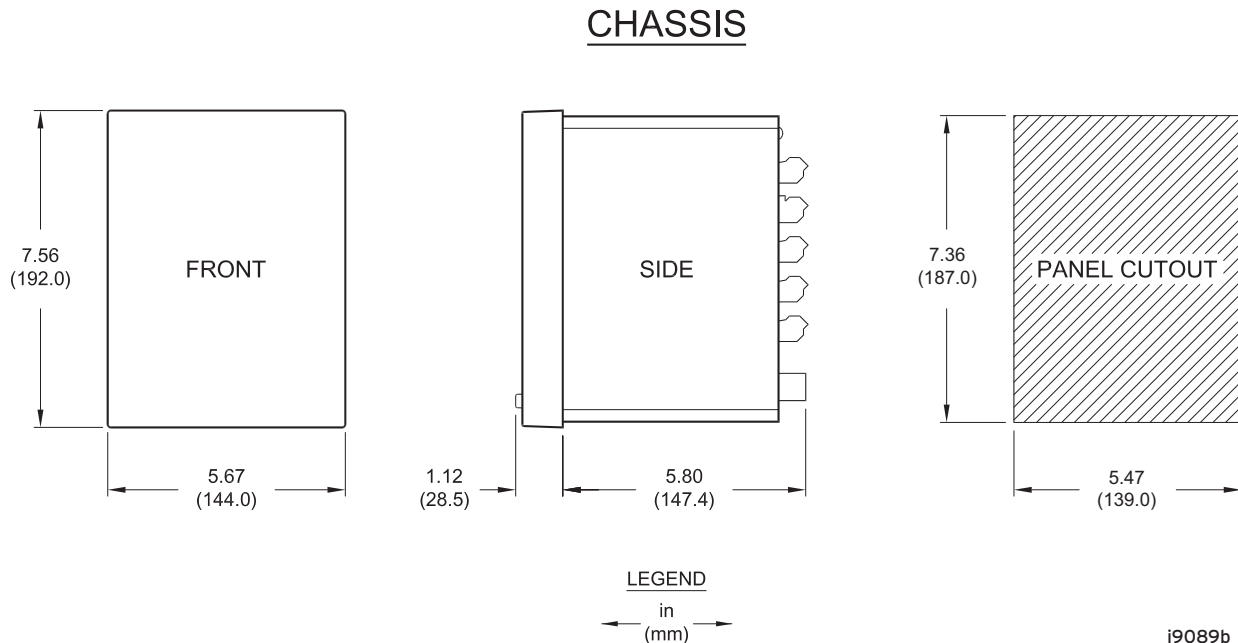

Figure 16 SEL-787 Dimensions for Rack- and Panel-Mount Models

Specifications

Compliance

Designed and manufactured under an ISO 9001 certified quality management system

47 CFR 15B, Class A

NOTE: This equipment has been tested and found to comply with the limits for a Class A digital device, pursuant to part 15 of the FCC Rules. These limits are designed to provide reasonable protection against harmful interference when the equipment is operated in a commercial environment. This equipment generates, uses, and can radiate radio frequency energy and, if not installed and used in accordance with the instruction manual, may cause harmful interference to radio communications. Operation of this equipment in a residential area is likely to cause harmful interference in which case the user will be required to correct the interference at his own expense.

UL Listed to U.S. and Canadian safety standards (File E212775; NRGU; NRGU7)

UL Certified for Hazardous Locations to U.S. and Canadian standards (File 4700448)

CE Mark

RCM Mark

General

AC Current Input

Phase and Neutral Currents

$I_{NOM} = 1 \text{ A}$ or 5 A secondary depending on model

$I_{NOM} = 5 \text{ A}$

Continuous Rating: 3 • I_{NOM} @ 85°C, linear to 100 A symmetrical
4 • I_{NOM} @ 55°C, linear to 100 A symmetrical

1-Second Thermal: 500 A

Burden (Per Phase): <0.1 VA @ 5 A

$I_{NOM} = 1 \text{ A}$

Continuous Rating: 3 • I_{NOM} @ 85°C, linear to 20 A symmetrical
4 • I_{NOM} @ 55°C, linear to 20 A symmetrical

1-Second Thermal: 100 A

Burden (Per Phase): <0.01 VA @ 1 A

Measurement Category: II

AC Voltage Inputs

VNOM (L-L secondary) 100–250 V (if DELTA_Y := DELTA)
Range: 100–440 V (if DELTA_Y := WYE)

Rated Continuous Voltage: 300 Vac

10 Second Thermal: 600 Vac

Burden: <0.1 VA

Input Impedance: 4 MΩ differential (phase-to-phase)
7 MΩ common mode (phase-to-chassis)

Power Supply

Relay Start-Up Time: Approximately 5–10 seconds (after power is applied until ENABLED LED turns on)

125/250 Vdc or 120/240 Vac

Rated Supply Voltage: 110–240 Vac, 50/60 Hz
110–250 Vdc

Input Voltage Range: 85–264 Vac
85–300 Vdc

Power Consumption: <40 VA (ac)
<20 W (dc)

Interruptions: 50 ms @ 125 Vac/Vdc
100 ms @ 250 Vac/Vdc

24/48 Vdc

Rated Supply Voltage: 24–48 Vdc
 Input Voltage Range: 19.2–60.0 Vdc
 Power Consumption: <20 W (dc)
 Interruptions: 10 ms @ 24 Vdc
 50 ms @ 48 Vdc

Fuse Ratings

LV Power Supply Fuse

Rating: 3.15 A
 Maximum Rated Voltage: 300 Vdc, 250 Vac
 Breaking Capacity: 1500 A at 250 Vac
 Type: Time-lag T

HV Power Supply Fuse

Rating: 3.15 A
 Maximum Rated Voltage: 300 Vdc, 250 Vac
 Breaking Capacity: 1500 A at 250 Vac
 Type: Time-lag T
 Heater Fuses F2, F3: 5 A, 125 V slow blow
 125 Vdc/50 A break rating

Fuses are not serviceable.

Output Contacts

The relay supports Form A, B, and C outputs.

Dielectric Test Voltages: 2500 Vac
 Impulse Withstand Voltage
 (U_{IMP}): 4700 V
 Mechanical Durability: 100,000 no-load operations

Standard Contacts

Pickup/Dropout Time: ≤ 8 ms (coil energization to contact closure)

DC Output Ratings

Rated Operational Voltage: 250 Vdc
 Rated Voltage Range: 19.2–275 Vdc
 Rated Insulation Voltage: 300 Vdc
 Make: 30 A @ 250 Vdc per IEEE C37.90
 Continuous Carry: 6 A @ 70°C
 4 A @ 85°C
 Thermal: 50 A for 1 s
 Contact Protection: 360 Vdc, 40 J MOV protection across open contacts

Breaking Capacity (10,000 Operations) per IEC 60255-0-20:1974:

24 Vdc	0.75 A	L/R = 40 ms
48 Vdc	0.50 A	L/R = 40 ms
125 Vdc	0.30 A	L/R = 40 ms
250 Vdc	0.20 A	L/R = 40 ms

Cyclic (2.5 Cycles/Second) per IEC 60255-0-20:1974:

24 Vdc	0.75 A	L/R = 40 ms
48 Vdc	0.50 A	L/R = 40 ms
125 Vdc	0.30 A	L/R = 40 ms
250 Vdc	0.20 A	L/R = 40 ms

AC Output Ratings

Maximum Operational Voltage (U_e) Rating: 240 Vac
 Insulation Voltage (U_i) Rating (excluding EN 61010-1): 300 Vac

Contact Rating Designation: B300

B300 (5 A Thermal Current, 300 Vac Max)			
	Maximum Current		Max VA
Voltage	120 Vac	240 Vac	—
Make	30 A	15 A	3600
Break	3 A	1.5 A	360
PF < 0.35, 50–60 Hz			

Utilization Category: AC-15

AC-15		
Operational Voltage (U_e)	120 Vac	240 Vac
Operational Current (I_e)	3 A	1.5 A
Make Current	30 A	15 A
Break Current	3 A	1.5 A
Electromagnetic loads > 72 VA, PF < 0.3, 50–60 Hz		

Voltage Protection Across

Open Contacts: 270 Vac, 40 J

Fast Hybrid (High-Speed, High-Current Interrupting)

DC Output Ratings

Rated Operational Voltage: 250 Vdc
 Rated Voltage Range: 19.2–275 Vdc
 Rated Insulation Voltage: 300 Vdc
 Make: 30 A @ 250 Vdc per IEEE C37.90
 Continuous Carry: 6 A @ 70°C
 4 A @ 85°C

1-Second Rating: 50 A

Open State Leakage Current: <500 μ A

MOV Protection (Maximum Voltage): 250 Vac/330 Vdc

Pickup Time: <50 μ s, resistive loadDropout Time: ≤ 8 ms, resistive load

Break Capacity (10,000 Operations) per IEC 60255-0-20:1974:

48 Vdc	10.0 A	L/R = 40 ms
125 Vdc	10.0 A	L/R = 40 ms
250 Vdc	10.0 A	L/R = 20 ms

Cyclic Capacity (4 Cycles in 1 Second, Followed by 2 Minutes Idle for Thermal Dissipation) per IEC 60255-0-20:1974:

48 Vdc	10.0 A	L/R = 40 ms
125 Vdc	10.0 A	L/R = 40 ms
250 Vdc	10.0 A	L/R = 20 ms

AC Output Ratings

See AC Output Ratings for Standard Contacts.

Optoisolated Control Inputs

When Used With DC Control Signals

250 V:	ON for 200–312.5 Vdc OFF below 150 Vdc
220 V:	ON for 176–275 Vdc OFF below 132 Vdc
125 V:	ON for 100–156.2 Vdc OFF below 75 Vdc
110 V:	ON for 88–137.5 Vdc OFF below 66 Vdc
48 V:	ON for 38.4–60 Vdc OFF below 28.8 Vdc
24 V:	ON for 15–30 Vdc OFF for <5 Vdc

When Used With AC Control Signals

250 V:	ON for 170.6–312.5 Vac OFF below 106 Vac
220 V:	ON for 150.2–275 Vac OFF below 93.3 Vac
125 V:	ON for 85–156.2 Vac OFF below 53 Vac
110 V:	ON for 75.1–137.5 Vac OFF below 46.6 Vac
48 V:	ON for 32.8–60 Vac OFF below 20.3 Vac
24 V:	ON for 14–30 Vac OFF below 5 Vac
Current draw at nominal dc voltage:	2 mA (at 220–250 V) 4 mA (at 48–125 V) 10 mA (at 24 V)

Rated Impulse Withstand Voltage (U_{imp}): 4000 V

Analog Output (Optional)

	1A0	4A0
Current:	4–20 mA	±20 mA
Voltage:	—	±10 V
Load at 1 mA:	—	0–15 kΩ
Load at 20 mA:	0–300 Ω	0–750 Ω
Load at 10 V:	—	>2000 Ω
Refresh Rate:	100 ms	100 ms
% Error, Full Scale, at 25°C:	<±1%	<±0.55%
Select From:	Analog quantities available in the relay	

Analog Inputs (Optional)

Maximum Input Range:	±20 mA ±10 V Operational range set by user
Input Impedance:	200 Ω (current mode) >10 kΩ (voltage mode)
Accuracy at 25°C:	
With user calibration:	0.05% of full scale (current mode) 0.025% of full scale (voltage mode)
Without user calibration:	Better than 0.5% of full scale at 25°C
Accuracy Variation With Temperature:	±0.015% per °C of full-scale (±20 mA or ±10 V)

Frequency and Phase Rotation

System Frequency:	50, 60 Hz
Phase Rotation:	ABC, ACB
Frequency Tracking:	20–70 Hz (requires ac voltage inputs option)

Time-Code Input

Format:	Demodulated IRIG-B
On (1) State:	$V_{ih} \geq 2.2$ V
Off (0) State:	$V_{il} \leq 0.8$ V
Input Impedance:	2 kΩ
Synchronization Accuracy:	
Internal Clock:	±1 μs
Synchrophasor Reports (e.g., MET PM):	±10 μs
All Other Reports:	±5 ms
Simple Network Time Protocol (SNTP) Accuracy:	
Internal Clock:	±5 ms
Unsynchronized Clock Drift Relay Powered:	2 minutes per year, typically

Communications Ports

Standard EIA-232 (2 ports)

Location:	Front Panel Rear Panel
Data Speed:	300–38400 bps

EIA-485 Port (optional)

Location:	Rear Panel
Data Speed:	300–19200 bps

Ethernet Port (optional)

Single/Dual 10/100BASE-T copper (RJ45 connector)
Single/Dual 100BASE-FX (LC connector)

Standard Multimode Fiber-Optic Port

Location:	Front Panel
Data Speed:	300–38400 bps

Fiber-Optic Ports Characteristics

Port 1 (or 1A, 1B) Ethernet

Wavelength:	1300 nm
Optical Connector Type:	LC
Fiber Type:	Multimode
Link Budget:	16.1 dB
Typical TX Power:	–15.7 dBm
RX Min. Sensitivity:	–31.8 dBm
Fiber Size:	62.5/125 μm
Approximate Range:	~6.4 km
Data Rate:	100 Mbps
Typical Fiber Attenuation:	–2 dB/km

Port 2 Serial (SEL-2812 compatible)

Wavelength:	820 nm
Optical Connector Type:	ST
Fiber Type:	Multimode
Link Budget:	8 dB
Typical TX Power:	–16 dBm
RX Min. Sensitivity:	–24 dBm
Fiber Size:	62.5/125 μm
Approximate Range:	~1 km
Data Rate:	5 Mbps
Typical Fiber Attenuation:	–4 dB/km

Optional Communications Cards

Option 1:	EIA-232 or EIA-485 communications card
Option 2:	DeviceNet communications card

Communications Protocols

SEL, Modbus, DNP, FTP, TCP/IP, Telnet, SNTP, IEC 61850, MIRRORRED BITS, EVMSG, C37.118 (synchrophasors), and DeviceNet. See *Table 7.3* for details.

Operating Temperature

IEC Performance Rating: –40° to +85°C (–40° to +185°F)
(per IEC/EN 60068-2-1 & 60068-2-2)

NOTE: Not applicable to UL applications.

NOTE: LCD contrast is impaired for temperatures below –20°C and above +70°C

DeviceNet Communications Card Rating: +60°C (140°F) maximum

Operating Environment

Pollution Degree:	2
Overvoltage Category:	II
Atmospheric Pressure:	80–110 kPa
Relative Humidity:	5%–95%, noncondensing
Maximum Altitude:	2000 m

Dimensions

144.0 mm (5.67 in.) x 192.0 mm (7.56 in.) x 147.4 mm (5.80 in.)

Weight

2.0 kg (4.4 lb)

Relay Mounting Screws (#8-32) Tightening Torque

Minimum: 1.4 Nm (12 in-lb)

Maximum: 1.7 Nm (15 in-lb)

Terminal Connections**Terminal Block**

Screw Size: #6

Ring Terminal Width: 0.310 in maximum

Terminal Block Tightening Torque

Minimum: 0.9 Nm (8 in-lb)

Maximum: 1.4 Nm (12 in-lb)

Compression Plug Tightening Torque

Minimum: 0.5 Nm (4.4 in-lb)

Maximum: 1.0 Nm (8.8 in-lb)

Compression Plug Mounting Ear Screw Tightening Torque

Minimum: 0.18 Nm (1.6 in-lb)

Maximum: 0.25 Nm (2.2 in-lb)

Type Tests**Environmental Tests**

Enclosure Protection:	IEC 60529:2001 + CRDG:2003 IP65 enclosed in panel IP20 for terminals IP50 for terminals enclosed in the dust-protection assembly (protection against solid foreign objects only, SEL Part #915900170). 10°C temperature derating applies to the temperature specifications of the relay.
Vibration Resistance:	IEC 60255-21-1:1988, Class 1 Endurance Class 2 Response IEC 60255-21-3:1993, Class 2
Shock Resistance:	IEC 60255-21-2:1988, Class 1 Shock Withstand, Bump Class 2 Shock Response
Cold:	IEC 60068-2-1:2007 -40°C, 16 hours
Damp Heat, Steady State:	IEC 60068-2-78:2001 40°C, 93% relative humidity, 4 days
Damp Heat, Cyclic:	IEC 60068-2-30:2005 25–55°C, 6 cycles, 95% relative humidity
Dry Heat:	IEC 60068-2-2:2007 85°C, 16 hours

Dielectric Strength and Impulse Tests

Dielectric (HiPot):	IEC 60255-5:2000 IEEE C37.90-2005 2.5 kVac on current inputs, ac voltage inputs, contact I/O 2.0 kVac on analog inputs 1.0 kVac on analog outputs 2.83 kVdc on power supply
Impulse:	IEC 60255-5:2000 IEEE C37.90-2005 0.5 J, 4.7 kV on power supply, contact I/O, ac current and voltage inputs 0.5 J, 530 V on analog outputs

RFI and Interference Tests**EMC Immunity**

Electrostatic Discharge Immunity:	IEC 61000-4-2:2008 IEC 60255-22-2:2008 Severity Level 4 8 kV contact discharge 15 kV air discharge
Radiated RF Immunity:	IEC 61000-4-3:2010 IEC 60255-22-3:2007 10 V/m IEEE C37.90.2-2004 35 V/m
Digital Radio Telephone RF Immunity:	ENV 50204:1995
Fast Transient, Burst Immunity:	IEC 61000-4-4:2004 IEC 60255-22-4:2008 4 kV @ 5.0 kHz 2 kV @ 5.0 kHz for comm. ports
Surge Immunity:	IEC 61000-4-5:2005 IEC 60255-22-5:2008 2 kV line-to-line 4 kV line-to-earth
Surge Withstand Capability Immunity:	IEC 60255-22-1:2007 2.5 kV common mode 1.0 kV differential mode 1 kV common mode on comm. ports IEEE C37.90.1-2002 2.5 kV oscillatory 4 kV fast transient
Conducted RF Immunity:	IEC 61000-4-6:2008 IEC 60255-22-6:2001 10 Vrms
Magnetic Field Immunity:	IEC 61000-4-8:2009 1000 A/m for 3 seconds 100 A/m for 1 minute IEC 61000-4-9:2001 1000 A/m
Power Supply Immunity:	IEC 60255-11:2008
EMC Emissions	
Conducted Emissions:	EN 55011:1998, Class A IEC 60255-25:2000
Radiated Emissions:	EN 55011:1998, Class A IEC 60255-25:2000
Electromagnetic Compatibility	
Product Specific:	EN 50263:1999

Processing Specifications and Oscillography

AC Voltage and Current Inputs:	16 samples per power system cycle
Frequency Tracking Range:	20–70 Hz (requires ac voltage inputs option)
Digital Filtering:	One-cycle cosine after low-pass analog filtering. Net filtering (analog plus digital) rejects dc and all harmonics greater than the fundamental.
Protection and Control Processing:	Processing interval is 4 times per power system cycle (except for math variables and analog quantities, which are processed every 100 ms). The 51 elements are processed 2 times per power system cycle.
Oscillography	
Length:	15 or 64 cycles
Sampling Rate:	16 samples per cycle unfiltered 4 samples per cycle filtered
Trigger:	Programmable with Boolean expression
Format:	ASCII and Compressed ASCII

Time-Stamp Resolution:	1 ms
Time-Stamp Accuracy:	±5 ms

Sequential Events Recorder

Time-Stamp Resolution:	1 ms
Time-Stamp Accuracy (with respect to time source):	±5 ms

Relay Elements**Instantaneous/Definite-Time Overcurrent (50P, 50G, 50N, 50Q)**

Pickup Setting Range, A secondary:	
5 A models:	0.50–96.00 A, 0.01 A steps
1 A models:	0.10–19.20 A, 0.01 A steps
Accuracy:	±5% of setting plus $\pm 0.02 \cdot I_{NOM}$ A secondary (Steady State pickup)
Time Delay:	0.00–5.00 seconds, 0.01-second steps, $\pm 0.5\%$ plus ± 0.25 cyc
Pickup/Dropout Time:	<1.5 cyc

Inverse Time Overcurrent (51P, 51G, 51N, 51Q)

Pickup Setting Range, A secondary:	
5 A models:	0.50–16.00 A, 0.01 A steps
1 A models:	0.10–3.20 A, 0.01 A steps
Accuracy:	±5% of setting plus $\pm 0.02 \cdot I_{NOM}$ A secondary (Steady State pickup)
Time Dial:	
US:	0.50–15.00, 0.01 steps
IEC:	0.05–1.00, 0.01 steps
Accuracy:	±1.5 cycles plus $\pm 4\%$ between 2 and 30 multiples of pickup (within rated range of current)

Differential (87)

Unrestrained Pickup Range:	1.0–20.0 in per unit of TAP
Restrained Pickup Range:	0.10–1.00 in per unit of TAP
Pickup Accuracy (A secondary):	
5 A Model:	±5% plus ± 0.10 A
1 A Model:	±5% plus ± 0.02 A
Unrestrained Element	
Pickup Time:	0.8/1.0/1.9 cycles (Min/Typ/Max)
Restrained Element (with harmonic blocking)	
Pickup Time:	1.5/1.6/2.2 cycles (Min/Typ/Max)
Restrained Element (with harmonic restraint)	
Pickup Time:	2.62/2.72/2.86 cycles (Min/Typ/Max)

Harmonics

Pickup Range (% of fundamental):	5%–100%
Pickup Accuracy (A secondary):	
5 A Model:	±5% plus ± 0.10 A
1 A Model:	±5% plus ± 0.02 A
Time Delay Accuracy:	±0.5% plus ± 0.25 cycle

Restricted Earth Fault (REF)

Pickup Range (per unit of I_{NOM} of neutral current input, IN):	0.05–3.00 per unit, 0.01 per-unit steps
Pickup Accuracy (A secondary):	
5 A Model:	±5% plus ± 0.10 A
1 A Model:	±5% plus ± 0.02 A
Timing Accuracy:	
Directional Output:	1.5 ± 0.25 cyc
ANSI Extremely Inverse TOC Curve (U4 With 0.5 Time Dial):	±5 cycles plus $\pm 5\%$ between 2 and 30 multiples of pickup (within rated range of current)

Undervoltage (27)

Setting Range:	Off, 12.5–300.0 V
Accuracy:	±1% of setting plus ± 0.5 V
Pickup/Dropout Time:	<1.5 cycle
Time Delay:	0.0–120.0 seconds, 0.1-second steps
Accuracy:	±0.5% plus ± 0.25 cycle

Overvoltage (59)

Setting Range:	Off, 12.5–300.0 V
Accuracy:	±1% of setting plus ± 0.5 V
Pickup/Dropout Time:	<1.5 cycle
Time Delay:	0.0–120.0 seconds, 0.1-second steps
Accuracy:	±0.5% plus ± 0.25 cycle

Negative-Sequence Overvoltage (59Q)

Setting Range:	12.5–200.0 V
Accuracy:	±5% of setting plus ± 2 V
Pickup/Dropout Time:	<1.5 cycle
Time Delay:	0.0–120.0 seconds, 0.1-second steps
Accuracy:	±0.5% plus ± 0.25 cycle

Volts/Hertz (24)

Definite-Time Element	
Pickup Range:	100%–200%
Steady-State Pickup Accuracy:	±1% of set point
Pickup Time:	25 ms @ 60 Hz (Max)
Time-Delay Range:	0.00–400.00 s
Time-Delay Accuracy:	±0.1% plus ± 4.2 ms @ 60 Hz
Reset Time Range:	0.00–400.00 s
Inverse-Time Element	
Pickup Range:	100%–200%
Steady-State Pickup Accuracy:	±1% of set point
Pickup Time:	25 ms @ 60 Hz (Max)
Curve:	0.5, 1.0, or 2.0
Factor:	0.1–10.0 s
Timing Accuracy:	±4% plus ± 25 ms @ 60 Hz, for V/Hz above 1.05 multiples (Curve 0.5 and 1.0) or 1.10 multiples (Curve 2.0) of pickup setting, and for operating times >4 s
Reset Time Range:	0.00–400.00 s
Composite-Time Element	
Combination of definite-time and inverse-time specifications	
User-Definable Curve Element	
Pickup Range:	100%–200%
Steady-State Pickup Accuracy:	±1% of set point
Pickup Time:	25 ms @ 60 Hz (Max)
Reset Time Range:	0.00–400.00 s

Directional Power (32)

Instantaneous/Definite Time, 3 Phase Elements	
Type:	+W, –W, +VAR, –VAR
Pickup Settings Range, VA secondary:	
5 A Model:	1.0–6500.0 VA, 0.1 VA steps
1 A Model:	0.2–1300.0 VA, 0.1 VA steps

Accuracy:	$\pm 0.10 \text{ A} \cdot (\text{L-L voltage secondary})$ and $\pm 5\%$ of setting at unity power factor for power elements and zero power factor for reactive power element (5 A nominal) $\pm 0.02 \text{ A} \cdot (\text{L-L voltage secondary})$ and $\pm 5\%$ of setting at unity power factor for power elements and zero power factor for reactive power element (1 A nominal)
Pickup/Dropout Time:	<10 cycles
Time Delay:	0.0–240.0 seconds, 0.1-second steps
Accuracy:	$\pm 0.5\%$ plus ± 0.25 cycle

Frequency (81) (requires ac voltage option)

Setting Range:	Off, 20.0–70.0 Hz
Accuracy:	$\pm 0.01 \text{ Hz}$ ($V_1 > 60 \text{ V}$) with voltage tracking
Pickup/Dropout Time:	<4 cycles
Time Delay:	0.0–240.0 seconds, 0.1-second steps
Accuracy:	$\pm 0.5\%$ plus ± 0.25 cycle

RTD Protection

Setting Range:	Off, 1°–250°C
Accuracy:	$\pm 2^\circ\text{C}$
RTD Open-Circuit Detection:	$>250^\circ\text{C}$
RTD Short-Circuit Detection:	$<-50^\circ\text{C}$
RTD Types:	PT100, NI100, NI120, CU10
RTD Lead Resistance:	25 ohm max. per lead
Update Rate:	<3 s
Noise Immunity on RTD Inputs:	To 1.4 Vac (peak) at 50 Hz or greater frequency
RTD Trip/Alarm Time Delay:	Approx. 6 s

Metering Accuracy

Accuracies are specified at 20°C, nominal frequency, ac currents within (0.2–20.0) • I_{NOM} A secondary, and ac voltages within 50–250 V secondary unless otherwise noted.

Phase Currents:	$\pm 1\%$ of reading, $\pm 1^\circ$ ($\pm 2.5^\circ$ at 0.2–0.5 A for relays with $I_{\text{nom}} = 1 \text{ A}$)
3-Phase Average Current:	$\pm 2\%$ of reading
Differential Quantities:	$\pm 5\%$ of reading plus $\pm 0.1 \text{ A}$ (5 A nominal), $\pm 0.02 \text{ A}$ (1 A nominal)
Current Harmonics:	$\pm 5\%$ of reading plus $\pm 0.1 \text{ A}$ (5 A nominal), $\pm 0.02 \text{ A}$ (1 A nominal)
IG (Residual Current):	$\pm 3\%$ of reading, $\pm 2^\circ$ ($\pm 5.0^\circ$ at 0.2–0.5 A for relays with $I_{\text{nom}} = 1 \text{ A}$)
IN (Neutral Current):	$\pm 1\%$ of reading, $\pm 1^\circ$ ($\pm 2.5^\circ$ at 0.2–0.5 A for relays with $I_{\text{nom}} = 1 \text{ A}$)
3I2 Negative-Sequence Current:	$\pm 3\%$ of reading