

Product Guide



Features

- Flexible, field-customizable 16-channel annunciator unit
- Alarm channels activated by normally open or normally closed contact
- Four +16 output relays: two for group realarms, one for an audible device, one for the self-supervision system and an additional sixteen relays for use as field contact follower outputs or group realarm outputs
- Parameter selection and adjustment from front panel or via serial interface
- First-out alarm indication with clear four-digit display on the front panel
- Extensive data communication via the serial interface and the SPA bus
- Sophisticated hardware and software self-supervision system for maximum operational reliability under the most demanding environmental conditions
- Powerful software support for parameterization of the unit via the serial interface
- Member of the SPACOM product family, ABB's Distribution Automation systemt
- CE marking according to the EC directive for EMC

Application

The digital annunciator unit is used in a variety of applications requiring supervision of alarm and signalling contacts in power plants, substations and industrial process installations. The alarm unit is also approved for use in off-shore installations and marine applications. Further, the annunciator unit can be used in any application where on/off signals are to be supervised.

The annunciator unit provides immediate fault recognition, fault identification and visual and audible alarm in an abnormal process situation. The annunciator unit also pro-

vides a means for subsequent fault analyses, which means that corrective measures can be carried out without delay and full control of the process can be maintained.

The annunciator units can be used either as independent stand-alone units, or they can be connected together via a fibre-optic bus to form complete supervision, event sequence reporting and data acquisition systems.

The annunciator unit is a member of SPACOM, the ultimate integrated secondary equipment system for power systems.

Design

The annunciator unit is composed of five modules, i.e. an alarm annunciator module, an input/output module, a connection module, an output relay module and a power module, housed in a rugged aluminium casing.

The alarm annunciator module includes 16 alarm channels. The channels are activated by normally open or normally closed process contacts. The required 48 V dc contact circuit voltage is generated and supervised by the annunciator unit. Each channel can separately be assigned a start delay from 5 ms to 160 s.

On activation of a channel the visual indicator of the channels starts blinking. One of five standardized blinking systems according to ISA and DIN can be selected by the operator at commissioning.

The annunciator is provided with a first-out indication given via the four-digit alphanumeric display on the front panel. The first-out alarm is indicated with a letter A and the channel number.

The annunciator unit is also provided with an event register, which stores the last nine events in chronological order. The event register can be read via the push-buttons and the display on the front panel or via the serial interface.

The annunciator holds four output relays, two of which are used as group alarm output relays. One of five modes of operation can be selected for the realarm output relays. An additional 16 output relays are located on a separate module. These relays can be used as field contact follower outputs or as group realarm output relays.

One output relay is dedicated for the self-supervision system and one for the control of an audible device, such as a buzzer or a horn.

Any information generated in the annunciator unit can be read by a hierarchically superior system via the serial interface.

Data communication

The annunciator unit is provided with a serial interface on the rear panel. By means of a bus connection module type SPA-ZC 17/S or SPA-ZC 21/S the unit can be connected to the fibre-optic SPA bus. The bus connection module type SPA-ZC 21/S is powered from the host unit, whereas the bus connection module SPA-ZC 17/S is provided with a built-in power unit, which can be fed from an external secured power source. The unit communicates with higher-level data acquisition and control systems over the SPA bus.

Self-supervision

The annunciator incorporates a sophisticated self-supervision system which increases the availability of the device and the reliability of the system. The self-supervision system continuously monitors the hardware and the software of the unit. The system also supervises the operation of the auxiliary supply module and the level of the electronics' voltages generated by the module.

If a permanent fault is detected, the fault indicator on the front panel is lit, the output relay of the self-supervision system operates and the outputs are blocked.

Auxiliary supply voltage

The auxiliary supply of the relay is obtained from an internal plug-in type power supply module. Two auxiliary power module types are available: type SPGU 240A1 for the supply voltage range 80...265 V ac/dc and type SPGU 48B2 for the supply voltage range 18...80 V dc. The power supply module forms the internal voltages required by the annunciator.

Technical data

Table 1: Alarm channels

| | |
|---|---|
| Capacity | 16 channels |
| Type of field contact or type of incoming alarm signal | Make contact (default) Break contact Rising edge Falling edge Pulse counter, max. 3 Hz, 0...29.999 |
| Field contact voltage | 48 V dc \pm 20% |
| Loop current of closed field contact circuit | 4 mA \pm 20% |
| Channel input and reset delay time, field-selectable values | 5 ms, 20 ms (default), 100 ms, 1 s, 5 s, 20 s, 60 s or 160 s. (Other values possible via the serial communication.) |

Table 2: External acknowledge/reset inputs

| | |
|---|-------------------|
| Channel acknowledge/reset | Make contact |
| Audible device reset | Make contact |
| The control voltages for the acknowledge/reset circuits are obtained from the internal supply | 48 V dc \pm 20% |

Table 3: Reflash signal outputs

| | |
|--|--|
| Reflash group alarm outputs | 2 relays, NO contact (NC by soldering) |
| Audible device output | 1 relay |
| Internal self-supervision output | 1 relay |
| Additional field contact follower or group alarm output relays by means of module SWOM 16A1 | 16 relays |
| Rated contact current/breaking voltage | 3 A/250 V ac/dc |
| Breaking capacity for dc currents when the load time-constant $L/R \leq 40$ ms at the voltage levels 48/110/220 V dc | 1 A/0.25 A/0.15 A |

Table 4: Data communication

| | | |
|---|-------------------------|---------------|
| Transmission mode | Fibre-optic serial bus | |
| Coding | ASCII | |
| Data transfer, selectable | 4800 or 9600 Bd | |
| Electrical/optical bus connection module, powered from the host unit | for plastic core cables | SPA-ZC 21BB/S |
| | for glass fibre cables | SPA-ZC 21MM/S |
| Electrical/optical bus connection module, powered from the host unit or from an external power source | for plastic core cables | SPA-ZC 17BB/S |
| | for glass fibre cables | SPA-ZC 17MM/S |

Table 5: Auxiliary supply modules

| | | | |
|----------------|--|----------------------|--|
| Type of module | SPGU 240A1 | rated voltages U_n | 110/120/230/240 V ac 110/125/220 V dc |
| | | operative range | 80...265 V ac/dc |
| | SPGU 48B2 | rated voltages U_n | 24/48/60 V ac |
| | | operative range | 18...80 V dc |
| | Power consumption under quiescent/operation conditions | | ~10 W/~25 W |

Table 6: Tests and standards

| | | |
|--------------------------|---|------------------------|
| Test voltages | - alarm and acknowledge/reset inputs to frame - output relay contacts to frame - auxiliary supply circuits to frame - inputs, outputs and supply circuits between themselves | |
| | Dielectric test voltage (IEC 60255-5) | 2 kV, 50 Hz, 1 min |
| | Impulse test voltage (IEC 60255-5) | 5 kV, 1.2/50 μs, 0.5 J |
| Disturbance tests | HF test voltage (IEC 60255-6) | 2.5 kV, 1 MHz |
| Environmental conditions | Ambient service temperature range | -10...+55°C |
| | Ambient transport and storage temperature range | -40...+70°C |
| | Long term damp heat withstand (IEC 60068-2-3) | <95%, +40°C, 56 d/a |
| | Degree of protection by enclosure when panel-mounted | IP 54 |
| | Weight | ~4.5 kg |

Block diagram

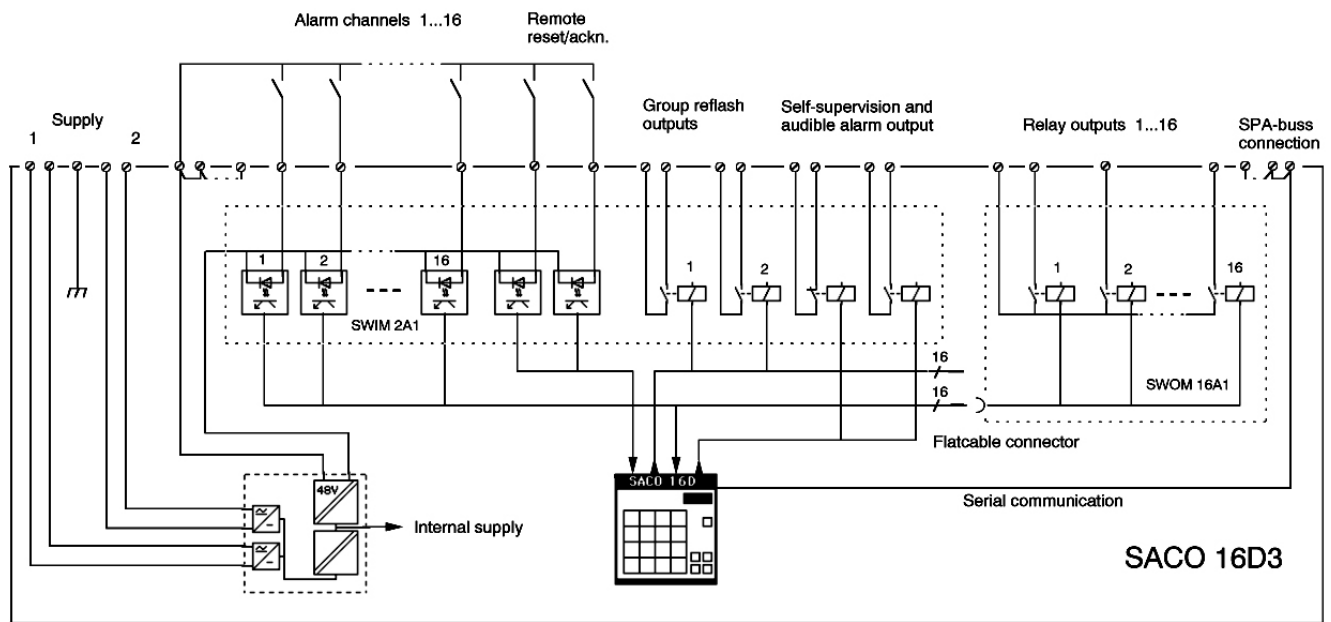

baco16d3_block

Fig. 1 Block diagram

Mounting and dimensions

Flush mounting

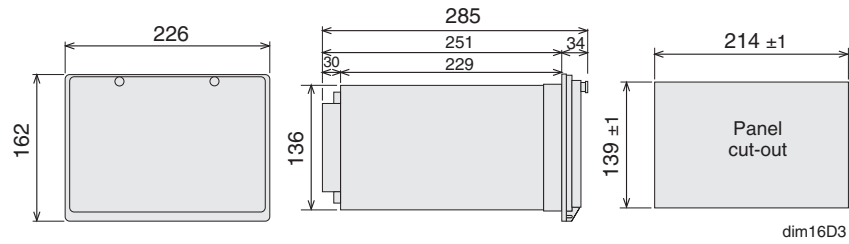

Fig. 2 Flush-mounting relay case (dimensions in mm)

Semi-flush mounting



Fig. 3 Semi-flush mounting relay case (dimensions in mm)

Mounting in 19 inch cabinets and frames

An ancillary mounting plate, height 4U (~177 mm), is recommended to be used when the annunciators are to be mounted in 19 inch frames or cabinets. The ancillary mounting

plate type SPA-ZX 104 accommodates three units, type SPA-ZX 105 two units and type SPA-ZX 106 one unit.

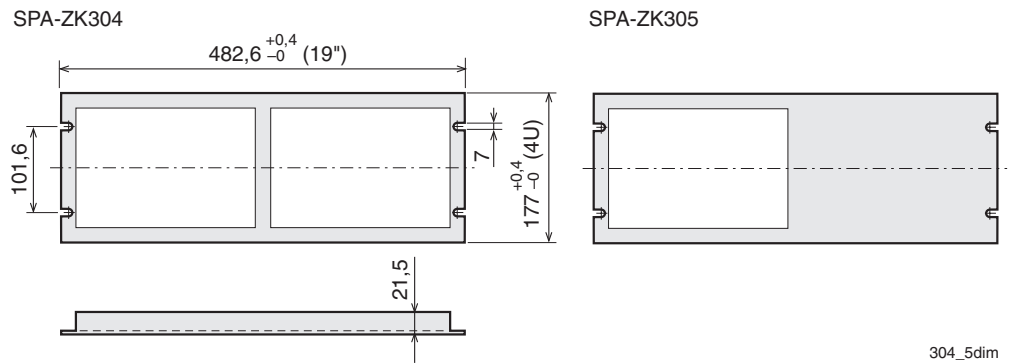

Fig. 4 Mounting cabinets and frames (dimensions in mm)

Ordering**When ordering, please specify:**

| Ordering information | Ordering example |
|----------------------------------|------------------------------|
| 1. Type designation and quantity | SACO 16D3, 5 pieces |
| 2. Order number | RS 811 163-AA |
| 3. Auxiliary voltage | $U_{aux} = 110 \text{ V dc}$ |
| 4. Accessories | - |
| 5. Special requirements | - |

Order numbers

| | |
|---|--|
| Annunciator unit SACO 16D3 | RS 811 163-AA, -BA |
| The last two letters of the order number indicate the auxiliary voltage U_{aux} of the annunciator unit as follows: | AA equals $U_{aux} = 80 \dots 265 \text{ V ac/dc}$ |
| | BA equals $U_{aux} = 18 \dots 80 \text{ V dc}$ |

References**Additional information**

| | |
|--|--------------------|
| Colour brochure "Annunciator unit SACO 16D1 and SACO 16D3" | 1MRS 750230-MDS EN |
| User's manual "Annunciator unit SACO 16D3" | 1MRS751354-MUM |



ABB Oy
Distribution Automation
P.O. Box 699
FI-65101 Vaasa, FINLAND
Tel +358 10 22 11
Fax +358 10 224 1094
www.abb.com/substationautomation