

RADEX®-NC

Servo lamina couplings

Technical description

RADEX®-NC is a line specifically developed for servo technology. In this coupling a set of torsionally rigid steel laminae that are soft in bending ensures a reliable compensation for axial, angular and radial shaft displacements. As an all-metal coupling - the laminae are made of stainless steel - RADEX®-NC can even be used with high temperatures (up to 200 °C) and under aggressive ambient conditions. The RADEX®-NC is manufactured in 7 sizes from size 5 to 42 for max. torques of up to 360 Nm. The hubs are designed as frictionally engaged clamping hubs made of aluminium (size 42 made of steel) and are thus backlash-free even in a reversing drive.



A typical application of the RADEX®-NC are backlash-free worm gear pairs with low transmissions. The rigidity of the coupling must be converted by reason of the transmission of the gearbox from the drive side to the driven side. Here the transmission itself has a decisive influence because it is squarely included in the calculation. This converted rigidity is added in line to the gearbox stiffness in order to get the total rigidity. In case of transmissions that are smaller than $i = 8$ we recommend to use the RADEX®-NC due to the loss of rigidity of the total system arising if flexible couplings are used.

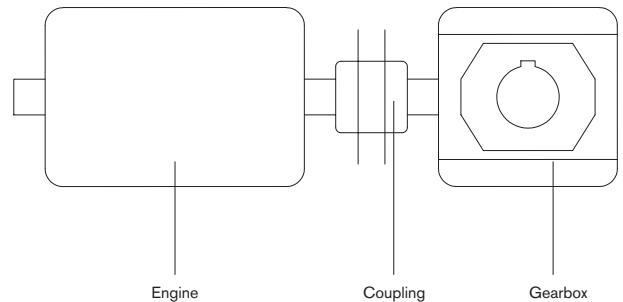

Use in explosive applications

RADEX®-NC couplings are suitable for power transmission in drives in hazardous areas. The couplings are certified and confirmed according to EC standard 94/9/EC (ATEX 95) as units of category 2G/2D and thus suitable for the use in hazardous areas of zone 1, 2, 21 and 22. Please read through our information included in the respective Type Examination Certificate and the operating and mounting instructions at www.ktr.com. Selection:

If used in hazardous areas the clamping ring hubs (clamping hubs without feather keyway only for use in category 3 (with feather keyway for cat. 2) must be selected such that there is a minimum safety factor of $s = 2$ between the peak torque (including all operating parameters) and the nominal torque and frictional torque of engagement of the coupling.



Hub types



Type 2.5 Clamping hub double slot, without feather keyway
Frictionally engaged, backlash-free shaft-hub-connection.
Transmittable torques depending on bore diameter



Type 2.6 Clamping hub double slot, with feather keyway
Positive locking power transmission with additional frictionally engaged condition. The frictionally engaged condition prevents or reduces reverse backlash, respectively. Surface pressure of the keyway connection is reduced.

RADEX®-NC DK and EK Servo lamina couplings

Double- and single-cardanic types



For legend of pictogram please refer to flapper on the cover

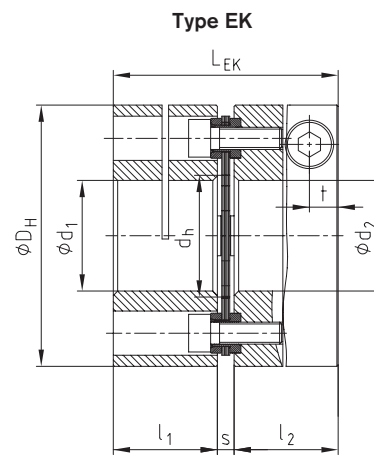
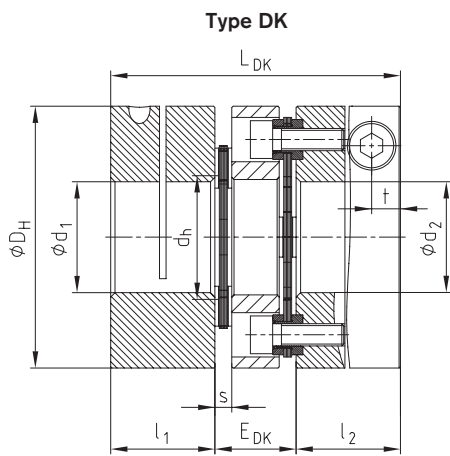
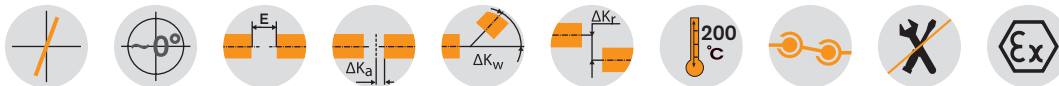

RADEX®-NC Types DK and EK Hub and spacer material aluminium (size 42 steel)/lamina stainless steel													
Size	Dimensions [mm]									Clamping screw		Mass moments of inertia	
	max. d ₁ /d ₂	D _H	l ₁ /l ₂	L _{DK}	E _{DK}	L _{EK}	d _h	s	t	M	T _A [Nm]	DK [kgm ²]	EK [kgm ²]
5	12	26	12	34	10	26,5	12	2,5	3,5	M2,5	0,8	0,000004	0,000003
10	15	35	16	44	12	35	14,5	3	5,0	M4	3	0,000016	0,000012
15	20	47	21	55	13	45	19,5	3	6,8	M6	10	0,000065	0,000053
20	25	59	24	67	19	52	24	4	6,5	M6	10	0,000199	0,000154
25	35	70	32	88	24	69	30	5	9,0	M8	25	0,000508	0,000393
35	42	84	35	98	28	77	38	7	10,5	M10	49	0,001153	0,000911
42	55	104	40	116	36	91	48	11	10,5	M10	69	0,007458	0,006153

Technical data												
Size	TKN ¹⁾ [Nm]	TK max ¹⁾ [Nm]	Max. speed [rpm]	Torsion spring stiffness [Nm/rad]		Displacement type DK			Displacement type EK			
				Type EK	Type DK	Radial [mm]	Axial [mm]	Angular [°]	Radial [mm]	Axial [mm]	Angular [°]	
5	2,5	5	25000	2400	1200	0,10	0,4	1	—	0,2	1	
10	7,5	15	20000	5600	2800	0,14	0,8	1	—	0,4	1	
15	20	40	16000	12000	6000	0,16	1,0	1	—	0,5	1	
20	30	60	12000	30000	15000	0,25	1,2	1	—	0,6	1	
25	60	120	10000	60000	30000	0,30	1,6	1	—	0,8	1	
35	100	200	9000	72000	36000	0,40	2,0	1	—	1,0	1	
42	300	600	7000	240000	120000	0,50	2,8	1	—	1,4	1	

¹⁾ See page 18 et seqq.

Review of shaft-hub-connection: Friction torques for hub type 2.5																						
Size	Pilot bored	Ø3	Ø5	Ø8	Ø10	Ø12	Ø14	Ø15	Ø16	Ø19	Ø20	Ø24	Ø25	Ø28	Ø30	Ø32	Ø35	Ø38	Ø40	Ø45	Ø50	Ø55
5	2,5	2,2	2,3	2,4	2,5																	
10	4,5		8	9	10	10	11	11														
15	5,5				28	30	31	32	32	34	35											
20	7,5					36	37	38	39	40	41	44	45									
25	9,5							82	83	87	88	93	94	98	100	103	106					
35	11,5									155	157	165	167	173	177	181	187	193	197			
42	15,0											285	287	296	301	307	315	323	329	343	357	370

Ordering-example:	RADEX®-NC 20	DK	2.5	Ø20	2.5	Ø25
	Coupling size	Type	Hub type	Finish bore	Hub type	Finish bore