

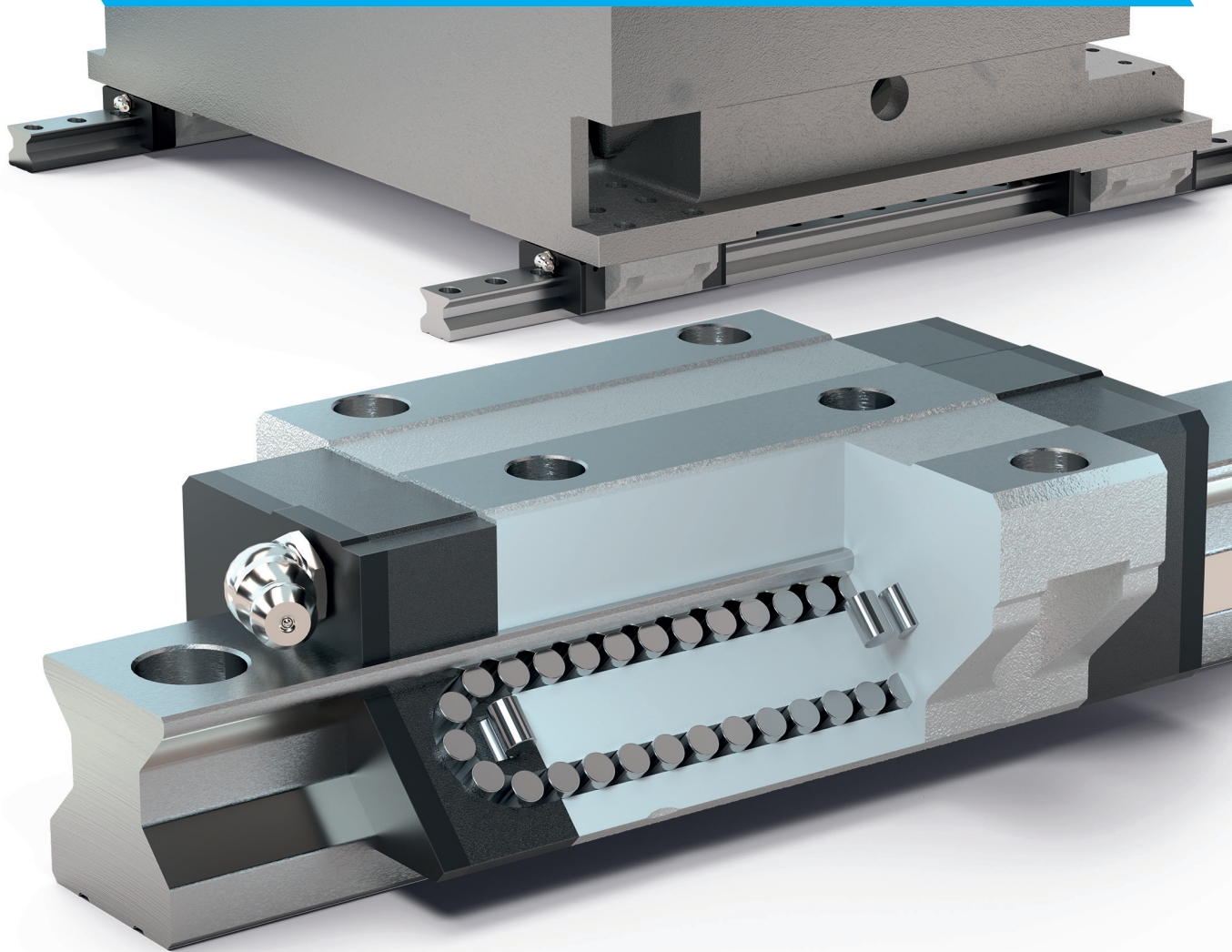

**Dr. TRETTER®**  
*BEWEGUNG IN PERFEKTION*



MOTION & CONTROL™  
**NSK**

**NSK-SCHIENENFÜHRUNGEN**  
NSK-LINEAR GUIDES



**BESTE QUALITÄT**  
BEST QUALITY



**HOCHBELASTBAR**  
HIGH LOAD CAPACITY



**PRÄZISE**  
PRECISE

Führungswagen der Bauart EMZ und GMZ  
Carriage type EMZ and GMZ

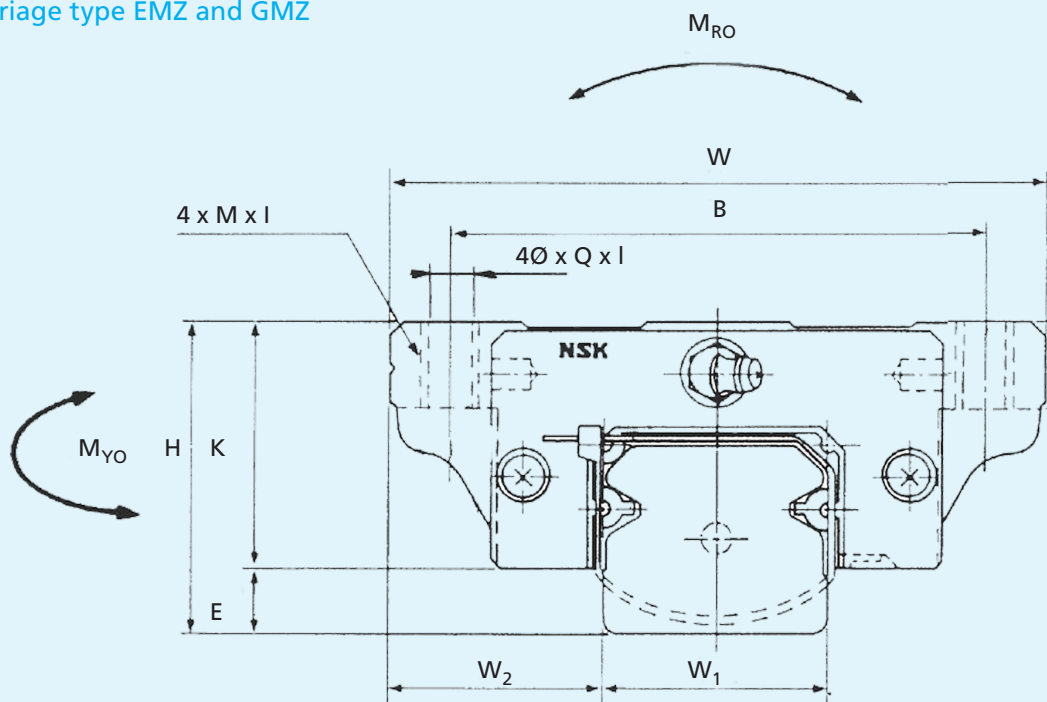

**i** Der Führungswagen kann von oben mit Schrauben des Gewindes M oder von unten mit Durchgangsschrauben kleiner Kerndurchmesser Q befestigt werden.  
The carriage can be fixed from above with screws of thread M or from below with through bolts smaller than core diameter Q.

Bestellzeichen order references	Einbaumaß installation dimensions [mm]			Wagenabmessungen carriage dimensions [mm]							M x Steigung x l M x pitch x l	
	H	E	W <sub>2</sub>	W	B x J	L	L <sub>1</sub>	J <sub>1</sub>	K	Q x l		
NAH15	EMZ	24	4,6	16,0	47	38 x 30	55,0	39	4,5	19,4	4,2 x 7	M 5 x 0,80 x 7,0
	GMZ						74,0	58	14,0		4,2 x 7	M 5 x 0,80 x 7,0
NAH20	EMZ	30	5,0	21,5	63	53 x 40	69,8	50	5,0	25,0	5,3 x 9,5	M 6 x 1,00 x 9,5
	GMZ						91,8	72	16,0		5,3 x 9,5	M 6 x 1,00 x 9,5
NAH25	EMZ	36	7,0	23,5	70	57 x 45	79,0	58	6,5	29,0	6,8 x 10	M 8 x 1,25 x 10,0
	GMZ						107,0	86	20,5		6,8 x 10	M 8 x 1,25 x 10,0
NAH30	EMZ	42	9,0	31,0	90	72 x 52	98,6	72	10,0	33,0	8,5 x 12	M 10 x 1,50 x 12,0
	GMZ						124,6	98	23,0		8,5 x 12	M 10 x 1,50 x 12,0
NAH35	EMZ	48	9,5	33,0	100	82 x 62	109,0	80	9,0	38,5	8,6 x 13	M 10 x 1,50 x 13,0
	GMZ						143,0	114	26,0		8,6 x 13	M 10 x 1,50 x 13,0
NAH45	EMZ	60	14,0	37,5	120	100 x 80	139,0	105	12,5	46,0	10,5 x 15	M 12 x 1,75 x 15,0
	GMZ						171,0	137	28,5		10,5 x 15	M 12 x 1,75 x 15,0
NAH55	EMZ	70	15,0	43,5	140	116 x 95	163,0	126	15,5	55,0	12,5 x 18	M 14 x 2,00 x 18,0
	GMZ						201,0	164	34,5		12,5 x 18	M 14 x 2,00 x 18,0
NAH65	EMZ	90	16,0	53,5	170	142 x 110	193,0	147	18,5	74,0	14,6 x 24	M 16 x 2,00 x 24,0
	GMZ						253,0	207	48,5		14,6 x 24	M 16 x 2,00 x 24,0

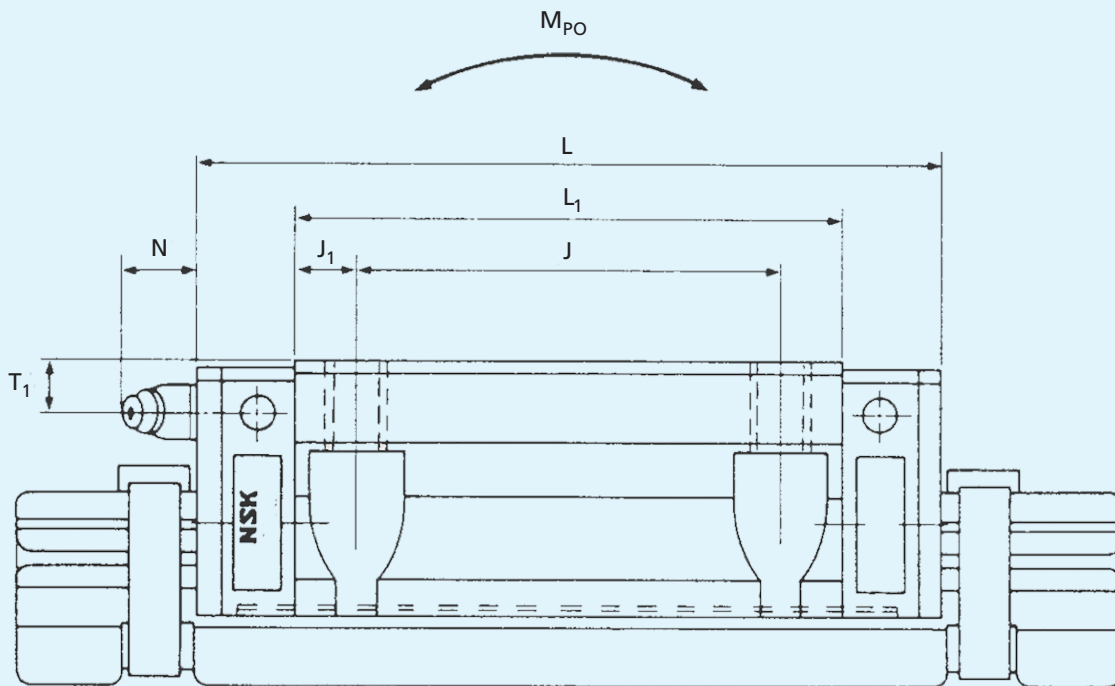

**i** Führungswagen auf Montageschiene dargestellt, Abmessungen Führungsschiene siehe Seite 40  
 Carriage shown on mounting rail, dimensions of guide rail see page 40

Schmieranschluss grease fitting [mm]	Tragzahlen load capacity [N]		zul. stat. Kippmoment allowable static moment [Nm]			Gewicht weight [kg]	Bestellzeichen order references			
	T <sub>1</sub>	N	dyn. C	stat. C <sub>o</sub>	M <sub>RO</sub>				M <sub>PO</sub>	M <sub>YO</sub>
Ø 3mm	4,6	3,3	14200	20700	108	95	80	0,17	NAH15	EMZ
			18100	32000	166	216	181	0,25		GMZ
M 6 x 0,75	5,0	11,0	23700	32500	219	185	155	0,45	NAH20	EMZ
			30000	50500	340	420	355	0,65		GMZ
M 6 x 0,75	6,0	11,0	33500	46000	360	320	267	0,63	NAH25	EMZ
			45500	71000	555	725	610	0,93		GMZ
M 6 x 0,75	7,0	11,0	47000	63000	490	350	292	1,20	NAH30	EMZ
			61000	91500	870	1030	865	1,60		GMZ
M 6 x 0,75	8,0	11,0	62500	80500	950	755	630	1,70	NAH35	EMZ
			81000	117000	1380	1530	1280	2,40		GMZ
R 1/8 ..	10,0	13,0	107000	140000	2140	1740	1460	3,00	NAH45	EMZ
			131000	187000	2860	3000	2520	3,90		GMZ
R 1/8 ..	11,0	13,0	158000	198000	3600	3000	2510	5,00	NAH55	EMZ
			193000	264000	4850	5150	4350	6,50		GMZ
R 1/8 ..	19,0	13,0	239000	281000	6150	4950	4150	10,00	NAH65	EMZ
			310000	410000	8950	10100	8450	14,10		GMZ

