

Air Slide Table

Series MXS

ø6, ø8, ø12, ø16, ø20, ø25

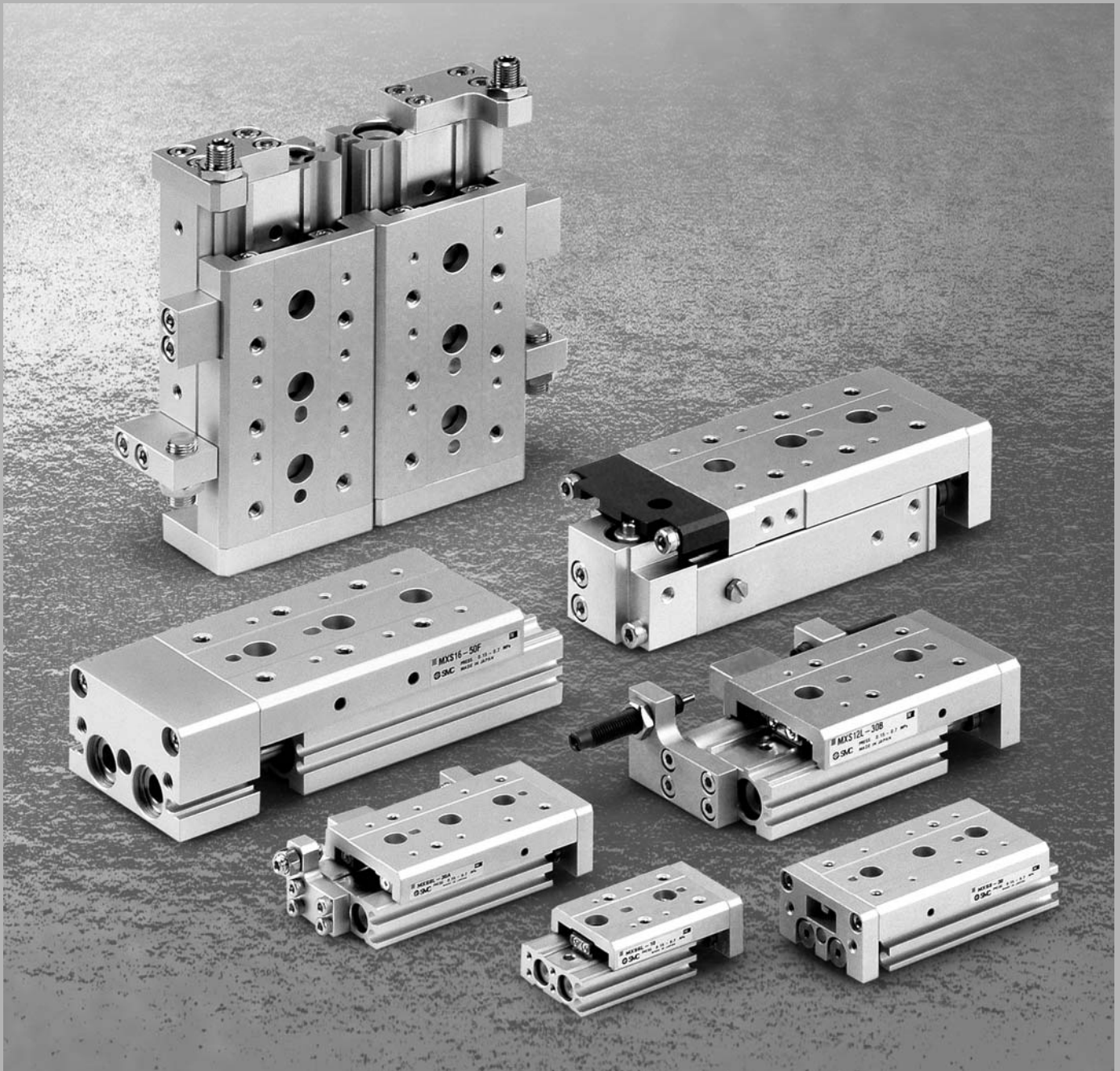

Work table and air cylinder are compactly integrated.

MXH

MXU

MXS

MXQ

MXF

MXW

MXJ

MXP

MXY

MTS

D-□

-X□

Individual
-X□

Table Deflection (Reference Values)

Table displacement due to pitch moment load

Table displacement when loads are applied to the section marked with the arrow at the full stroke.

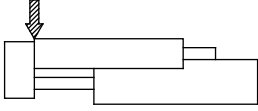

ø6

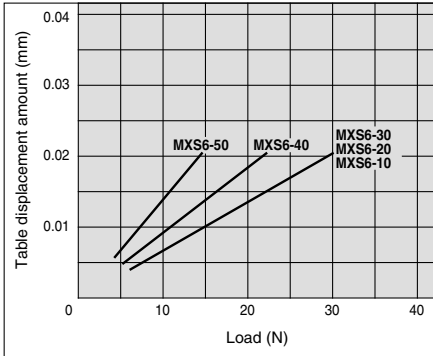

ø8

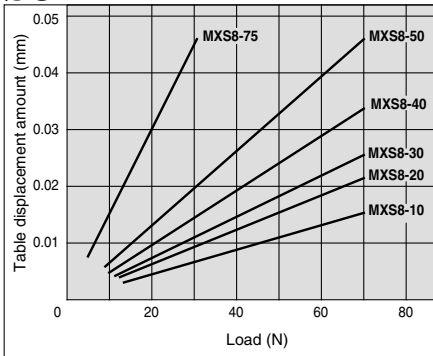

ø12

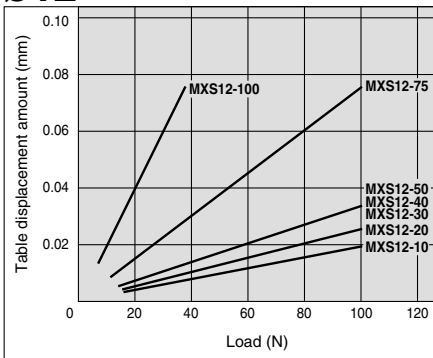
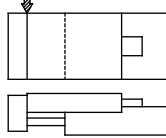
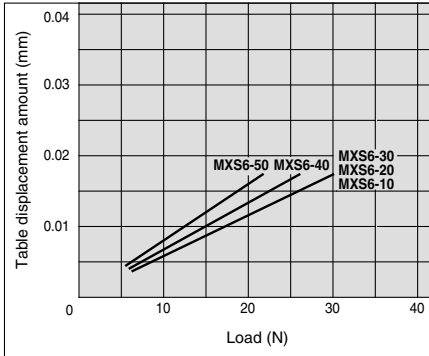

Table displacement due to yaw moment load

Table displacement when loads are applied to the section marked with the arrow at the full stroke.



ø6



ø8

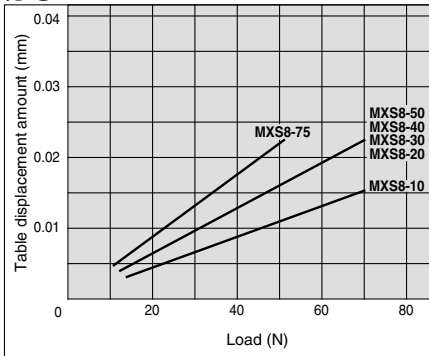

ø12

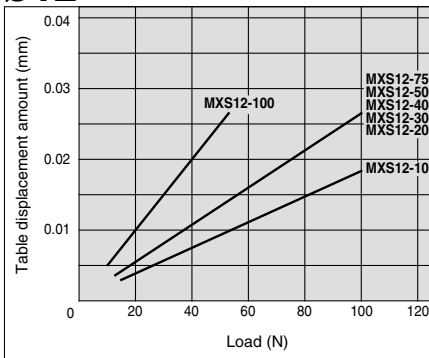
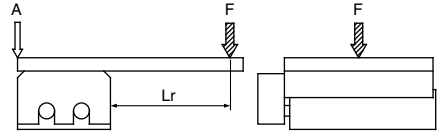
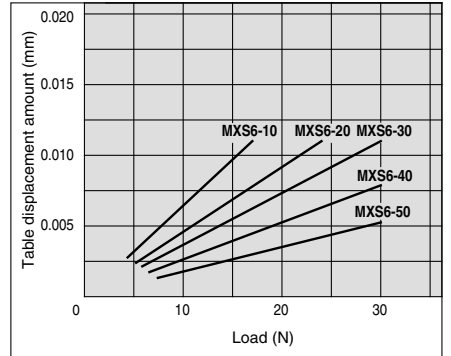

Table displacement due to roll moment load

Table displacement of section A when loads are applied to the section F with the slide table retracted.



ø6



ø8

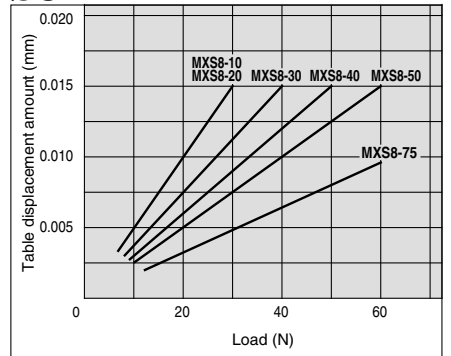

ø12

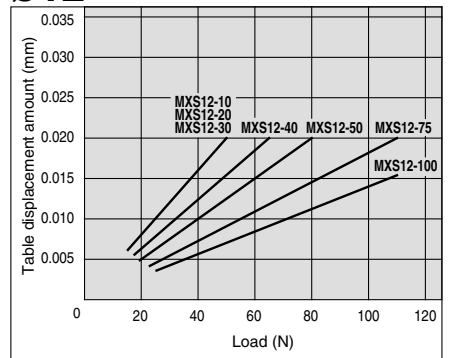

Series MXS

Dimensions: MXS12

Basic style

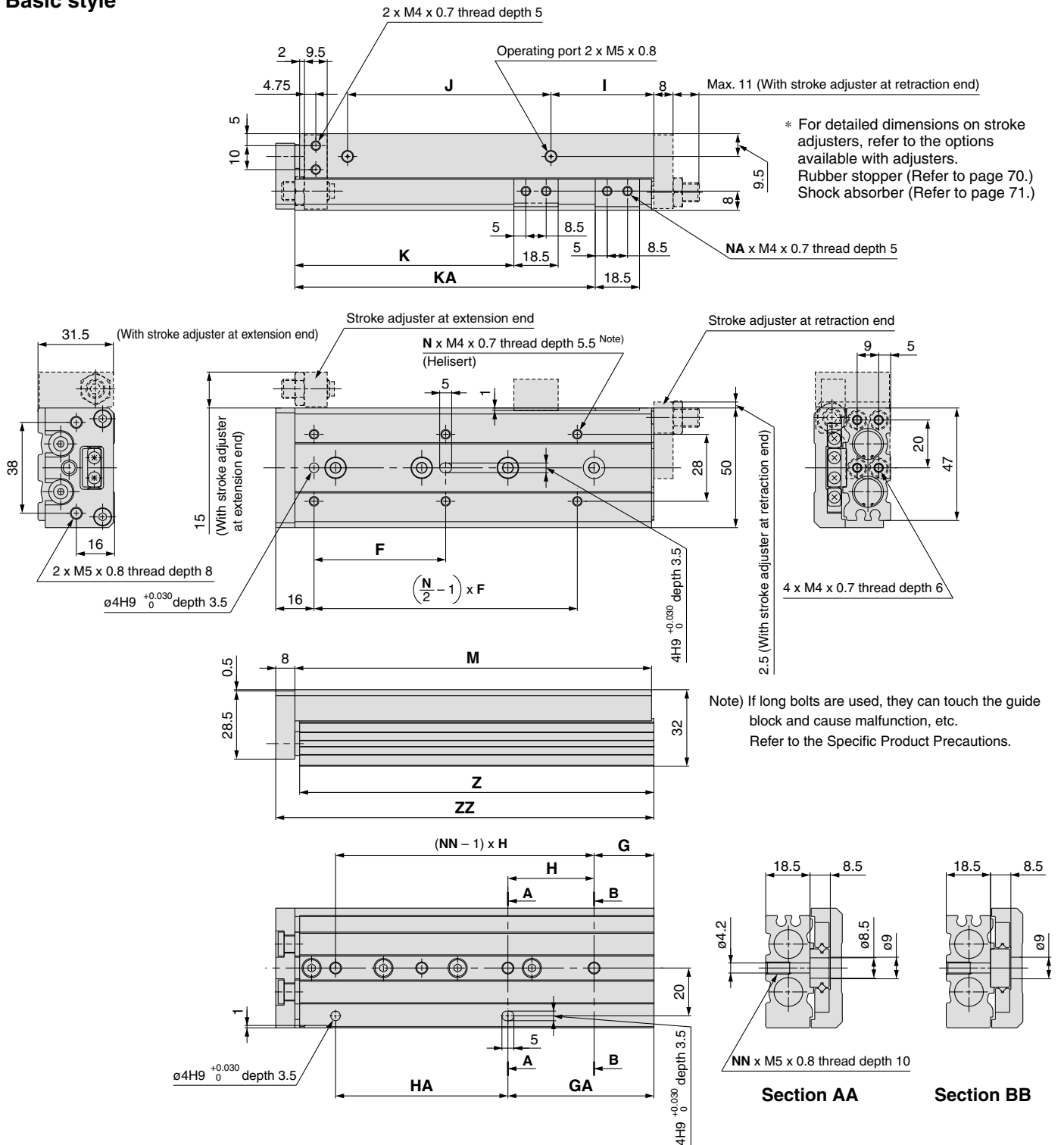

(mm)

Model	F	N	G	H	NN	GA	HA	I	J	K	KA	NA	M	Z	ZZ
MXS12-10	35	4	15	40	2	15	40	10	40	26.5	—	2	71	70	80
MXS12-20	35	4	15	40	2	15	40	10	40	36.5	—	2	71	70	80
MXS12-30	35	4	15	40	2	15	40	10	40	46.5	—	2	71	70	80
MXS12-40	50	4	17	25	3	42	25	10	52	56.5	—	2	83	82	92
MXS12-50	35	6	15	36	3	51	36	22	60	66.5	—	2	103	102	112
MXS12-75	55	6	25	36	4	61	72	43	85	91.5	125.5	4	149	148	158
MXS12-100	65	6	35	38	5	111	76	52	130	116.5	179.5	4	203	202	212

With shock absorber (ø12) MXS12-□□BS/BT/B

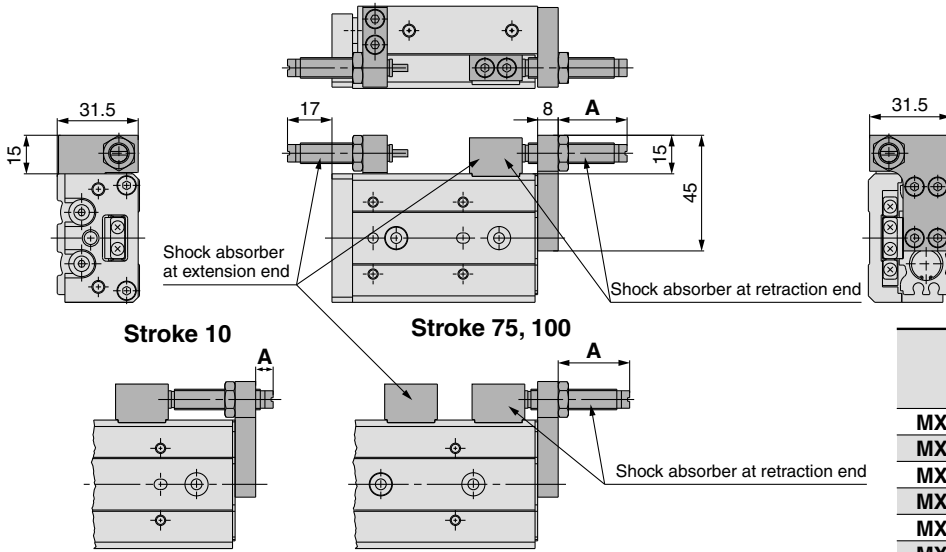

Model	Stroke adjustment range		A dimension (Retracted side mounting)
	Extension end	Retraction end	
MXS12-10	Maximum 20	2	7
MXS12-20		5	17
MXS12-30		15	27
MXS12-40		15	25
MXS12-50		5	15
MXS12-75		15	28
MXS12-100	15	28	

* Other dimensions are the same as the basic style.

With end lock (ø12) MXS12-□□R

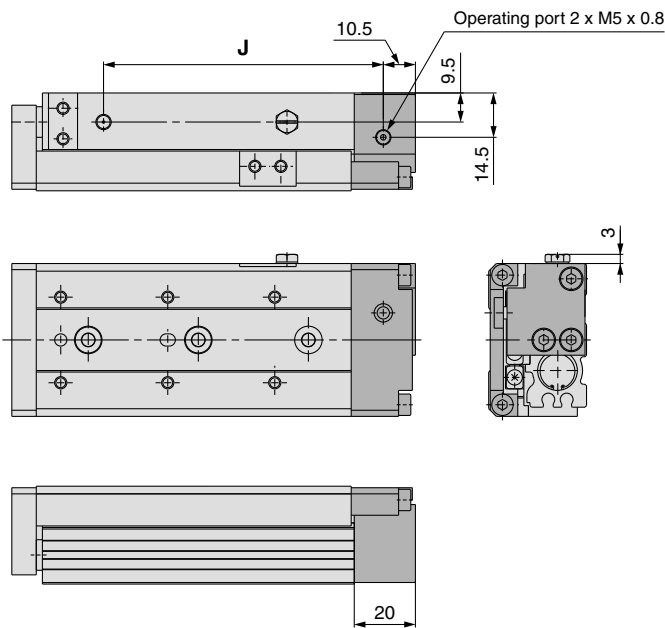

Model	J (mm)
MXS12-10R	59.5
MXS12-20R	59.5
MXS12-30R	59.5
MXS12-40R	71.5
MXS12-50R	91.5
MXS12-75R	137.5
MXS12-100R	191.5

* Other dimensions are the same as the basic style.

With buffer (ø12) MXS12-□□F

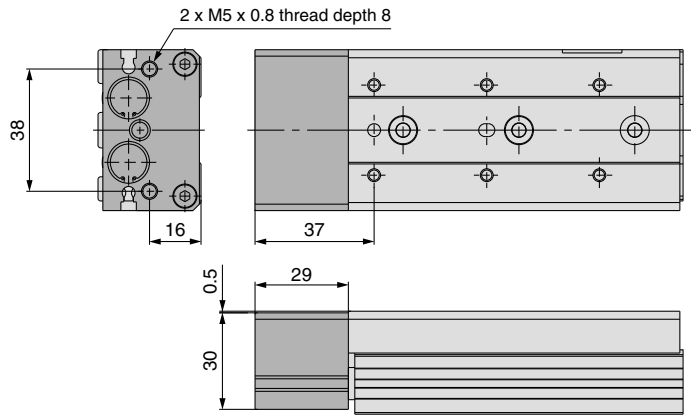

* Other dimensions are the same as the basic style.

Axial piping type (ø12) MXS12-□□P

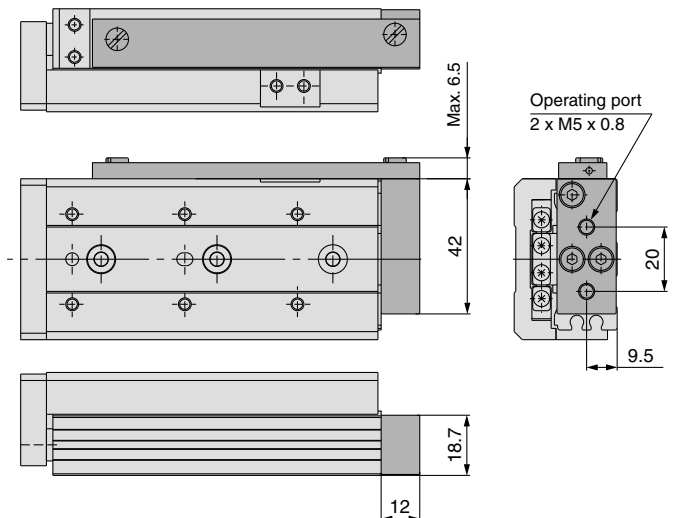

* Other dimensions are the same as the basic style.

- MXH
- MXU
- MXS**
- MXQ
- MXF
- MXW
- MXJ
- MXP
- MXY
- MTS

- D-□
- X□
- Individual
- X□