

MTL5500

I/O MODULES

by application

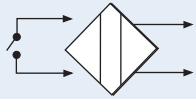

DIGITAL INPUT

Part Number	Functions
MTL5501-SR	1ch DI failsafe solid-state output + LFD alarm
MTL5510	4ch DI solid-state output
MTL5510B	4ch DI multifunction solid-state output
MTL5511	1ch DI relay output
MTL5513	2ch DI solid-state output
MTL5514	1ch DI relay output + LFD alarm
MTL5516C	2ch DI with changeover relay output
MTL5517	2ch DI relay output + LFD alarm

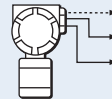

ANALOGUE INPUT

Part Number	Functions
MTL5541	1ch 2/3 wire Tx repeater
MTL5541A	1ch 2/3 wire Tx repeater, passive input
MTL5541AS	1ch 2/3 wire Tx repeater, passive input, current sink
MTL5544	2ch 2/3 wire Tx repeater
MTL5544A	2ch 2/3 wire Tx repeater, passive input
MTL5544AS	2ch 2/3 wire Tx repeater, passive input, current sink

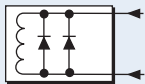

DIGITAL OUTPUT

Part Number	Functions
MTL5521	Loop powered solenoid driver, IIC
MTL5522	Loop powered solenoid driver, IIB
MTL5523	Solenoid driver with LFD
MTL5524	Switch operated solenoid driver
MTL5525	Switch operated solenoid driver low power
MTL5526	2ch switch operated relay

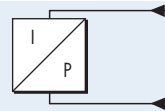

ANALOGUE OUTPUT

Part Number	Functions
MTL5546	1ch 4-20mA smart isolating driver + LFD
MTL5546Y	1ch 4-20mA smart isolating driver + oc LFD
MTL5549	2ch 4-20mA smart isolating driver + LFD
MTL5549Y	2ch 4-20mA smart isolating driver + oc LFD

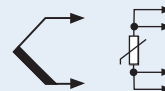

TEMPERATURE INPUT

Part Number	Functions
MTL5575	Temperature converter

GENERAL

Part Number	Functions
MTL5599	Dummy isolator



MTL5501-SR FAILSAFE SWITCH/PROXIMITY DETECTOR INTERFACE

with LFD

With the MTL5501-SR, a fail-safe switch/proximity detector located in the hazardous area can control an isolated fail-safe electronic output. The MTL5501-SR units provide line fault detection alarm contacts. The MTL5501-SR is for use with approved fail-safe sensors.

SPECIFICATION

See also common specification

Number of channels

One

Location of switches

Zone 0, IIC, T6 hazardous area
Div. 1, Group A hazardous location

Location of proximity detector

Zone 0, IIC, T4-6, hazardous location
Div 1, Group A, hazardous location

Voltage applied to sensor

8.6V dc max from 1k Ω

Input/output characteristics

Input value in sensor circuits	Fail-safe output	Operation	LFD contacts
$2.9\text{mA} < I_s < 3.9\text{mA}$	ON	Normal	CLOSED
$I_s < 1.9\text{mA} \ \& \ I_s > 5.1\text{mA}$	OFF	Normal	CLOSED
$I_s < 50\mu\text{A}$	OFF	Broken line	OPEN
$R_s < 100\Omega$	OFF	Shorted line	OPEN

Note: I_s = sensor current

Fail-safe electronic output

Output on: 24V nominal
Output off: 0V dc, max < 5V dc
Load: 750 Ω to 10k Ω
Maximum on-state current: 25mA (at 750 Ω)
Short-circuit current: 30mA

Line fault detection (LFD)

LFD relay output: contacts open when line fault detected
Switch characteristics: 0.3A 110V ac/dc; 1A 35V dc; 30W/33VA

LED indicators

Yellow: one provided for output status, ON when fail-safe output is energised
Green: one provided for power indication
Red: one provided for LFD, flashing when line fault is detected

Power requirements, V_s

@ Supply voltage	750 Ω load	typ. load
20V dc	100mA	70mA
24V dc	90mA	60mA
35V dc	65mA	45mA

Power dissipation within unit

@ Supply voltage	750 Ω load	typ. load
20V dc	1232mW	1160mW
24V dc	1392mW	1200mW
35V dc	1507mW	1335mW

Safety description

$U_o = \pm 9.7\text{V}$, $I_o = 30\text{mA}$, $P_o = 0.07\text{W}$, $C_i = 0\text{nF}$, $L_i = 0\text{mH}$
 $U_m = 253\text{V}$

Note: switch-type sensors must be fitted with resistors as shown

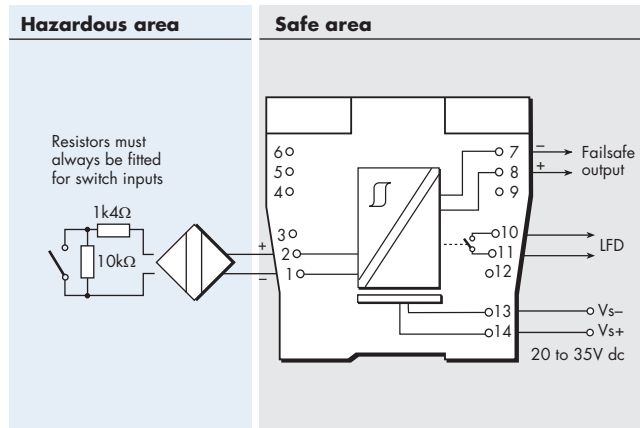

Terminal	Function
1	Input -ve
2	Input +ve
7	Output -ve
8	Output +ve
10	LFD
11	LFD
13	Supply -ve
14	Supply +ve

The given data is only intended as a product description and should not be regarded as a legal warranty of properties or guarantee. In the interest of further technical developments, we reserve the right to make design changes.



EUROPE (EMEA)
AMERICAS
ASIA PACIFIC
E-mail: enquiry@mtl-inst.com

Tel: +44 (0)1582 723633
Tel: +1 281 571 8065
Tel: +65 6 487 7887

Fax: +44 (0)1582 422283
Fax: +1 281 571 8069
Fax: +65 6 487 7997

Web site: www.mtl-inst.com

MTL5510 SWITCH/ PROXIMITY DETECTOR INTERFACE

four-channel, digital input

The MTL5510 enables four solid-state outputs in the safe area to be controlled by up to four switches or proximity detectors located in a hazardous area. Each pair of output transistors shares a common terminal and can switch +ve or -ve polarity signals. A range of module configurations is available (see Table 1) through the use of selector switches. When proximity detector modes are selected, LFD is enabled and the output switches to OFF if a line fault is detected.

SPECIFICATION

See also common specification

Number of channels

4, configured by switches

Location of switches

Zone 0, IIC, T6 hazardous area
Div 1, Group A hazardous location

Location of proximity detectors

Zone 0, IIC, T4-6 hazardous area if suitably certified
Div 1, Group A, hazardous location

Hazardous-area inputs

Inputs conforming to BS EN60947-5-6:2001 standards for proximity detectors (NAMUR)

Voltage applied to sensor

7 to 9V dc from 1k Ω \pm 10%

Input/output characteristics

Normal phase

Outputs closed if input > 2.1mA (< 2k Ω in input circuit)

Outputs open if input < 1.2mA (> 10k Ω in input circuit)

Hysteresis: 200 μ A (650 Ω) nominal

Line fault detection (LFD) (when selected)

User-selectable via switches on the side of the unit.

Open-circuit alarm on if I_{in} < 50 μ A

Open-circuit alarm off if I_{in} > 250 μ A

Short-circuit alarm on if R_{in} < 100 Ω

Short-circuit alarm off if R_{in} > 360 Ω

Note: Resistors must be fitted when using the LFD facility with a contact input

500 Ω to 1k Ω in series with switch

20k Ω to 25k Ω in parallel with switch

Safe-area outputs

Floating solid-state outputs compatible with logic circuits

Operating frequency: dc to 500Hz

Max. off-state voltage: \pm 35V

Max. off-state leakage current: \pm 50 μ A

Max. on-state resistance: 25 Ω

Max. on-state current: \pm 50mA

LED indicators

Green: power indication

Yellow: four: indicates output active

Red: indicates line fault + faulty channel's yellow LED flashes

Maximum current consumption

40mA at 24V (with all output channels energised)

Power dissipation within unit

0.96W at 24V, with 10mA loads

Safety description (each channel)

V_o = 10.5V I_o = 14mA P_o = 37mW U_m = 253V rms or dc

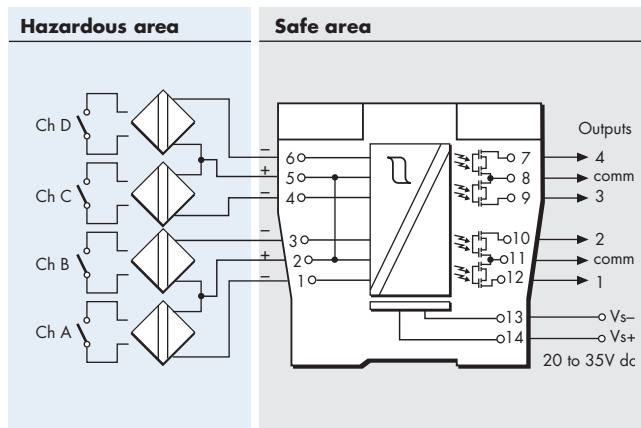

Terminal	Function
1	Input channel A
2	Input channel AB common (+)
3	Input channel B
4	Input channel C
5	Input channel CD common (+)
6	Input channel D
7	Output channel 4
8	Output channel 3/4 common
9	Output channel 3
10	Output channel 2
11	Output channel 1/2 common
12	Output channel 1
13	Supply -ve
14	Supply +ve

Table 1 - Mode options

MODE	o/p 1	o/p 2	o/p 3	o/p 4	i/p type
0	chA	chB	chC	chD	switch
1	chA rev.	chB	chC	chD	
2	chA	chB rev.	chC	chD	
3	chA	chB	chC rev.	chD	
4	chA	chB	chC	chD rev.	
5	chA rev.	chB	chC rev.	chD	
6	chA	chB rev.	chC	chD rev.	
7	chA rev.	chB rev.	chC rev.	chD rev.	prox. detector + LFD
8	chA	chB	chC	chD	
9	chA rev.	chB	chC	chD	
10	chA	chB rev.	chC	chD	
11	chA	chB	chC rev.	chD	
12	chA	chB	chC	chD rev.	
13	chA rev.	chB	chC rev.	chD	
14	chA	chB rev.	chC	chD rev.	
15	chA rev.	chB rev.	chC rev.	chD rev.	

See Instruction Manual INM5500 for further mode information.

The given data is only intended as a product description and should not be regarded as a legal warranty of properties or guarantee. In the interest of further technical developments, we reserve the right to make design changes.



EUROPE (EMEA)
AMERICAS
ASIA PACIFIC
E-mail: enquiry@mtl-inst.com

Tel: +44 (0)1582 723633
Tel: +1 281 571 8065
Tel: +65 6 487 7887

Fax: +44 (0)1582 422283
Fax: +1 281 571 8069
Fax: +65 6 487 7997

Web site: www.mtl-inst.com

MTL5510B SWITCH/ PROXIMITY DETECTOR INTERFACE

four-channel, multi-function, digital input

The MTL5510B enables four solid-state outputs in the safe area to be controlled by up to four switches or proximity detectors located in a hazardous area. Each pair of output transistors shares a common terminal and can switch +ve or -ve polarity signals. A range of module configurations is available (see Table 1) through the use of selector switches. These include start/stop operations and pulse output modes.

SPECIFICATION

See also common specification

Number of channels

4, configured by switches

Location of switches

Zone 0, IIC, T6 hazardous area
Div 1, Group A hazardous location

Location of proximity detectors

Zone 0, IIC, T4-6 hazardous area if suitably certified
Div 1, Group A, hazardous location

Hazardous-area inputs

Inputs conforming to BS EN60947-5-6:2001 standards for proximity detectors (NAMUR)

Voltage applied to sensor

7 to 9V dc from $1k\Omega \pm 10\%$

Input/output characteristics

Normal phase

Outputs closed if input $> 2.1mA$ ($< 2k\Omega$ in input circuit)

Outputs open if input $< 1.2mA$ ($> 10k\Omega$ in input circuit)

Hysteresis: $200\mu A$ (650Ω) nominal

Line fault detection (LFD) (when selected)

User-selectable via switches on the side of the unit.

Open-circuit alarm on if $I_{in} < 50\mu A$

Open-circuit alarm off if $I_{in} > 250\mu A$

Short-circuit alarm on if $R_{in} < 100\Omega$

Short-circuit alarm off if $R_{in} > 360\Omega$

Note: Resistors must be fitted when using the LFD facility with a contact input

500Ω to $1k\Omega$ in series with switch

$20k\Omega$ to $25k\Omega$ in parallel with switch

Safe-area outputs

Floating solid-state outputs compatible with logic circuits

Operating frequency: dc to 500Hz

Max. off-state voltage: $\pm 35V$

Max. off-state leakage current: $\pm 50\mu A$

Max. on-state resistance: 25Ω

Max. on-state current: $\pm 50mA$

LED indicators

Green: power indication

Yellow: four: indicates output active

Red: LFD indication + faulty channel's yellow LED flashes

Maximum current consumption

40mA at 24V (with all output channels energised)

Power dissipation within unit

0.96W at 24V, with 10mA loads

Safety description (each channel)

$V_o=10.5V$ $I_o=14mA$ $P_o=37mW$ $U_m = 253V$ rms or dc

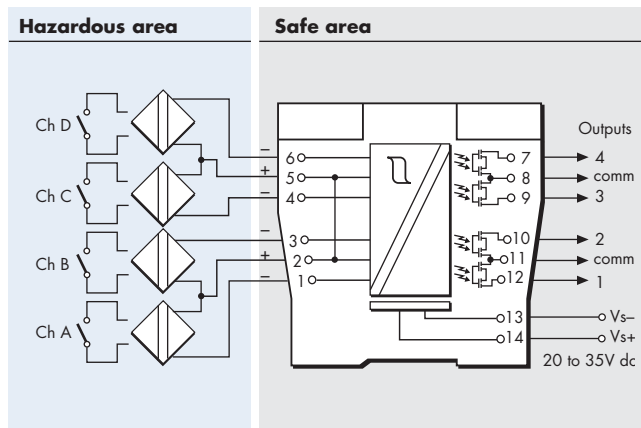

Terminal	Function
1	Input channel A
2	Input channel AB common (+)
3	Input channel B
4	Input channel C
5	Input channel CD common (+)
6	Input channel D
7	Output channel 4
8	Output channel 3/4 common
9	Output channel 3
10	Output channel 2
11	Output channel 1/2 common
12	Output channel 1
13	Supply -ve
14	Supply +ve

Table 1 - Mode options

MODE	Function	Equivalent*
0	4-ch switch input,	MTL5510
1	2-ch each channel one input, two outputs	
2	Same as mode 1 with phase reversed	
3	2-ch, 2-pole changeover output	
4	1-ch with line fault output	MTL5014
5	As mode 4 with changeover outputs	
6	1-ch with start-stop latch	MTL2210B
7	4-ch switch input,	MTL5510
8	4-ch switch input,	MTL5510
9	2-ch with line fault output	MTL5017
10	As mode 9 with LFD changeover	
11	As mode 10 with phase reversed	
12	3-ch with normally-open LFD output	
13	3-ch with normally-closed LFD output	
14	2-ch monostable, pulse stretcher	
15	4-ch switch input	MTL5510

* Note that terminal connections may not be the same on these models
See Instruction Manual INM5500 for further mode information.

The given data is only intended as a product description and should not be regarded as a legal warranty of properties or guarantee. In the interest of further technical developments, we reserve the right to make design changes.



EUROPE (EMEA)

AMERICAS

ASIA PACIFIC

E-mail: enquiry@mtl-inst.com

Tel: +44 (0)1582 723633

Tel: +1 281 571 8065

Tel: +65 6 487 7887

Web site: www.mtl-inst.com

Fax: +44 (0)1582 422283

Fax: +1 281 571 8069

Fax: +65 6 487 7997

MTL5511 SWITCH/ PROXIMITY DETECTOR INTERFACE

single channel, with line fault detection

The MTL5511 enables a safe-area load to be controlled by a switch or proximity detector located in a hazardous-area. When selected, open or short circuit conditions in the field wiring are detected by the line-fault-detect (LFD) facility and also indicated on the top of the module. Phase reversal for the channel is selected by a switch on the side of the module and output is provided by changeover relay contacts.

SPECIFICATION

See also common specification

Number of channels

One

Location of switches

Zone 0, IIC, T6 hazardous area
Div. 1, Group A hazardous location

Location of proximity detector

Zone 0, IIC, T4-6 hazardous area if suitably certified
Div. 1, Group A hazardous location

Hazardous-area inputs

Inputs conforming to BS EN60947-5-6:2001 standards for proximity detectors (NAMUR)

Voltage applied to sensor

7 to 9V dc from $1k\Omega \pm 10\%$

Input/output characteristics

Normal phase

Outputs closed if input $> 2.1mA$ ($< 2k\Omega$ in input circuit)

Outputs open if input $< 1.2mA$ ($> 10k\Omega$ in input circuit)

Hysteresis: $200\mu A$ (650Ω) nominal

Line fault detection (LFD) (when selected)

User-selectable via switches on the side of the unit. A line fault is indicated by an LED. The channel output relay is de-energised if an input line fault is detected.

Open-circuit alarm on if $I_{in} < 50\mu A$

Open-circuit alarm off if $I_{in} > 250\mu A$

Short-circuit alarm on if $R_{in} < 100\Omega$

Short-circuit alarm off if $R_{in} > 360\Omega$

Note: Resistors must be fitted when using the LFD facility with a contact input

500Ω to $1k\Omega$ in series with switch

$20k\Omega$ to $25k\Omega$ in parallel with switch

Safe-area output

Single pole relay with changeover contacts

Note: reactive loads must be adequately suppressed

Relay characteristics

Response time: 10ms maximum

Contact rating: 250V ac, 2A, $\cos\phi > 0.7$

40V dc, 2A, resistive load

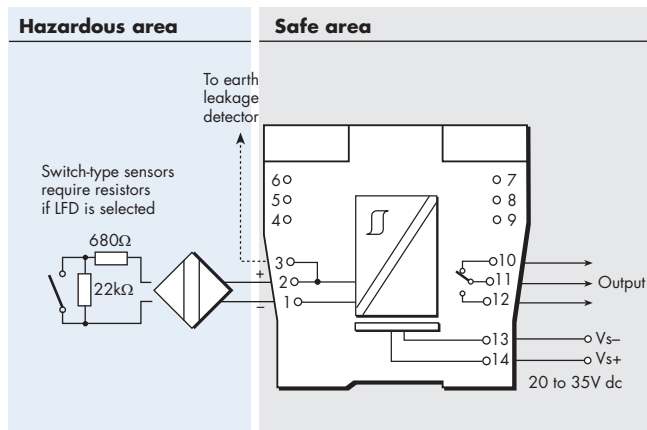

Terminal	Function
1	Input -ve
2	Input +ve
3	To earth leakage detector*
10	Output normally-closed contact
11	Common
12	Output normally-open contact
13	Supply -ve
14	Supply +ve

*Signal plug HAZ1-3 is required for access to this function

LED indicators

Green: power indication

Yellow: channel status, on when output is energised

Red: LFD indication, on when line fault is detected

Maximum current consumption

25mA at 24V

Power dissipation within unit

0.6W at 24V

Safety description (each channel)

$V_o = 10.5V$ $I_o = 14mA$ $P_o = 37mW$ $U_m = 253V$ rms or dc

The given data is only intended as a product description and should not be regarded as a legal warranty of properties or guarantee. In the interest of further technical developments, we reserve the right to make design changes.



EUROPE (EMEA)

AMERICAS

ASIA PACIFIC

E-mail: enquiry@mtl-inst.com

Tel: +44 (0)1582 723633

Tel: +1 281 571 8065

Tel: +65 6 487 7887

Web site: www.mtl-inst.com

Fax: +44 (0)1582 422283

Fax: +1 281 571 8069

Fax: +65 6 487 7997

MTL5513 SWITCH/ PROXIMITY DETECTOR INTERFACE

two-channel, with line fault detection
and phase reversal

The MTL5513 enables two solid-state outputs in the safe area to be controlled by two switches or proximity detectors located in the hazardous area. The Ch1/Ch2 output transistors share a common terminal and can switch +ve or -ve polarity signals. Independent output phase reversal and line fault detection are enabled via switches for each output. LFD indication is provided on the top of the module.

SPECIFICATION

See also common specification

Number of channels

Two

Location of switches

Zone 0, IIC, T6 hazardous area
Div. 1, Group A hazardous location

Location of proximity detectors

Zone 0, IIC, T4-6 hazardous area if suitably certified
Div. 1, Group A hazardous location

Hazardous-area inputs

Inputs conforming to BS EN60947-5-6:2001 standards for proximity detectors (NAMUR)

Voltage applied to sensor

7 to 9V dc from 1k Ω \pm 10%

Input/output characteristics

Normal phase

Outputs closed if input > 2.1mA (< 2k Ω in input circuit)

Outputs open if input < 1.2mA (> 10k Ω in input circuit)

Hysteresis: 200 μ A (650 Ω) nominal

Line fault detection (LFD) (when selected)

User-selectable for each channel via switches on the side of the unit. Line faults are indicated by an LED for each channel.

Open-circuit alarm on if $I_{in} < 50\mu$ A

Open-circuit alarm off if $I_{in} > 250\mu$ A

Short-circuit alarm on if $R_{in} < 100\Omega$

Short-circuit alarm off if $R_{in} > 360\Omega$

Note: Resistors must be fitted when using the LFD facility with a contact input
500 Ω to 1k Ω in series with switch

20k Ω to 25k Ω in parallel with switch

Phase reversal

Independent for each channel, user-selectable

Safe-area outputs

Floating solid-state outputs compatible with logic circuits

Operating frequency: dc to 500Hz

Max. off-state voltage: \pm 35V

Max. off-state leakage current: \pm 50 μ A

Max. on-state resistance: 25 Ω

Max. on-state current: \pm 50mA

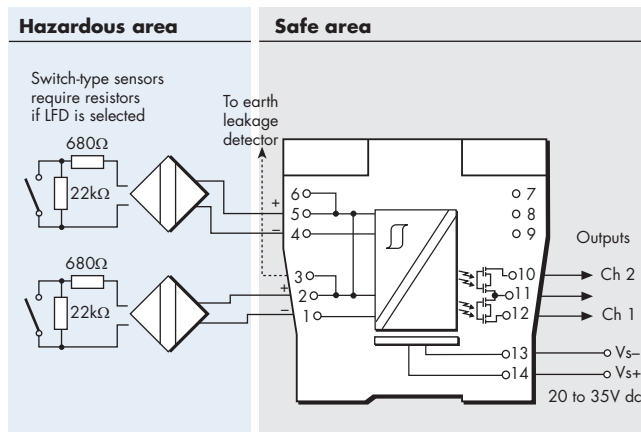

Terminal	Function
1	Input -ve (Ch 1)
2	Input +ve (Ch 1)
3	To earth leakage detector*
4	Input -ve (Ch 2)
5	Input +ve (Ch 2)
6	To earth leakage detector*
10	Output (Ch 2)
11	Output (Ch 1/Ch 2)
12	Output (Ch 1)
13	Supply -ve
14	Supply +ve

* Signal plug HAZ1-3 is required for access to this function

LED indicators

Green: power indication

Yellow: two: channel status, on when outputs are on

Red: two: LFD indication, on when line fault detected

Maximum current consumption

27mA at 24V

Power dissipation within unit

0.65W typical at 24V, with 10mA loads

0.78W max. with 50mA loads

Safety description (each channel)

$V_o = 10.5V$ $I_o = 14mA$ $P_o = 37mW$ $U_m = 253V$ rms or dc

The given data is only intended as a product description and should not be regarded as a legal warranty of properties or guarantee. In the interest of further technical developments, we reserve the right to make design changes.



EUROPE (EMEA)

AMERICAS

ASIA PACIFIC

E-mail: enquiry@mtl-inst.com

Tel: +44 (0)1582 723633

Tel: +1 281 571 8065

Tel: +65 6 487 7887

Web site: www.mtl-inst.com

Fax: +44 (0)1582 422283

Fax: +1 281 571 8069

Fax: +65 6 487 7997

MTL5514 SWITCH/ PROXIMITY DETECTOR INTERFACE

single channel with line fault detection
and phase reversal

The MTL5514 enables a safe-area load to be controlled, through a relay, by a proximity detector or switch located in a hazardous area. Line faults are signalled through a separate relay and indicated on the top of the module. Switches are provided to select phase reversal and to enable the line fault detection.

SPECIFICATION

See also common specification

Number of channels

One

Location of switch

Zone 0, IIC, T6 hazardous area
Div.1, Group A, hazardous location

Location of proximity detector

Zone 0, IIC, T4-6 hazardous area, if suitably certified
Div.1, Group A, hazardous location

Hazardous-area inputs

Inputs conforming to BS EN60947-5-6:2001 standards for proximity detectors (NAMUR)

Voltage applied to sensor

7 to 9V dc from $1k\Omega \pm 10\%$

Input/output characteristics

Normal phase

Outputs closed if input $> 2.1mA$ ($< 2k\Omega$ in input circuit)

Outputs open if input $< 1.2mA$ ($> 10k\Omega$ in input circuit)

Hysteresis: $200\mu A$ (650Ω) nominal

Line fault detection (LFD) (when selected)

User-selectable via switches on the side of the unit. Line faults are indicated by an LED. Line fault relay is energised and channel output relay de-energised if input line-fault detected

Open-circuit alarm on if $I_{in} < 50\mu A$

Open-circuit alarm off if $I_{in} > 250\mu A$

Short-circuit alarm on if $R_{in} < 100\Omega$

Short-circuit alarm off if $R_{in} > 360\Omega$

Note: Resistors must be fitted when using the LFD facility with a contact input 500Ω to $1k\Omega$ in series with switch

$20k\Omega$ to $25k\Omega$ in parallel with switch

Safe-area output

Channel: Single pole relay with changeover contacts

LFD: Single pole relay with changeover contacts

Note: reactive loads must be adequately suppressed

Relay characteristics

Response time: 10ms maximum

Contact rating: 250V ac, 2A, $\cos\phi > 0.7$

40V dc, 2A, resistive load

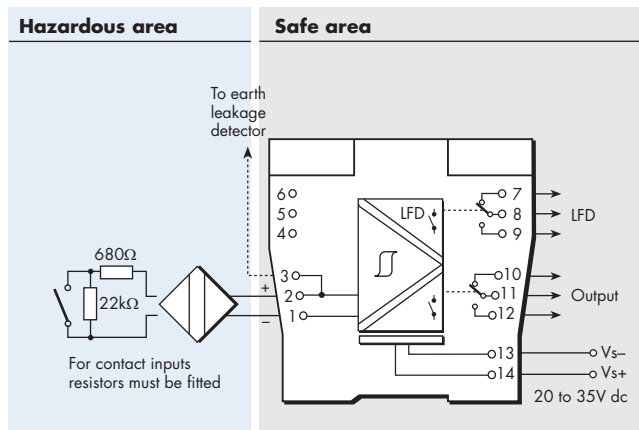

Terminal	Function
1	Input -ve
2	Input +ve
3	To earth leakage detector*
7	LFD NC contact
8	LFD Common
9	LFD NO contact
10	Output NC contact
11	Output Common
12	Output NO contact
13	Supply -ve
14	Supply +ve

*Signal plug HAZ1-3 is required for access to this function

LED indicators

Green: power indication

Yellow: channel status, on when output circuit is closed

Red: LFD indication, on when line fault is detected

Maximum current consumption

25mA at 24V dc

Power dissipation within unit

0.6W at 24V

Safety description

$V_o = 10.5V$ $I_o = 14mA$ $P_o = 37mW$ $U_m = 253V$ rms or dc

The given data is only intended as a product description and should not be regarded as a legal warranty of properties or guarantee. In the interest of further technical developments, we reserve the right to make design changes.



EUROPE (EMEA)

AMERICAS

ASIA PACIFIC

E-mail: enquiry@mtl-inst.com

Tel: +44 (0)1582 723633

Tel: +1 281 571 8065

Tel: +65 6 487 7887

Web site: www.mtl-inst.com

Fax: +44 (0)1582 422283

Fax: +1 281 571 8069

Fax: +65 6 487 7997

MTL5516C SWITCH/ PROXIMITY DETECTOR INTERFACE

two-channel, with line fault detection

The MTL5516C enables two safe-area loads to be controlled by a switch or proximity detector located in a hazardous-area. When selected, open or short circuit conditions in the field wiring are detected by the line-fault-detect (LFD) facility and also indicated on the top of the module. Phase reversal for each channel is selected by a switch on the side of the module and output is provided by changeover relay contacts.

SPECIFICATION

See also common specification

Number of channels

Two

Location of switches

Zone 0, IIC, T6 hazardous area

Div. 1, Group A hazardous location

Location of proximity detector

Zone 0, IIC, T4–6 hazardous area if suitably certified

Div. 1, Group A hazardous location

Hazardous-area inputs

Inputs conforming to BS EN60947–5–6:2001 standards for proximity detectors (NAMUR)

Voltage applied to sensor

7 to 9V dc from $1k\Omega \pm 10\%$

Input/output characteristics

Normal phase

Outputs closed if input $> 2.1mA$ ($< 2k\Omega$ in input circuit)

Outputs open if input $< 1.2mA$ ($> 10k\Omega$ in input circuit)

Hysteresis: $200\mu A$ (650Ω) nominal

Line fault detection (LFD) (when selected)

User-selectable via switches on the side of the unit. Line faults are indicated by an LED for each channel. The channel output relay is de-energised if an input line fault is detected.

Open-circuit alarm on if $I_{in} < 50\mu A$

Open-circuit alarm off if $I_{in} > 250\mu A$

Short-circuit alarm on if $R_{in} < 100\Omega$

Short-circuit alarm off if $R_{in} > 360\Omega$

Note: Resistors must be fitted when using the LFD facility with a contact input

500Ω to $1k\Omega$ in series with switch

$20k\Omega$ to $25k\Omega$ in parallel with switch

Safe-area output

Two single-pole relays with changeover contacts

Note: reactive loads must be adequately suppressed

Relay characteristics

Response time: 10ms maximum

Contact rating: 250V ac, 2A, $\cos\phi > 0.7$

40V dc, 2A, resistive load

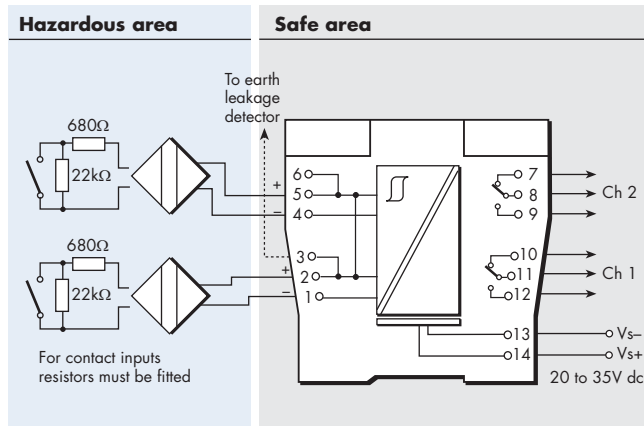

Terminal	Function
1	Input -ve (Ch 1)
2	Input +ve (Ch 1)
3	To earth leakage detector*
4	Input -ve (Ch 2)
5	Input +ve (Ch 2)
6	To earth leakage detector*
7	Normally-closed contact (Ch 2)
8	Common (Ch 2)
9	Normally-open contact (Ch 2)
10	Normally-closed contact (Ch 1)
11	Common (Ch 1)
12	Normally-open contact (Ch 1)
13	Supply -ve
14	Supply +ve

*Signal plug HAZ1-3 is required for access to this function

LED indicators

Green: power indication

Yellow: two: channel status, on when output is energised

Red: two: LFD indication, on when line fault detected

Maximum current consumption

35mA at 24V

Power dissipation within unit

0.84W at 24V

Safety description (each channel)

$V_o = 10.5V$ $I_o = 14mA$ $P_o = 37mW$ $U_m = 253V$ rms or dc

The given data is only intended as a product description and should not be regarded as a legal warranty of properties or guarantee. In the interest of further technical developments, we reserve the right to make design changes.



EUROPE (EMEA)

AMERICAS

ASIA PACIFIC

E-mail: enquiry@mtl-inst.com

Tel: +44 (0)1582 723633

Tel: +1 281 571 8065

Tel: +65 6 487 7887

Web site: www.mtl-inst.com

Fax: +44 (0)1582 422283

Fax: +1 281 571 8069

Fax: +65 6 487 7997

MTL5517 SWITCH/ PROXIMITY DETECTOR INTERFACE

two-channel with line fault detection
and phase reversal

The MTL5517 enables two safe-area loads to be controlled, through a relay, by proximity detectors or switches located in a hazardous area. Line faults are signalled through a separate relay and indicated on the top of the module. Switches are provided to select phase reversal and to enable the line fault detection.

SPECIFICATION

See also common specification

Number of channels

Two

Location of switch

Zone 0, IIC, T6 hazardous area
Div.1, Group A, hazardous location

Location of proximity detector

Zone 0, IIC, T4–6 hazardous area, if suitably certified
Div.1, Group A, hazardous location

Hazardous-area inputs

Inputs conforming to BS EN60947–5–6:2001 standards for proximity detectors (NAMUR)

Voltage applied to sensor

7 to 9V dc from $1k\Omega \pm 10\%$

Input/output characteristics

Normal phase

Outputs closed if input $> 2.1\text{mA}$ ($< 2k\Omega$ in input circuit)

Outputs open if input $< 1.2\text{mA}$ ($> 10k\Omega$ in input circuit)

Hysteresis: $200\mu\text{A}$ (650Ω) nominal

Line fault detection (LFD) (when selected)

User selectable by switches on the side of the module. Line faults are indicated by the LED for each channel.

Line fault relay is energised and channel output relay de-energised if input line-fault detected

Open-circuit alarm on if $I_{in} < 50\mu\text{A}$

Open-circuit alarm off if $I_{in} > 250\mu\text{A}$

Short-circuit alarm on if $R_{in} < 100\Omega$

Short-circuit alarm off if $R_{in} > 360\Omega$

Note: Resistors must be fitted when using the LFD facility with a contact input
 500Ω to $1k\Omega$ in series with switch

$20k\Omega$ to $25k\Omega$ in parallel with switch

Safe-area output

Channel: Two single-pole relays with normally open contacts

LFD: Single pole relay with changeover contacts

Note: reactive loads must be adequately suppressed

Relay characteristics

Response time: 10ms maximum

Contact rating: 250V ac, 2A, $\cos\phi > 0.7$

40V dc, 2A, resistive load

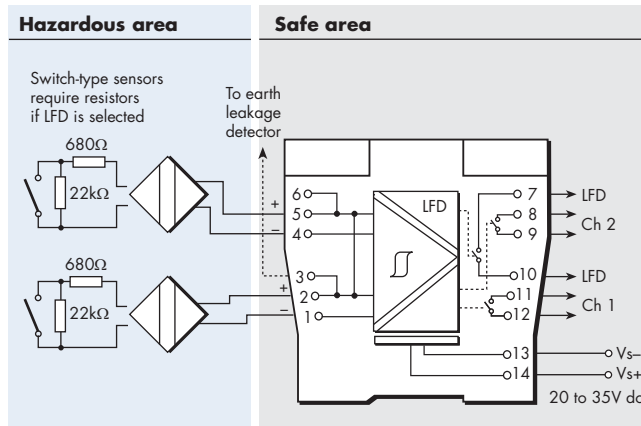

Terminal	Function
1	Input -ve (Ch 1)
2	Input +ve (Ch 1)
3	To earth leakage detector*
4	Input -ve (Ch 2)
5	Input +ve (Ch 2)
6	To earth leakage detector*
7	Line fault detection
8	Output (Ch 2)
9	Output (Ch 2)
10	Line fault detection
11	Output (Ch 1)
12	Output (Ch 1)
13	Supply -ve
14	Supply +ve

*Signal plug HAZ1-3 is required for access to this function

LED indicators

Green: power indication

Yellow: two: channel status, on when output is energised

Red: two: LFD indication, on when line fault detected

Maximum current consumption

35mA at 24V

Power dissipation within unit

0.84W at 24V

Safety description (each channel)

$V_o = 10.5\text{V}$ $I_o = 14\text{mA}$ $P_o = 37\text{mW}$ $U_m = 253\text{V rms or dc}$

The given data is only intended as a product description and should not be regarded as a legal warranty of properties or guarantee. In the interest of further technical developments, we reserve the right to make design changes.



EUROPE (EMEA)

AMERICAS

ASIA PACIFIC

E-mail: enquiry@mtl-inst.com

Tel: +44 (0)1582 723633

Tel: +1 281 571 8065

Tel: +65 6 487 7887

Web site: www.mtl-inst.com

Fax: +44 (0)1582 422283

Fax: +1 281 571 8069

Fax: +65 6 487 7997

MTL5521 SOLENOID/ ALARM DRIVER

loop-powered, IIC

The MTL5521 is a loop-powered module which enables a device located in the hazardous area to be controlled from the safe area. The MTL5521 can drive a certified intrinsically safe low-power load, as well as non-energy-storing simple apparatus such as an LED.

SPECIFICATION

See also common specification

Number of channels

One

Location of load

Zone 0, IIC, T4--6 hazardous area if suitably certified
Div. 1, Group A hazardous location

Minimum output voltage Equivalent output circuit

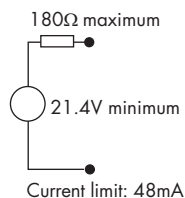
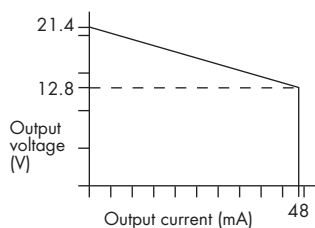

Input voltage

20 to 35V dc

Hazardous-area output

Minimum output voltage: 12.8V at 48mA
Maximum output voltage: 24V from 180Ω
Current limit: 48mA

Output ripple

< 0.5% of maximum output, peak to peak

Response time

Output within 10% of final value within 100ms

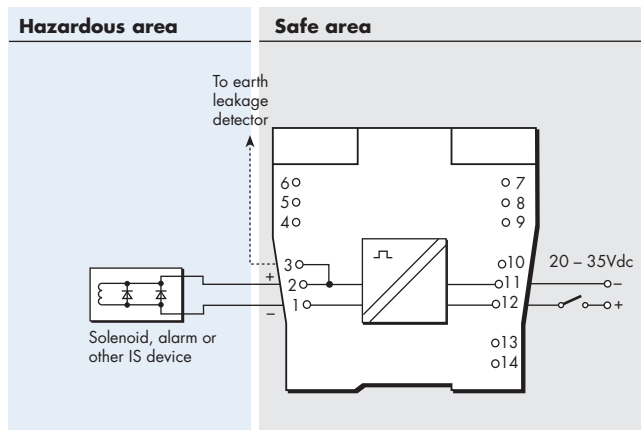

Terminal	Function
1	Output -ve
2	Output +ve
3	To earth leakage detector*
11	Supply -ve
12	Supply +ve

*Signal plug HAZ1-3 is required for access to this function

LED indicator

Yellow: output status, on when output circuit is active

Maximum current consumption

90mA at 24V

Power dissipation within unit

1.4W at 24V

Safety description

$V_o=25V$ $I_o=147mA$ $P_o=919mW$ $U_m = 253V$ rms or dc

The given data is only intended as a product description and should not be regarded as a legal warranty of properties or guarantee. In the interest of further technical developments, we reserve the right to make design changes.



EUROPE (EMEA)
AMERICAS
ASIA PACIFIC
E-mail: enquiry@mtl-inst.com

Tel: +44 (0)1582 723633
Tel: +1 281 571 8065
Tel: +65 6 487 7887

Fax: +44 (0)1582 422283
Fax: +1 281 571 8069
Fax: +65 6 487 7997

Web site: www.mtl-inst.com

MTL5522 SOLENOID/ ALARM DRIVER

loop-powered, IIB

The MTL5522 is a loop-powered module which enables a device located in the hazardous area to be controlled from the safe area. The MTL5522 can drive a certified intrinsically safe low-power load, as well as non-energy-storing simple apparatus such as an LED. The unit's input/output isolation allows the control switch to be connected into either side of the 24V dc supply circuit.

SPECIFICATION

See also common specification

Number of channels

One

Location of load

Zone 0, IIB, T4–6 hazardous area if suitably certified
Div. 1, Group C hazardous location

Minimum output voltage Equivalent output circuit

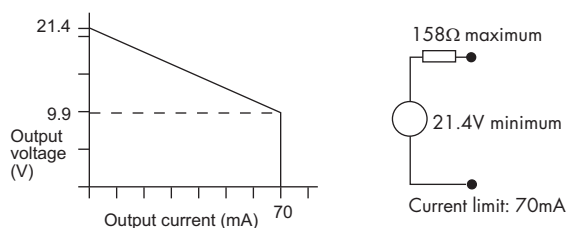

Input voltage

20 to 35V dc

Hazardous-area output

Minimum output voltage: 9.9V at 70mA
Maximum output voltage: 24V from 158Ω
Current limit: 70mA

Output ripple

< 0.5% of maximum output, peak to peak

Response time

Output within 10% of final value within 100ms

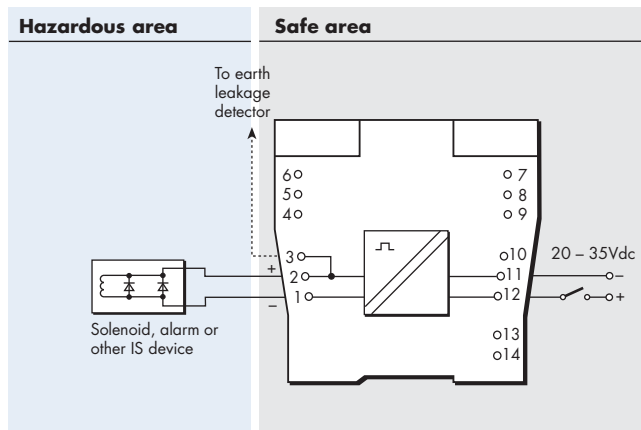

Terminal	Function
1	Output -ve
2	Output +ve
3	To earth leakage detector*
11	Supply -ve
12	Supply +ve

*Signal plug HAZ1-3 is required for access to this function

LED indicator

Yellow: output status, on when output circuit is active

Maximum current consumption

125mA (typ.) at 24V

Power dissipation within unit

1.4W at 24V

Safety description

$V_o=25V$ $I_o=166mA$ $P_o=1.04W$ $U_m=253V$ rms or dc

The given data is only intended as a product description and should not be regarded as a legal warranty of properties or guarantee. In the interest of further technical developments, we reserve the right to make design changes.



EUROPE (EMEA)

Tel: +44 (0)1582 723633

Fax: +44 (0)1582 422283

AMERICAS

Tel: +1 281 571 8065

Fax: +1 281 571 8069

ASIA PACIFIC

Tel: +65 6 487 7887

Fax: +65 6 487 7997

E-mail: enquiry@mtl-inst.com Web site: www.mtl-inst.com

MTL5523

SOLENOID/ALARM DRIVER

with line fault detection, IIC

With the MTL5523 interface, an on/off device in a hazardous area can be controlled by a voltage signal in the safe area. It is suitable for driving loads such as solenoids. Line fault detection (LFD), which operates irrespective of the output state, is signalled by a safe-area solid-state switch which de-energises MTL5523, if a field line is open or short-circuited. Earth fault detection can be provided by connecting an MTL4220 earth leakage detector to terminal 3.

SPECIFICATION

See also common specification

Number of channels

One

Location of load

Zone 0, IIC, T4–6 hazardous area if suitably certified
Div. 1, Group A, hazardous location

Minimum output voltage

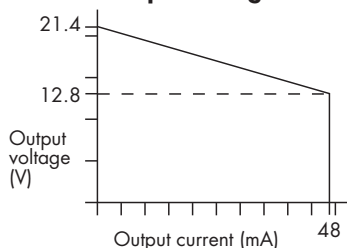

Equivalent output circuit

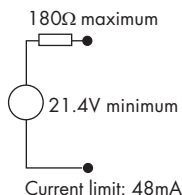

Hazardous-area output

Minimum output voltage: 12.8V at 48mA
Maximum output voltage: 24V from 180Ω
Current limit: 48mA

Output ripple

< 0.5% of maximum output, peak to peak

Control input

Suitable for switch contacts, an open collector transistor or logic drive

Output turns on if input switch closed, transistor on or < 1.4V applied across terminals 11 & 12

Output turns off if input switch open, transistor off or > 4.5V applied across terminals 11 & 12

Response time

Output within 10% of final value within 100ms

Line fault detection (LFD)

Open or short circuit in field cabling de-energises solid state line-fault signal.

LFD transistor is switched on, provided that the field circuit impedance is > 55Ω and < 6k5Ω.

Line fault signal characteristics

Maximum off-state voltage: 35V
Maximum off-state leakage current: 10μA
Maximum on-state voltage drop: 2V
Maximum on-state current: 50mA

Note: LFD signal is Zener-diode protected against inductive loads

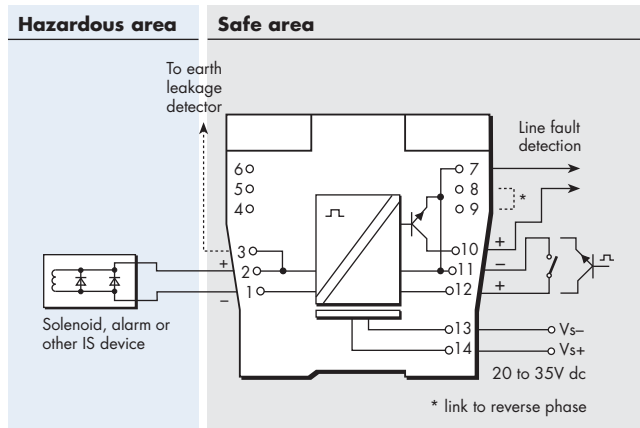

Terminal	Function
1	Output -ve
2	Output +ve
3	To earth leakage detector*
7	Line fault signal -ve
8	Phase reversal link
9	Phase reversal link
10	Line fault signal +ve
11	Control -ve
12	Control +ve
13	Supply -ve
14	Supply +ve

*Signal plug HAZ1-3 is required for access to this function

LED indicators

Green: power indication

Yellow: output status, on when output circuit is active

Red: LFD indication, on when line fault is detected

Maximum current consumption

100mA at 24V dc

Power dissipation within unit

1.2W with typical solenoid valve, output on
2.0W worst case

Safety description

$V_o=25V$ $I_o=147mA$ $P_o=919mW$ $U_m=253V$ rms or dc

The given data is only intended as a product description and should not be regarded as a legal warranty of properties or guarantee. In the interest of further technical developments, we reserve the right to make design changes.



EUROPE (EMEA)

AMERICAS

ASIA PACIFIC

E-mail: enquiry@mtl-inst.com

Tel: +44 (0)1582 723633

Tel: +1 281 571 8065

Tel: +65 6 487 7887

Web site: www.mtl-inst.com

Fax: +44 (0)1582 422283

Fax: +1 281 571 8069

Fax: +65 6 487 7997

MTL5524 SOLENOID/ ALARM DRIVER

powered, logic drive with phase reversal

The MTL5524 enables an on/off device in a hazardous area to be controlled by a volt-free contact or logic signal in the safe area. It can drive loads such as solenoids, alarms, LEDs and other low power devices that are certified as intrinsically safe or are classified as non-energy storing simple apparatus. By connecting a second safe-area switch or logic signal, the output can be disabled to permit, for example, a safety system to override a control signal.

SPECIFICATION

See also common specification

Number of channels

One

Location of load

Zone 0, IIC, T4–6 hazardous area if suitably certified
Div.1, Group A, hazardous location

Minimum output voltage

Equivalent output circuit

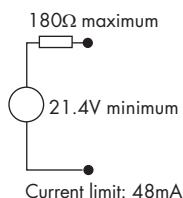
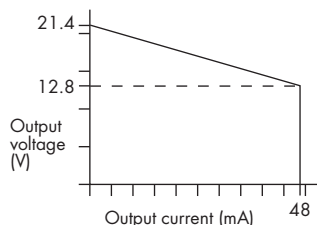

Hazardous-area output

Minimum output voltage: 12.8V at 48mA
Maximum output voltage: 24V from 180Ω
Current limit: 48mA

Output ripple

< 0.5% of maximum output, peak-to-peak

Control input

Suitable for switch contacts, an open collector transistor or logic drive

0 = input switch closed, transistor on or <1.4V applied across terminals 11 & 12

1 = input switch open, transistor off or >4.5V applied across terminals 11 & 12

Response time

Output within 10% of final value within 100ms

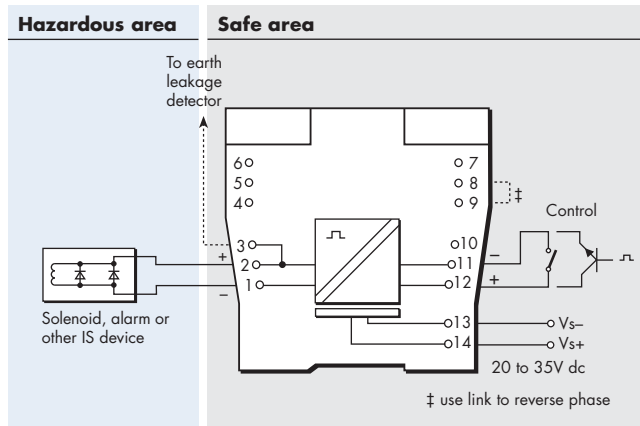

Terminal	Function
1	Output -ve
2	Output +ve
3	To earth leakage detector*
8	Phase reversal link
9	Phase reversal link
11	Control -ve
12	Control +ve
13	Supply -ve
14	Supply +ve

*Signal plug HAZ1-3 is required for access to this function

LED indicators

Green: power indication

Yellow: output status, on when output circuit is active

Maximum current consumption

100mA at 24V dc

Power dissipation within unit

1.3W with typical solenoid valve, output on
1.9W worst case

Safety description

$V_o = 25V$ $I_o = 147mA$ $P_o = 919mW$ $U_m = 253V$ rms or dc

The given data is only intended as a product description and should not be regarded as a legal warranty of properties or guarantee. In the interest of further technical developments, we reserve the right to make design changes.



EUROPE (EMEA)
AMERICAS
ASIA PACIFIC
E-mail: enquiry@mtl-inst.com

Tel: +44 (0)1582 723633
Tel: +1 281 571 8065
Tel: +65 6 487 7887

Fax: +44 (0)1582 422283
Fax: +1 281 571 8069
Fax: +65 6 487 7997

Web site: www.mtl-inst.com

MTL5525 SOLENOID/ ALARM DRIVER

low current, loop-powered, IIC

The MTL5525 enables an on/off device in a hazardous area to be controlled by a switch or voltage change in the safe area. It can drive loads such as solenoids, alarms, LEDs and other low power devices that are certified as intrinsically safe or are classified as non-energy storing simple apparatus. Similar in function to the MTL5521, this module provides lower power output and corresponding reduced safety description.

SPECIFICATION

See also common specification

Number of channels

One

Location of load

Zone 0, IIC, T4-6 hazardous area if suitably certified
Div.1, Group A, hazardous location

Minimum output voltage

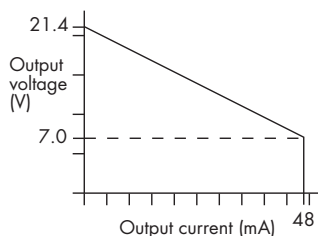

Equivalent output circuit

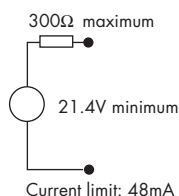

Hazardous-area output

Minimum output voltage: 7V at 48mA
Maximum output voltage: 24V from 300Ω
Current limit: 48mA

Output ripple

< 0.5% of maximum output, peak-to-peak

Response time

Output within 10% of final value within 100ms

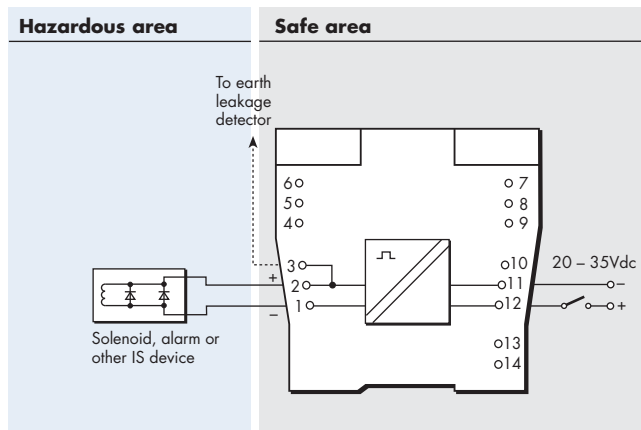

Terminal	Function
1	Output -ve
2	Output +ve
3	To earth leakage detector*
11	Supply -ve
12	Supply +ve

*Signal plug HAZ1-3 is required for access to this function

LED indicators

Yellow: output status, on when output circuit is active

Maximum current consumption

90mA at 24V

Power dissipation within unit

1.4W at 24V

Safety description

$V_o=25V$ $I_o=83.3mA$ $P_o=521mW$ $U_m = 253V$ rms or dc

The given data is only intended as a product description and should not be regarded as a legal warranty of properties or guarantee. In the interest of further technical developments, we reserve the right to make design changes.



EUROPE (EMEA)
AMERICAS
ASIA PACIFIC
E-mail: enquiry@mtl-inst.com

Tel: +44 (0)1582 723633
Tel: +1 281 571 8065
Tel: +65 6 487 7887

Fax: +44 (0)1582 422283
Fax: +1 281 571 8069
Fax: +65 6 487 7997

Web site: www.mtl-inst.com

MTL5526 SWITCH-OPERATED RELAY

two-channel IS-output

The MTL5526 enables two separate IS circuits in a hazardous area to be relay-contact controlled by two on-off switches or logic signals in a safe area. Applications include the calibration of strain-gauge bridges; changing the polarity (and thereby the tone) of an IS sander; the testing of IS fire alarms; and the transfer of safe-area signals into an annunciator with IS input terminals not segregated from each other. The output-relay contacts are certified as non-energy-storing apparatus, and can be connected to any IS circuit without further certification, provided that separate IS circuits are such that they would remain safe if connected together.

SPECIFICATION

See also common specification

Number of channels

Two, fully floating

Location of control circuit

Safe area

Input/output characteristics

Contact/Logic mode

(Inputs suitable for switch contacts, an open-collector transistor or logic drive)

Relay energised if < 450Ω or < 1V applied

Relay de-energised if > 5kΩ or > 2V applied (35V max.)

Loop powered mode

Relay energised if >20V

Relay de-energised if <17V

Power supply failure protection

Relays de-energised if supply fails

Response time

25ms nominal

Contacts (suitable for connection to IS circuits)

1-pole changeover per channel

Contact rating

250V dc, limited to 30V dc for IS applications, 2A (reactive loads must be suppressed)

Contact life expectancy

2 x 10⁷ operations at maximum IS load

Relay drive (see switch setting table)

Switch selection of loop powered or contact/logic control for both channels. Further switch selects "1in2out" mode

LED indicators

Yellow: one provided for each channel, ON when relay is energised

Green: one provided for power indication

Power requirement, V_s

44mA at 24V dc

41mA at 20V dc

60mA at 35V dc

Power dissipation within unit

1.1W maximum at 24V

Safety description (each channel)

Non-energy-storing apparatus: relay contacts may be connected to any IS circuit without further consideration

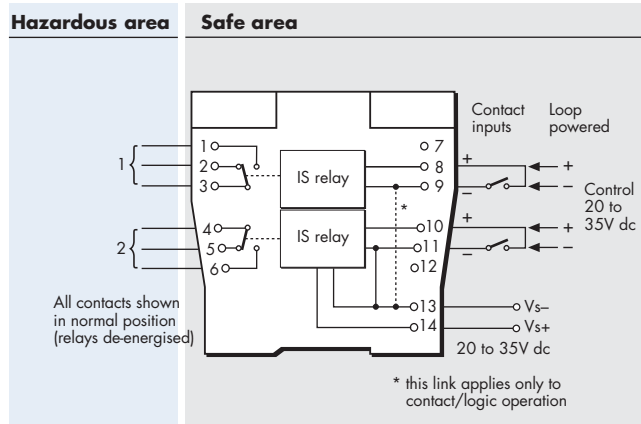

Terminal	Function
1	IS relay output 1 (normally open)
2	IS relay output 1 (normally closed)
3	IS relay output 1 (common)
4	IS relay output 2 (common)
5	IS relay output 2 (normally closed)
6	IS relay output 2 (normally open)
8	Relay 1 control +ve
9	Relay 1 control -ve
10	Relay 2 control +ve
11	Relay 2 control -ve
13	Supply -ve
14	Supply +ve

User switch settings for operating mode

Mode	Function	SW1	SW2	SW3	SW4
Contact/Logic Input	2 ch	Off	On	On	On
	1in2out	On	On	On	On
Loop Powered	2 ch	Off	Off	Off	Off

The given data is only intended as a product description and should not be regarded as a legal warranty of properties or guarantee. In the interest of further technical developments, we reserve the right to make design changes.



EUROPE (EMEA)

AMERICAS

ASIA PACIFIC

E-mail: enquiry@mtl-inst.com

Tel: +44 (0)1582 723633

Tel: +1 281 571 8065

Tel: +65 6 487 7887

Web site: www.mtl-inst.com

Fax: +44 (0)1582 422283

Fax: +1 281 571 8069

Fax: +65 6 487 7997

MTL5541 REPEATER POWER SUPPLY

4/20mA, smart, for 2- or 3-wire transmitters

The MTL5541 provides a fully-floating dc supply for energising a conventional 2- or 3-wire 4/20mA transmitter which is located in a hazardous area, and repeats the current in another floating circuit to drive a safe-area load. For smart 2-wire transmitters, the unit allows bi-directional communications signals superimposed on the 4/20mA signal.

SPECIFICATION

See also common specification

Number of channels

One

Location of transmitter

Zone 0, IIC, T4–6 hazardous area if suitably certified
Div. 1, Group A hazardous location

Safe-area output

Signal range: 4 to 20mA
Under/over-range: 0 to 24mA
Safe-area load resistance: 0 to 360Ω @ 24mA
0 to 450Ω @ 20mA
Safe-area circuit output resistance: > 1MΩ

Safe-area circuit ripple

< 50μA peak-to-peak

Hazardous-area input

Signal range: 0 to 24mA (including over-range)
Transmitter voltage: 16.5V at 20mA

Transfer accuracy at 20°C

Better than 15μA

Temperature drift

< 0.8μA/°C

Response time

Settles to within 10% of final value within 50μs

Communications supported

HART® (terminals 1 & 2 only)

LED indicator

Green: power indication

Maximum current consumption (with 20mA signal)

51mA at 24V

Power dissipation within unit (with 20mA signal)

0.7W at 24V

Safety description

Terminals 2 to 1 and 3:

$V_o=28V$ $I_o=93mA$ $P_o=651mW$ $U_m = 253V$ rms or dc

Terminals 1 to 3:

Simple apparatus ≤1.5V, ≤0.1A and ≤25mW; can be connected without further certification into any IS loop with an open-circuit voltage <28V

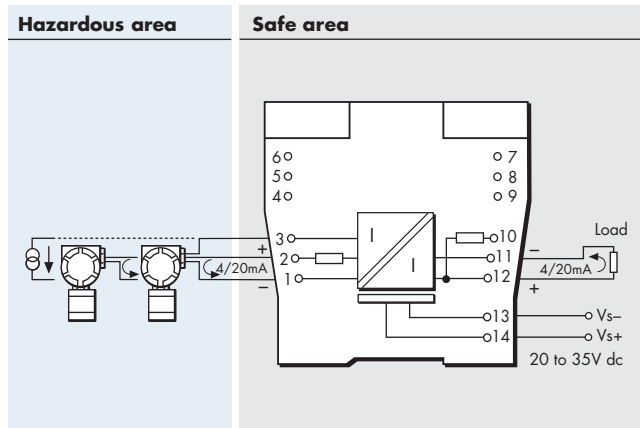

Terminal	Function
1	Current input
2	Transmitter supply +ve
3	Common
10	Output +ve via 220Ω for HART apps.
11	Output -ve
12	Output +ve
13	Supply -ve
14	Supply +ve

The given data is only intended as a product description and should not be regarded as a legal warranty of properties or guarantee. In the interest of further technical developments, we reserve the right to make design changes.



EUROPE (EMEA)
AMERICAS
ASIA PACIFIC
E-mail: enquiry@mtl-inst.com

Tel: +44 (0)1582 723633
Tel: +1 281 571 8065
Tel: +65 6 487 7887

Fax: +44 (0)1582 422283
Fax: +1 281 571 8069
Fax: +65 6 487 7997

Web site: www.mtl-inst.com

MTL5541A/5541AS

CURRENT REPEATER

4/20mA passive input for HART® transmitters

The MTL5541A provides an input for separately powered 4/20mA transmitters and also allows bi-directional transmission of HART communication signals superimposed on the 4/20mA loop current, so that the transmitter can be interrogated either from the operator station or by a hand-held communicator (HHC). Alternatively, the MTL5541AS acts as a current sink for a safe-area connection rather than driving a current into the load.

SPECIFICATION

See also common specification

Number of channels

One

Location of transmitter

Zone 0, IIC, T4-6 hazardous area if suitably certified
Div.1, Group A, hazardous location

Hazardous area input

Signal range: 4 to 20mA
Under/over-range: 1.0 to 21.5mA

Input impedance for HART signals

at terminals 1, 2: > 230Ω

Maximum input volt drop

at terminals 1, 2: < 6.6V
i.e. a transmitter load of 330Ω at 20mA

Safe-area output

Signal range: 4 to 20mA
Under/over-range: 1.0 to 21.5mA

Safe-area load resistance (MTL5541A)

Conventional transmitters: 0 to 360Ω
Smart transmitters: 250Ω ±10%

Safe-area load (MTL5541AS)

Current sink: 600Ω max.
Maximum voltage source: 24V DC
Safe-area circuit output resistance: > 1MΩ

Safe-area circuit ripple

< 50μA peak-to-peak up to 80kHz

Communications supported

HART

Transfer accuracy at 20°C

Better than 20μA

Temperature drift

< 1μA/°C

Response time

Settles within 200μA of final value after 20ms

LED indicator

Green: power indication

Power requirement (with 20mA signal)

45mA at 24V
50mA at 20V
35mA at 35V

Power dissipation within unit (with 20mA signal)

0.9W at 24V
0.9W at 35V

Safety description

Terminals 1 to 2:

8.6V (diode). This voltage must be considered when calculating the load capacitance.

Non-energy-storing apparatus ≤1.5V, ≤0.1A and ≤25mW; can be connected without further certification into any IS loop with an open-circuit voltage <28V

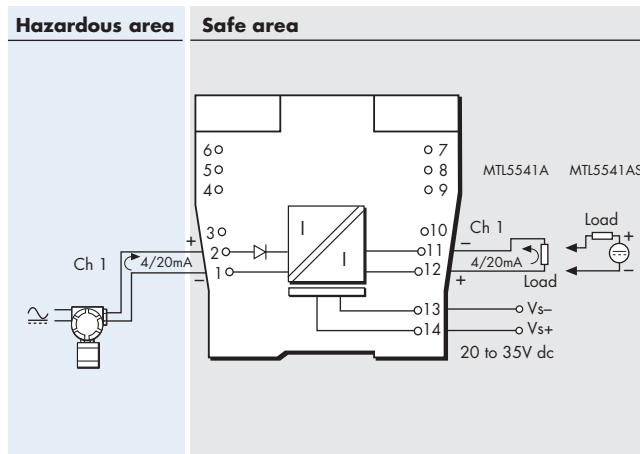

Terminal	Function
1	Input -ve
2	Input +ve
11	Output -ve (+ve current sink)
12	Output +ve (-ve current sink)
13	Supply -ve
14	Supply +ve

The given data is only intended as a product description and should not be regarded as a legal warranty of properties or guarantee. In the interest of further technical developments, we reserve the right to make design changes.



EUROPE (EMEA)
AMERICAS
ASIA PACIFIC
E-mail: enquiry@mtl-inst.com

Tel: +44 (0)1582 723633
Tel: +1 281 571 8065
Tel: +65 6 487 7887

Fax: +44 (0)1582 422283
Fax: +1 281 571 8069
Fax: +65 6 487 7997

Web site: www.mtl-inst.com

MTL5544 REPEATER POWER SUPPLY

two channel, 4/20mA, smart,
for 2- or 3- wire transmitters

The MTL5544 provides fully-floating dc supplies for energising two conventional 2-wire or 3-wire 4/20mA or 'smart' transmitters located in a hazardous area, and repeats the current in other circuits to drive two safe-area loads. For smart transmitters, the unit allows bi-directional transmission of digital communication signals superimposed on the 4/20mA signal so that the transmitter can be interrogated either from the operator station or by a hand-held communicator.

SPECIFICATION

See also common specification

Number of channels

Two

Location of transmitter

Zone 0, IIC, T4–6 hazardous area if suitably certified
Div. 1, Group A hazardous location

Safe-area output

Signal range: 4 to 20mA
Under/over-range: 0 to 24mA
Safe-area load resistance: 0 to 360Ω @ 24mA
0 to 450Ω @ 20mA
Safe-area circuit output resistance: > 1MΩ

Safe-area circuit ripple

< 50μA peak-to-peak

Hazardous-area input

Signal range: 0 to 24mA (including over-range)
Transmitter voltage: 16.5V at 20mA

Transfer accuracy at 20°C

Better than 15μA

Temperature drift

< 0.8μA/°C

Response time

Settles to within 10% of final value within 50μs

Communications supported

HART® (terminals 1 & 2 and 4 & 5 only)

LED indicator

Green: power indication

Maximum current consumption (with 20mA signals)

96mA at 24V dc

Power dissipation within unit (with 20mA signals)

1.4W at 24V dc

Safety description (each channel)

Terminals 2 to 1 and 3, and 5 to 4 and 6:

$V_o=28V$ $I_o=93mA$ $P_o=651mW$ $U_m=253V$ rms or dc

Terminals 1 to 3 and 4 to 6:

Simple apparatus $\leq 1.5V$, $\leq 0.1A$ and $\leq 25mW$; can be connected without further certification into any IS loop with an open-circuit voltage <28V

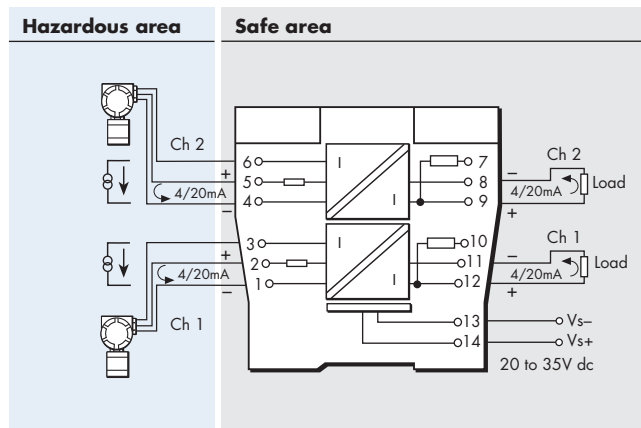

Terminal	Function
1	Ch1 current input
2	Ch1 transmitter supply +ve
3	Ch1 common
4	Ch2 current input
5	Ch2 transmitter supply +ve
6	Ch2 common
7	Ch2 output +ve via 220Ω for HART apps.
8	Ch2 output -ve
9	Ch2 output +ve
10	Ch1 output +ve via 220Ω for HART apps.
11	Ch1 output -ve
12	Ch1 output +ve
13	Supply -ve
14	Supply +ve

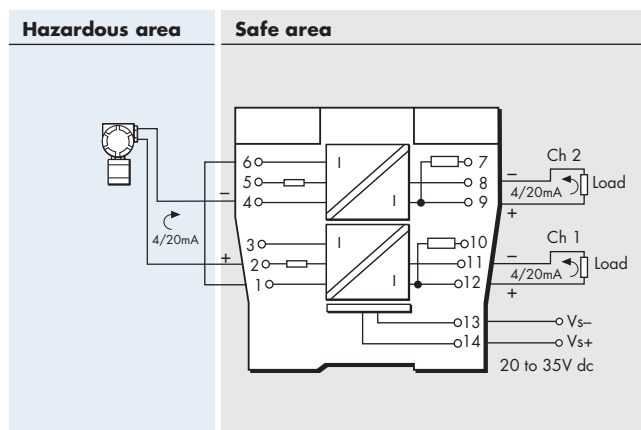

The MTL5544 can also be used to drive two safe-area loads from a single 2-wire transmitter (i.e. 1 in, 2 out) by interconnecting the input channels as shown in the diagram here.

Note: In this mode the HART data is transferred via channel 1 output only.

The given data is only intended as a product description and should not be regarded as a legal warranty of properties or guarantee. In the interest of further technical developments, we reserve the right to make design changes.



EUROPE (EMEA)
AMERICAS
ASIA PACIFIC
E-mail: enquiry@mtl-inst.com

Tel: +44 (0)1582 723633
Tel: +1 281 571 8065
Tel: +65 6 487 7887

Fax: +44 (0)1582 422283
Fax: +1 281 571 8069
Fax: +65 6 487 7997

Web site: www.mtl-inst.com

MTL5544A/5544AS

CURRENT REPEATER

4/20mA passive input for HART® transmitters

The MTL5544A provides an input for separately powered 4/20mA transmitters and also allows bi-directional transmission of HART communication signals superimposed on the 4/20mA loop current, so that the transmitter can be interrogated either from the operator station or by a hand-held communicator (HHC). Alternatively, the MTL5544AS acts as a current sink for a safe-area connection rather than driving a current into the load.

SPECIFICATION

See also common specification

Number of channels

Two

Location of transmitter

Zone 0, IIC, T4-6 hazardous area if suitably certified
Div.1, Group A, hazardous location

Hazardous area input

Signal range: 4 to 20mA
Under/over-range: 1.0 to 21.5mA

Input impedance for HART signals

at terminals 1, 2 and 4, 5: > 230Ω

Maximum input volt drop

at terminals 1, 2 and 4, 5: < 6.6V
i.e. a transmitter load of 330Ω at 20mA

Safe-area output

Signal range: 4 to 20mA
Under/over-range: 1.0 to 21.5mA
Safe-area load resistance (MTL5544A)
Conventional transmitters: 0 to 360Ω
Smart transmitters: 250Ω ±10%
Safe-area load (MTL5544AS)
Current sink: 600Ω max.
Maximum voltage source: 24V DC
Safe-area circuit output resistance: > 1MΩ

Safe-area circuit ripple

< 50μA peak-to-peak up to 80kHz

Communications supported

HART

Transfer accuracy at 20°C

Better than 20μA

Temperature drift

< 1μA/°C

Response time

Settles within 200μA of final value after 20ms

LED indicator

Green: power indication

Power requirement (with 20mA signal)

70mA at 24V

85mA at 20V

50mA at 35V

Power dissipation within unit (with 20mA signal)

1.6W at 24V

1.7W at 35V

Safety description

Terminals 1 to 2 and 4 to 5:

8.6V (diode). This voltage must be considered when calculating the load capacitance.

Non-energy-storing apparatus ≤1.5V, ≤0.1A and ≤25mW; can be connected without further certification into any IS loop with an open-circuit voltage < 28V

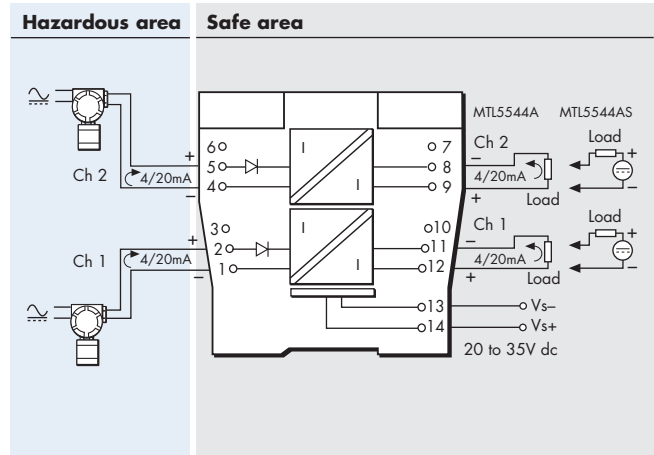

Terminal	Function
1	Ch1 input -ve
2	Ch1 input +ve
4	Ch2 input -ve
5	Ch2 input +ve
8	Ch2 output -ve (+ve current sink)
9	Ch2 output +ve (-ve current sink)
11	Ch1 output -ve (+ve current sink)
12	Ch1 output +ve (-ve current sink)
13	Supply -ve
14	Supply +ve

The given data is only intended as a product description and should not be regarded as a legal warranty of properties or guarantee. In the interest of further technical developments, we reserve the right to make design changes.



EUROPE (EMEA)

AMERICAS

ASIA PACIFIC

E-mail: enquiry@mtl-inst.com

Tel: +44 (0)1582 723633

Tel: +1 281 571 8065

Tel: +65 6 487 7887

Web site: www.mtl-inst.com

Fax: +44 (0)1582 422283

Fax: +1 281 571 8069

Fax: +65 6 487 7997

MTL5546/5546Y ISOLATING DRIVER

for 4–20mA smart valve positioners
with line fault detection

The MTL5546 accepts a 4/20mA floating signal from a safe-area controller to drive a current/pressure converter (or any other load up to 800Ω) in a hazardous area. For smart valve positioners, the module also permits bi-directional transmission of digital communication signals so that the device can be interrogated either from the operator station or by a hand-held communicator. Process controllers with a readback facility can detect open or short circuits in the field wiring: if these occur, the current taken into the terminals drops to a preset level. The MTL5546Y is very similar to the MTL5546 except that it provides open circuit detection *only* (i.e. no short-circuit detection).

SPECIFICATION

See also common specification

Number of channels

One

Location of I/P converter

Zone 0, IIC, T4–6 hazardous area if suitably certified
Div. 1, Group A, hazardous location

Working range

4 to 20mA

Digital signal bandwidth

500Hz to 10kHz

Maximum load resistance

800Ω (16V at 20mA)

Minimum load resistance

90Ω (short-circuit detection at < 50Ω)

Output resistance

> 1MΩ

Under/over range capability

Under range = 1mA

Over range = 24mA (load ≤ 520Ω)

Input and output circuit ripple

< 40μA peak-to-peak

Transfer accuracy at 20°C

Better than 20μA

Temperature drift

< 1.0μA/°C

Input characteristics

Field wiring state	MTL5546	MTL5546Y
Normal	< 6.0V	< 6.0V
Open-circuit	< 0.9mA	< 0.5mA
Short-circuit	< 0.9mA	N.A.

Response time

Settles within 200μA of final value within 100ms

Communications supported

HART®

LED indicator

Green: power indication

Maximum current consumption (with 20mA signals into 250Ω load)

35mA at 24V dc

Power dissipation within unit (with 20mA signals into 250Ω load)

0.8W at 24V

Safety description

$V_o=28V$ $I_o=93mA$ $P_o=651mW$ $U_m = 253V$ rms or dc

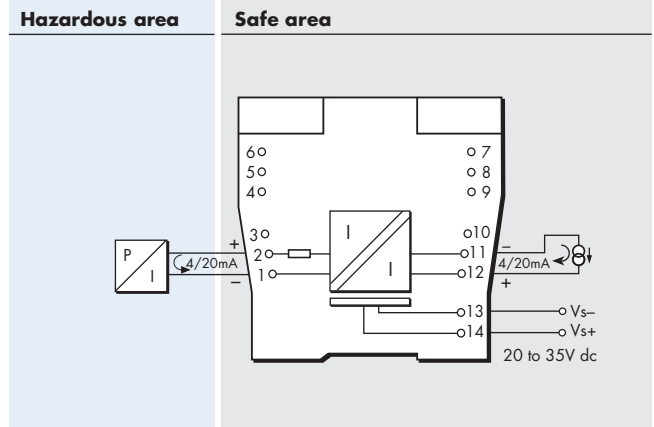

Terminal	Function
1	Output -ve
2	Output +ve
11	Input -ve
12	Input +ve
13	Supply -ve
14	Supply +ve

The given data is only intended as a product description and should not be regarded as a legal warranty of properties or guarantee. In the interest of further technical developments, we reserve the right to make design changes.



EUROPE (EMEA)

AMERICAS

ASIA PACIFIC

E-mail: enquiry@mtl-inst.com

Tel: +44 (0)1582 723633

Tel: +1 281 571 8065

Tel: +65 6 487 7887

Web site: www.mtl-inst.com

Fax: +44 (0)1582 422283

Fax: +1 281 571 8069

Fax: +65 6 487 7997