



General-Purpose AC Servo

# **MELSERVO-J2-Super Series**

General-Purpose Interface

**MODEL**

## **MR-J2S-□A**

SERVO AMPLIFIER

INSTRUCTION MANUAL

# 11. OUTLINE DIMENSION DRAWINGS

## 11. OUTLINE DIMENSION DRAWINGS

### 11.1 Servo amplifiers

- (1) MR-J2S-10A to MR-J2S-60A  
MR-J2S-10A1 to MR-J2S-40A1

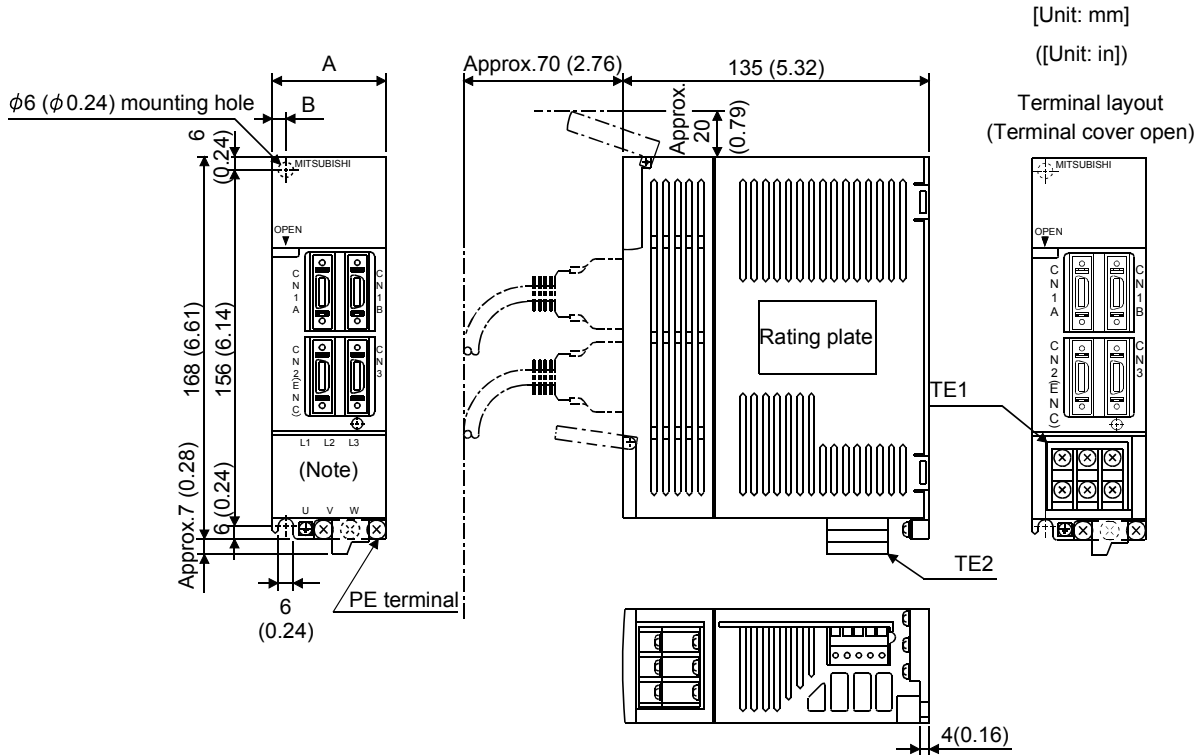

Servo amplifier	Variable dimensions		Mass [kg]([lb])
	A	B	
MR-J2S-10A(1)	50 (1.97)	6 (0.24)	0.7 (1.54)
MR-J2S-20A(1)			
MR-J2S-40A(1)	70 (2.76)	22 (0.87)	1.1 (2.43)
MR-J2S-60A			

Note. This data applies to the 3-phase 200 to 230VAC and 1-phase 230VAC power supply models.

