



General-Purpose AC Servo

MELSERVO-J2-Super Series

SSCNET Compatible

MODEL

MR-J2S-□B

SERVO AMPLIFIER

INSTRUCTION MANUAL

10. OUTLINE DIMENSION DRAWINGS

(3) MR-J2S-200B • MR-J2S-350B

[Unit: mm]
 ([Unit: in])

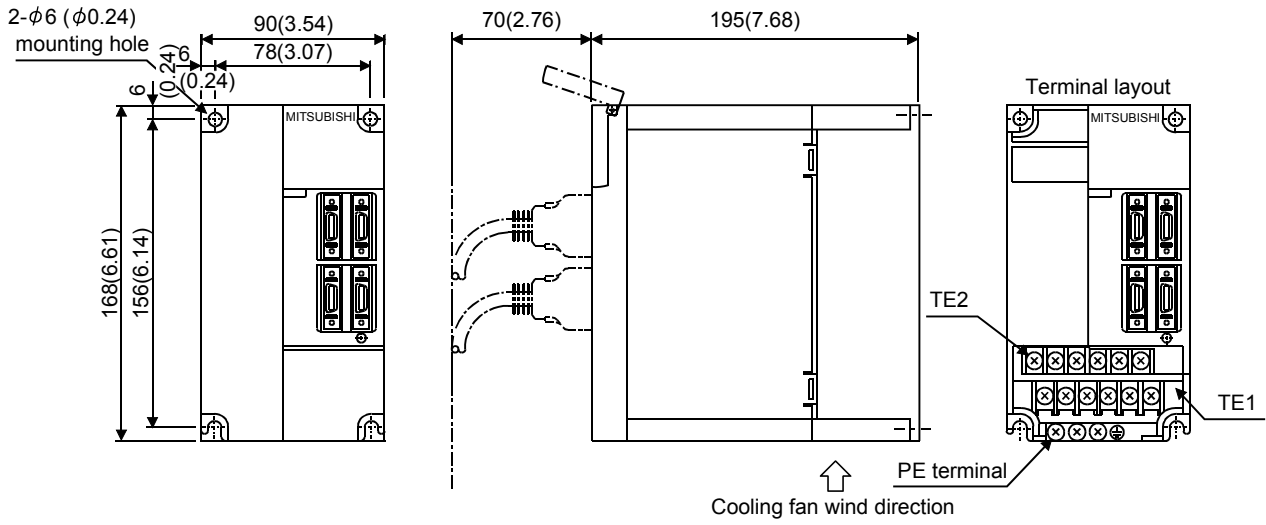

Servo amplifier	Mass [kg](lb)
MR-J2S-200B	2.0
MR-J2S-350B	(4.41)

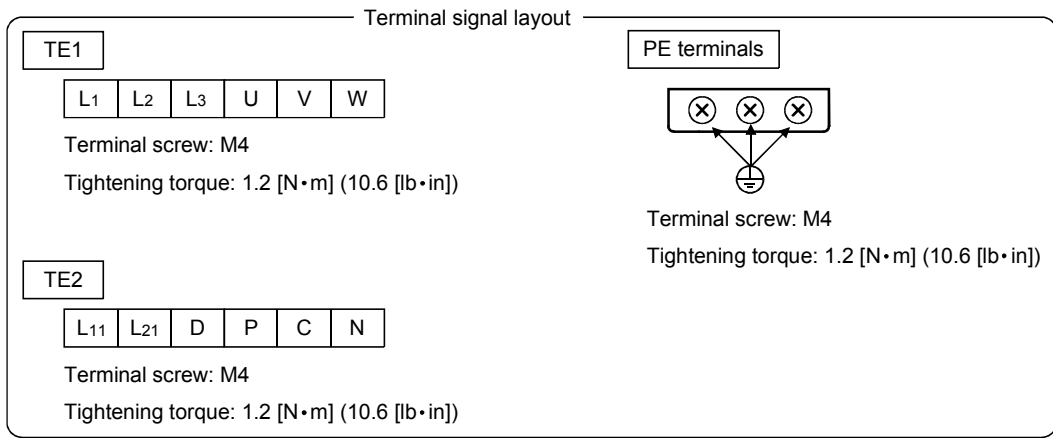

Mounting Screw
 Screw Size: M5
 Tightening torque:
 3.24 [N·m]
 (28.676 [lb·in])