

# 180° Angular Style Air Gripper

## Series *MHY2/MHW2*

Cam Style / Rack & Pinion Style

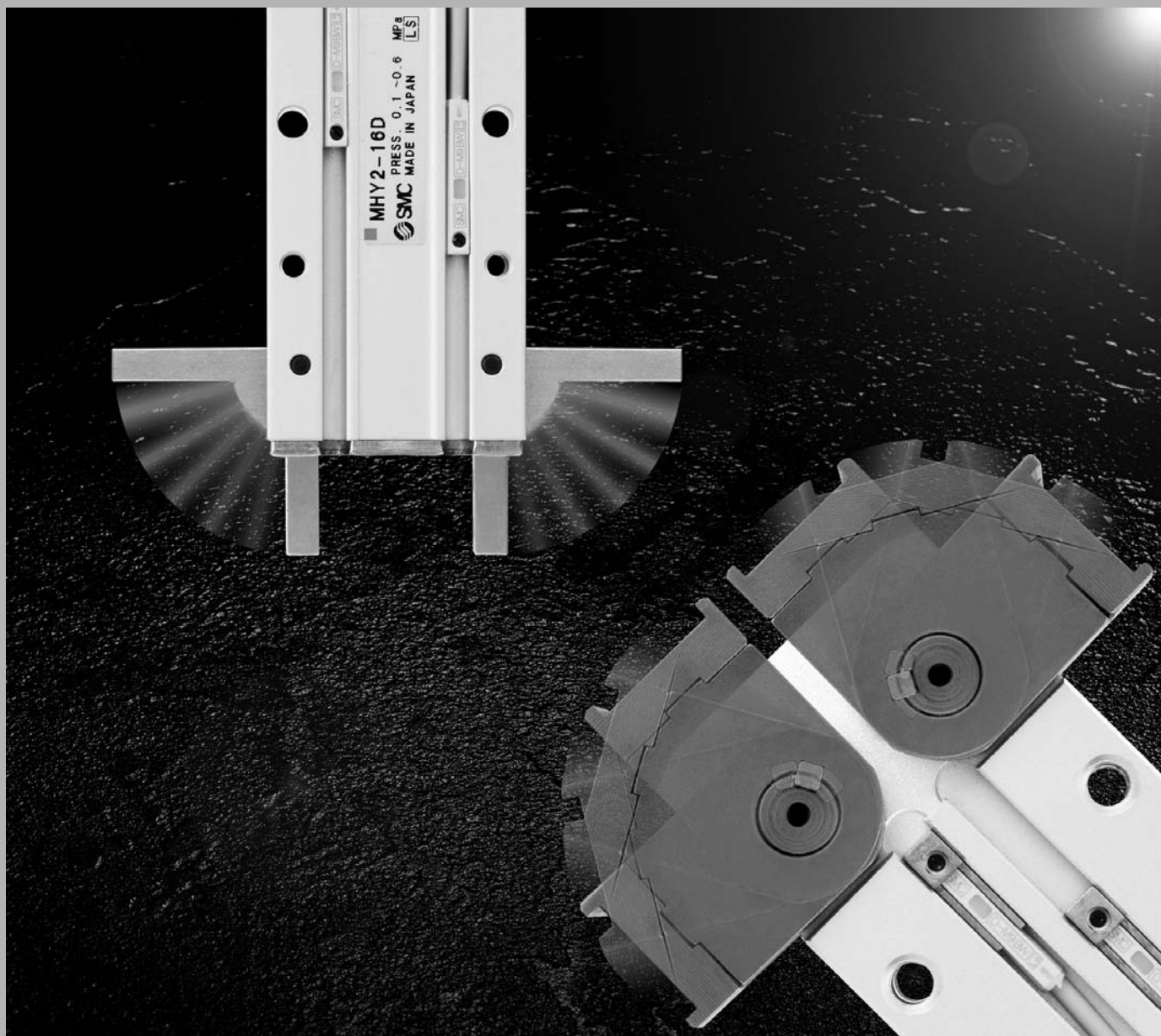

MHZ

MHF

MHL

MHR

MHK

MHS

MHC

MHT

**MHY**

**MHW**

-X□

MRHQ

MA

D-□

# 180° Angular Style Air Gripper

Cam Style

Rack & Pinion Style

# Series *MHY2/MHW2*

## Series *MHY2/Cam Style*

Light and compact size in small bore sizes

Model	Bore size (mm)	Gripping moment* (N·m)	Over length L (mm)	Mass (g)
MHY2-10D	10	0.16	71	70
MHY2-16D	16	0.54	84	150
MHY2-20D	20	1.10	106	320
MHY2-25D	25	2.28	131	560

\* At the pressure of 0.5 MPa

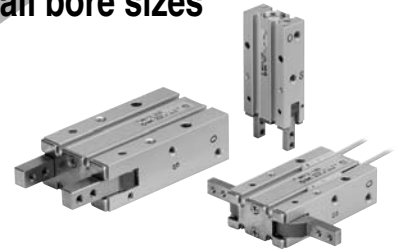

**Improved mounting repeatability**

**Auto switch mounting at 4 locations**

**Resistance to dusty environments**

Reduced opening sizes helps prevent foreign objects from entering.

**Stainless steel fingers are standard.**

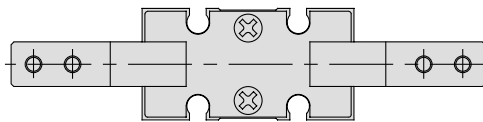
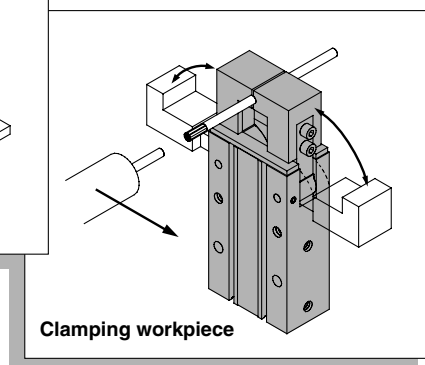
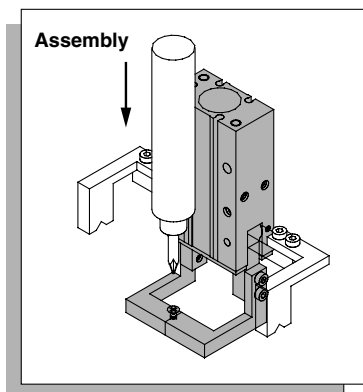
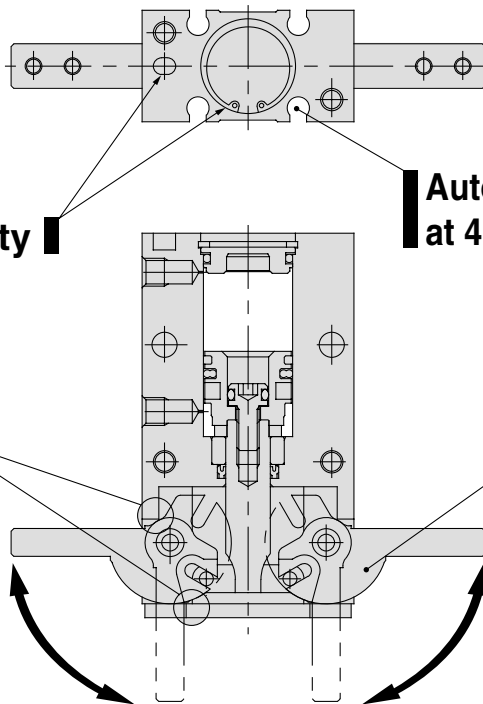

### Series Variations

	Bore size (mm)						
	10	16	20	25	32	40	50
Cam style Series <i>MHY2</i>	●	●	●	●			
Rack & Pinion style Series <i>MHW2</i>			●	●	●	●	●

## MHY2-20D

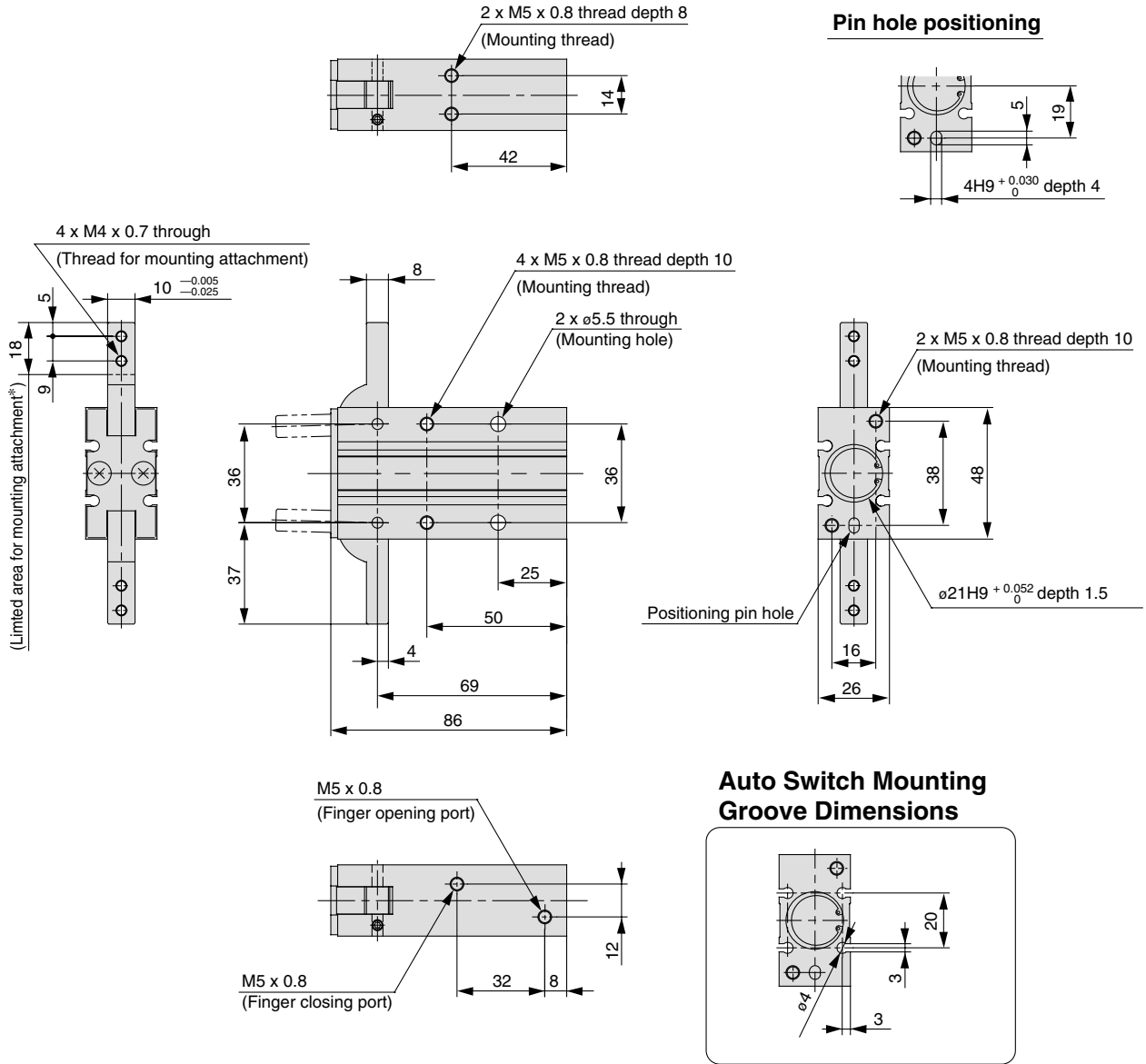

## MHY2-20D2

Opening/Closing direction through-hole type

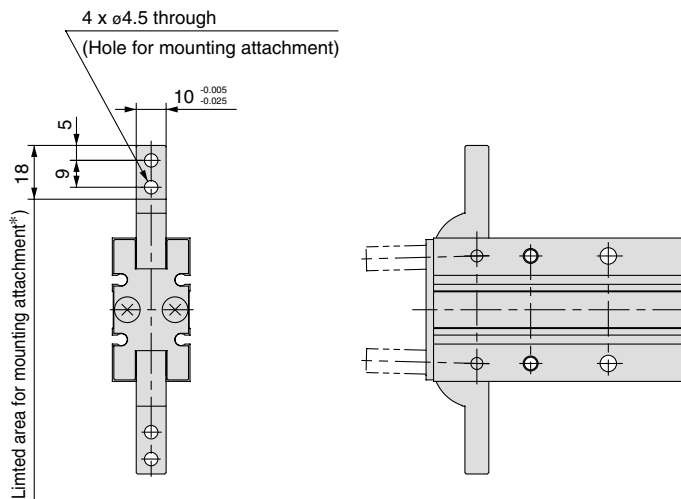

\* Do not extend the attachment from limited area for mounting to avoid interference with the attachment or main body.

- MHZ
- MHF
- MHL
- MHR
- MHK
- MHS
- MHC
- MHT
- MHY**
- MHW
- X□
- MRHQ
- MA
- D-□