

FAST 50

- SOFT START & STOP
 - Rilevamento ostacoli | *Obstacle detection*
 - Fine corsa | *Stroke limit*
 - Velocità | *Speed* 23 mm/sec
 - Forza di spinta | *Thrust force* 500 N
 - Servizio | *Type of service* S2 - 4 min
 - Temp min-max -5°C / +50°C
- IP55

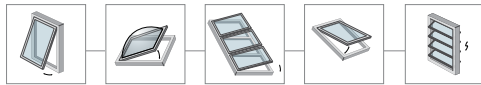

FAST

Article	Product code	Colour	Strokes	Lenght L	Push pull	Power	Motor voltage	Weight	Pieces
50/160 230V basic	MFAST 160 H 0B 00	■ Grey RAL 7035	160 mm	299,5	500 N	170W	0,7A	1,9 Kg	1
50/200 230V basic	MFAST 200 H 0B 00	■ Grey RAL 7035	200 mm	299,5	500 N	170W	0,7A	2,0 Kg	1
50/300 230V basic	MFAST 300 H 0B 00	■ Grey RAL 7035	300 mm	299,5	500 N	170W	0,7A	2,2 Kg	1
50/400 230V basic	MFAST 400 H 0B 00	■ Grey RAL 7035	400 mm	299,5	500 N	170W	0,7A	2,4 Kg	1

Comando a parete
Push-button



L < 125 cm
Base / Length

Fino a **30** finestre
Up to **30** windows

Pale frangisole

Solar shading

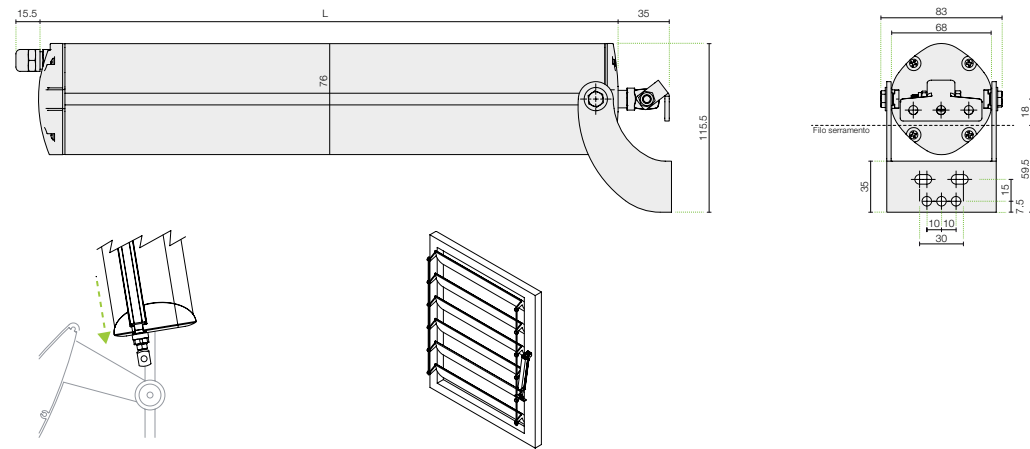

Apertura a sporgere

Top hung outward opening window

