

Series 90 Modutrol IV™ Motors

PRODUCT DATA



APPLICATION

The Series 90 Modutrol IV™ Motors are spring return and non-spring return modulating proportional control motors. Use these motors with controllers that provide a Series 90 output to operate dampers or valves.

FEATURES

- Replaces M934A,D, M941, M944A,C,D, M945A,D,F, M954, M965, and M975 motors.
- Integral junction box provides NEMA 3 weather protection.
- Integral spring return returns motor to normal position when power is interrupted.
- Motor and circuitry operate from 24 Vac. Models available with factory installed transformer, or a field added internal transformer.
- Quick-connect terminals are standard—screw terminal adapter is available.
- Adapter bracket for matching shaft height of older motors is available.
- Motors have field adjustable stroke (90° to 160°).
- Die-cast aluminum housing.
- Integral auxiliary switches are available factory mounted, or can be field added.
- Nominal timing standard of 30 seconds (90° stroke), and 60 seconds (160° stroke). Other timings available.
- Spring return motors can operate valve linkages from power end or auxiliary end shafts for normally closed or normally open valve applications.
- All models have dual shafts (slotted and tapped on both ends).
- All models have auxiliary switch cams.
- Fixed torque throughout the entire voltage range.
- Motors are designed for either normally open or normally closed valves and dampers.
- Field addable interface modules can be mounted in the junction box to upgrade the motor to Series 70 (electronic) control.

Contents

Application	1
Features	1
Specifications	2
Ordering Information	2
Wiring	7
Settings and Adjustments	10
Operation	11
Checkout	13
Replacement	13

SPECIFICATIONS

TRADELIN Models: Selected and packaged to provide ease of stocking, ease of handling and maximum replacement value. Specifications are the same as those of standard models unless specified otherwise.

NOTE: Auxiliary switches can only be added to motors that include auxiliary switch cams. (These cams cannot be field-added.)

Modutrol IV Order Number Guide: See Table 1.

Table 1. Modutrol IV Series 2 and 3 Model Number Guide.

M	Motor				
	91	Proportioning Series 90 Control			
	94	Flame Safeguard Firing Rate Motor			
	7	60 lb-in. Spring Return	75 lb-in. Non-Spring Return		
	8		150 lb-in. Non-Spring Return		
	9		300 lb-in. Non-Spring Return		
	4	Dual-ended shaft	Non-Spring Return		
	5		Normally Closed (NC) Spring Return		
		F	2 Auxiliary Switches	Adjustable Stroke	Normally Closed
M	91	8	4	F	XXXX See HIC Catalog for Complete O.S. Number

NOTE: Torque designation corresponds to torque rating at standard timing (nominally 60 sec for 160° and 30 sec for 90° except for 300 lb-in. motors which have timings of 2 or 4 min).

Dimensions: Refer to Fig. 2. **Electrical**

Minimum: -40° F (-40° C).

Ratings: Refer to Table 2. **Control**

NOTE: 25% duty cycle indicates that the motor operates for 6 out of every 24 hours.

Inputs: Proportional, Series 90.

NOTE: Motor Series 90 control can be either Electronic, or Mechanical (135 ohm).

Dead Weight Load On Shaft:

Power or Auxiliary End: 200 lb (90.8 kg) maximum.
Maximum Combined Load: 300 lb (136 kg). (Dual shaft motors only.)

Auxiliary Switch Ratings: Refer to Table 3.

Crankshaft: 3/8 in. (9.5 mm) square. (All models built after 2006 have dual end shaft.)

Ambient Temperature Ratings:

Maximum: 150° F (66° C) at 25% duty cycle.

ORDERING INFORMATION

When purchasing replacement and modernization products from your TRADELINE® wholesaler or distributor, refer to the TRADELINE® Catalog or price sheets for complete ordering number. If you have additional questions, need further information, or would like to comment on our products or services, please write or phone:

1. Your local Honeywell Environmental and Combustion Controls Sales Office (check white pages of your phone directory).
2. Honeywell Customer Care
1985 Douglas Drive North
Minneapolis, Minnesota 55422-4386
3. Honeywell Industrial Combustion
Luchthavenlaan 16
1800 Vilvoorde
Belgium

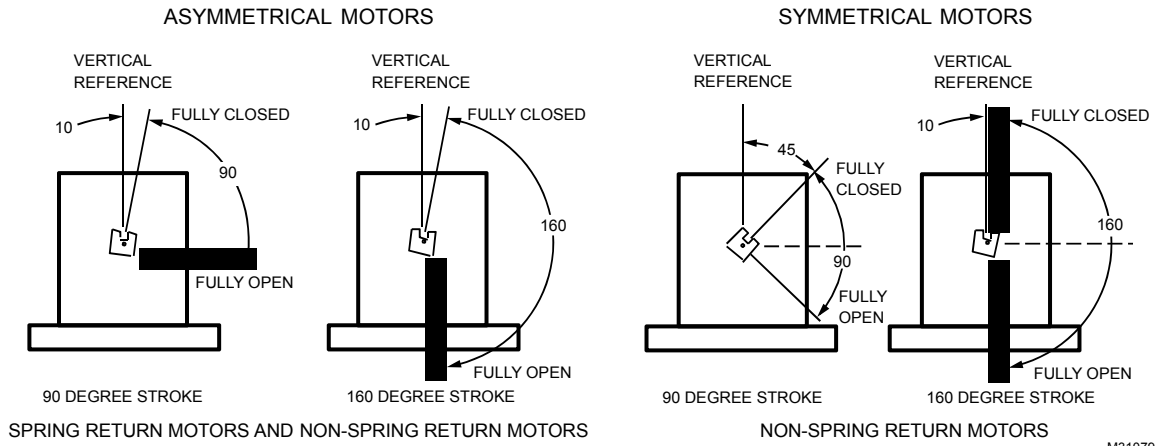

M31079

Fig. 1. Stroke.

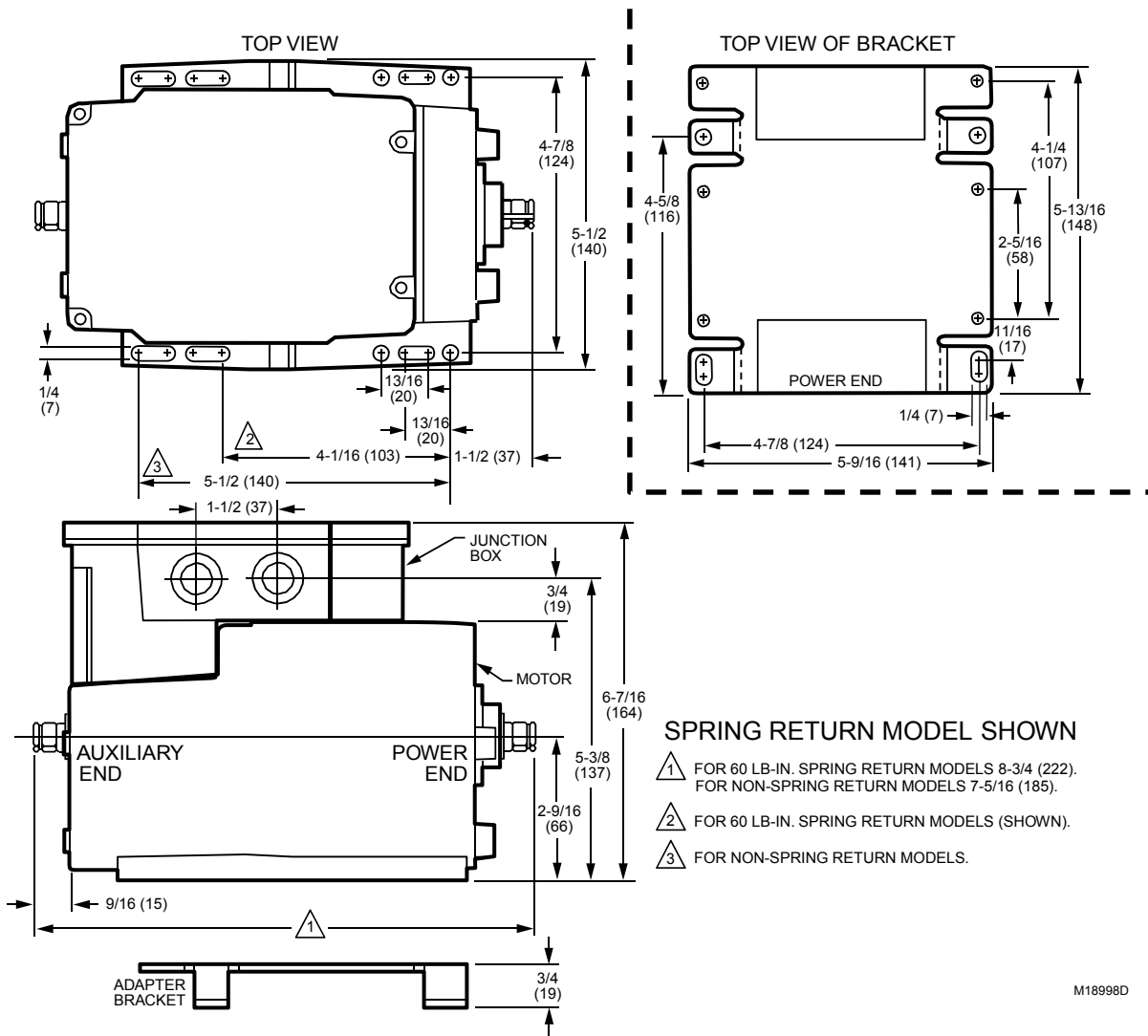

M18998D

Fig. 2. Modutrol IV Motor mounting dimensions in inches (mm).

Stroke: Models available with field adjustable stroke from 90° to 160° (See Settings and Adjustments figure 11).

Table 2. Power Consumption Ratings.

Power Consumption	
Family	VA Rating
M9174F	12
M9184F	15
M9185F	20
M9484F	15
M9494F	20

Table 3. Auxiliary Switch Ratings (in Amps).

Single Contact Rating ^a	120 V	240 V
Full Load	7.2	3.6
Locked Rotor	43.2	21.6

^a 40 VA pilot duty, 120/240 Vac on opposite contact.

Timing And Torque: Refer to Table 5.

Approvals:

Underwriters Laboratories Inc. Listed: File No. E4436, Guide No. XAPX to US and Canadian standards.
U.S. Patents: pending

Table 4. Primary 50017460-001 Color Code

Lead Color	Primary Voltage
Brown	24 VAC
White	120 VAC
Blue	230 VAC
Black	Common

All Transformers have brown secondary (24 VAC) wires.

Table 5. Series 90 Modutrol Motor Timing and Torque Ratings.

Nominal Timing ^a in sec		Rated Torque in lb-in. (N•m) ^b			
		Normal Running Torque		Breakaway Torque ^c	
90°	160°	Spring Return	Non-Spring Return	Spring Return	Non-Spring Return
30	60	—	35 (4)	—	70 (8)
15 ^d /30	30 ^d /60	60 (6.8)	75 (8.5)	120 (13.6)	150 (17)
30	60	—	150 (17)	—	300 (34)
60	120	—	300 (34)	—	600 (68)

^a Timings apply to all TRADELINE models. Some OEM models are available with non-standard timing/torque.

^b The torque rating for dual-ended shaft motors is the sum of the shaft torques (power-end torque plus auxiliary-end torque).

^c Breakaway torque is maximum torque available to overcome occasional large loads such as a seized damper or valve.

^d Low timing is for M9184D1005 only.

NOTE: Some 150 lb-in. and 300 lb-in. torque adjustable stroke motors have timings that are twice that of the nominal timing.

IMPORTANT

Never use a Modutrol Motor continuously at the Breakaway Torque rating.

Accessories:

- 220736B Internal dual Auxiliary Switch Kit can be field-installed.
- 220738A Adapter Bracket raises motor shaft height by 19 mm to match that of previous Modutrol Motor models.
- 220741A Screw Terminal Adapter converts the standard quick-connect terminals to screw terminals.
- 221455A Infinitely Adjustable Crank Arm approximately 0.75 inch shorter than the 4074ELY Crank Arm, can rotate through downward position and clear base of motor without requiring use of adapter bracket.
- 221508A Resistor Board plugs onto Series 90 Motor quick-connect wire terminals. Provides same functionality as 4074BYK, 4074EAU, 4074EDC, or 4074EED Resistor Kits.
- 4074BYK Series 90 Resistor Kit provides for unison control of up to six Series 90 Motors.

- 4074EAU W973 Resister Kit provides for control of two or three Series 90 Motors from a W973 Single-zone Logic Panel or W7100 Discharge Air Controller.
- 4074EDC 4-20 mA Resistor Kit drives one Series 90 Motor from a 4-20 mA controller.
- 4074EED Unison Control 4-20 mA Resistor Kit provides for control of up to four Series 90 Motors from one 4-20 mA controller.
- 4074ERU Weatherproofing Kit provides NEMA 3 rating for Modutrol IV Motors mounted in position other than upright.
- 50017460-001 Internal Transformer; 24/120/230 Vac 50/60 Hz primary, 24 Vac secondary, quick connect terminals.
- 50017460-003 Internal Transformer; 120 Vac 50/60 Hz primary, 24 Vac secondary, quick connect terminals.
- 7617ADW Crank Arm approximately 0.75 inch shorter than 7616BR Crank Arm. Can rotate through downward position and clear base of motor without requiring use of adapter bracket.
- Q100 Linkage connects Modutrol Motor to V51 Butterfly Valve. Requires the 220738A adapter bracket (packed with TRADELINE Modutrol IV Motors).

- Q181 Auxiliary Potentiometer for sequence or unison control of 1 to 4 additional modulating (Series 90) motors.
- Q209E,F Potentiometer limits motor minimum position.
- Q5001 Bracket and Linkage Assembly connects Modutrol Motor to a water or steam globe valve.
- Q605 Damper Linkage connects motor to damper. Includes motor crank arm.
- Q607 External Auxiliary Switch controls auxiliary equipment as a function of motor position.
- Q7130A Interface Module with selectable voltage ranges (4-7 Vdc, 6-9 Vdc, and 10.5-13.5 Vdc) adapts motor to M71XX function.
- Q7230A Interface Module with selectable control (2-10 Vdc or 4-20 mA) and adjustable zero and span adapts motor to M72XX function.
- Q7330A Interface Module for W936 Economizer applications adapts motor to M73XX function.

Table 6. Modutrol Motor Cross-Reference.

Original Motor	Replacements
M941, M944A,C,D, M954	M9184F, M9194F, M9484F, M9494F
M934D	M9174F
M945A,D,F, M955	M9185F

INSTALLATION

When Installing this Product...

1. Read these instructions carefully. Failure to follow them could damage the product or cause a hazardous condition.
2. Check the ratings given in the instructions and on the product to make sure the product is suitable for your application.
3. Installer must be a trained, experienced service technician.
4. After installation is complete, check out product operation as provided in these instructions.



CAUTION

Electrical Shock or Equipment Damage Hazard.
Can shock individuals or short equipment circuitry.
 Disconnect all power supplies before installation.
 Motors with auxiliary switches can have more than one disconnect.



CAUTION

Equipment Damage Hazard.
Can damage the motor beyond repair.
 Never turn the motor shaft by hand or with a wrench.
 Forcibly turning the motor shaft damages the gear train and stroke limit contacts.

IMPORTANT

Always conduct a thorough checkout when installation is complete.

Location

Allow enough clearance for installing accessories and motor servicing when selecting a location (See Fig. 2). If located outdoors, use liquid-tight conduit connectors with the junction box to provide NEMA 3 weather protection. If mounted outdoors in a position other than upright, install a 4074ERU Weatherproofing Kit and liquid-tight connectors to provide NEMA 3 protection.



CAUTION

Motor Damage Hazard.
Deteriorating vapors and acid fumes can damage metal parts.
 Install motor in areas free of acid fumes and other deteriorating vapors.

In excessive salt environments, mounting base and screws should be zinc or cadmium plated, not stainless steel or brass. Use the 220738A Adapter Bracket for mounting on these surfaces.

Mounting



CAUTION

Equipment Damage Hazard.

Can damage the motor beyond repair.

Always install motors with the crankshaft horizontal. Improper motor mounting can result in inadequate motor gear train lubrication.

Use the following guidelines for proper motor mounting:

- Always install motors with the crankshaft horizontal.
- Mounting flanges extending from motor housing base are drilled for 1/4 inch (6.4 mm) machine screws or bolts.
- Non-Spring Return Motors are shipped from the factory in the closed position (at the limit of counterclockwise rotation, as viewed from the power end of the motor).
- Spring Return Motors are shipped from the factory in their normal position:
 - Normally closed models: shipped at limit of counterclockwise rotation, as viewed from the power end of the motor.

Adapter Bracket

The 220738A Adapter Bracket, positioned between the motor and the equipment, raises motor shaft height by 0.75 in. (19 mm) to match that of the former Modutrol Motor.

The following applications require this bracket:

- Q607 External Auxiliary Switch.
- Damper linkage applications require added clearance to allow:
 - crank arm rotation through the downward position.
 - sufficient damper linkage to reach the motor shaft.
- All valve linkages except the Q5001.

To mount the motor with the bracket (See Fig. 3):

1. Mount the bracket to the equipment with existing or standard bolts.
2. Using the provided bolts, mount the motor to the bracket threaded holes.

For valve linkage applications (other than the Q5001):

1. Mount the bracket to the linkage.
2. Position the motor on the bracket to align the motor shaft with the linkage.
3. Attach the motor to the bracket with the four bolts provided (See Fig. 4).

Damper Linkages

The motor does not include a crank arm. Order the crank arm, included in the Q605 Linkage, separately (refer to Accessories in the Specifications section). For detailed instructions on the assembly of specific linkages, refer to the instruction sheet packed with the linkage.



CAUTION

Equipment Damage Hazard.

Stalling a motor can damage the drive shaft.

Ensure installation of motors and linkages allows the motor to drive through full stroke without obstruction.

Valve Linkages

The Q100 Linkage requires the 220738A Adapter Bracket for all valve applications. Applications with the Q5001 Valve Linkage do not require the 220738A Adapter Bracket (Refer to Fig. 3).

Junction Box

When used with liquid-tight conduit connectors, the junction box provides NEMA 3 weather protection for the motor. The junction box, standard with replacement motors, encloses the terminals and provides knockouts for wiring conduits. Housing an internal transformer or internal auxiliary switches requires use of the junction box.

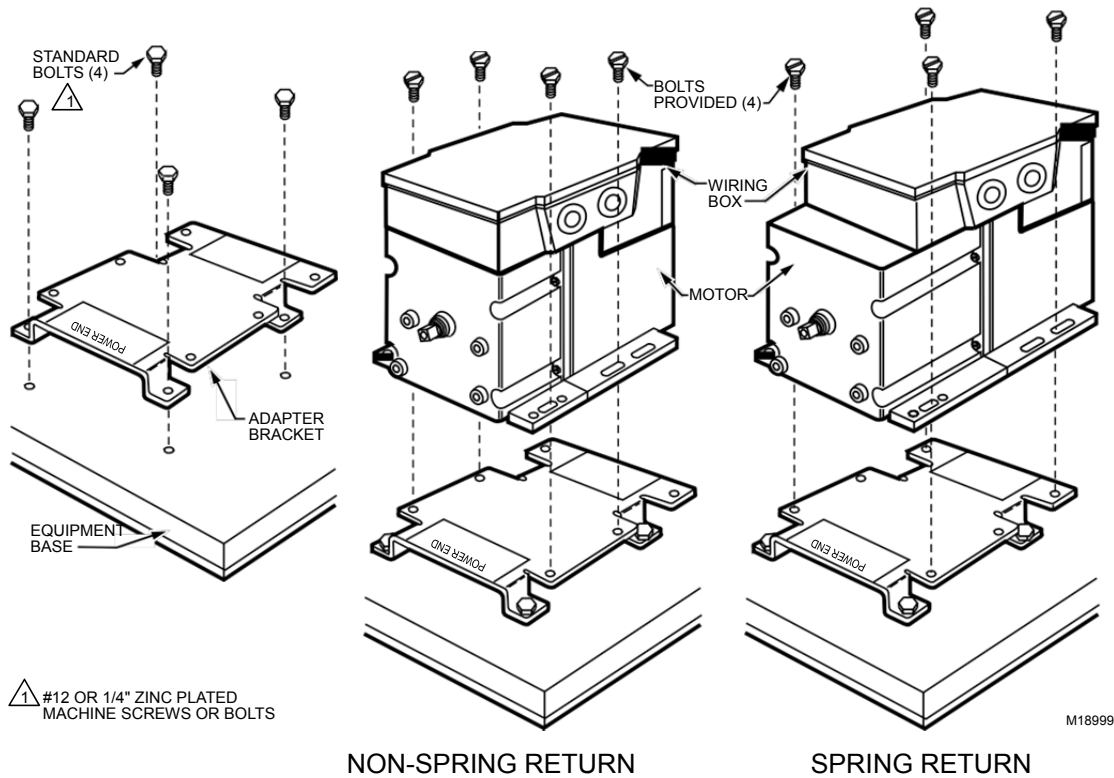

NON-SPRING RETURN

SPRING RETURN

NOTE: When no bracket is used in replacement applications, damper linkages require adjustment for the new shaft position.

Fig. 3. Mounting the Motor with an Adapter Bracket.

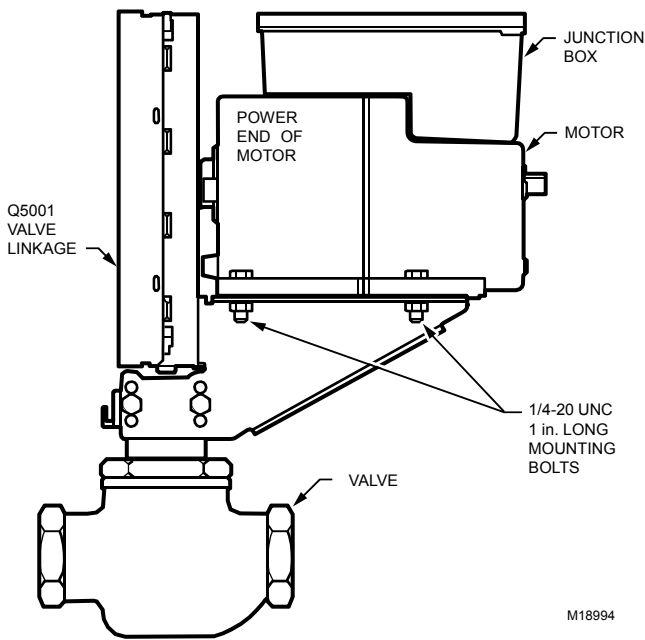

Fig. 4. Mounting the Motor on a Q5001 Valve Linkage.

WIRING



CAUTION

Electrical Shock or Equipment Damage Hazard.
Can shock individuals or short equipment circuitry.

Disconnect power supply before installation.

IMPORTANT

All wiring must agree with applicable codes, ordinances and regulations.

1. Ensure that the voltage and frequency stamped on the motor correspond to the power supply characteristics.
2. When connecting several motors in parallel, ensure that the power supply VA rating is large enough to provide power to all motors used without overloading.
3. Fig. 11 shows that the motor terminals are quick-connects located on top of the printed circuit board.
4. To access the wiring compartment:
 - a. Remove the four screws from the junction box top.
 - b. Lift off the cover.
5. Refer to Fig. 5 for typical wiring, and Fig. 7 for internal auxiliary switch connections.

NOTE: Reverse motor rotation by switching wires at either the motor or the panel. Reverse rotation on the Series 90 models by reversing the wires at terminals W and B.

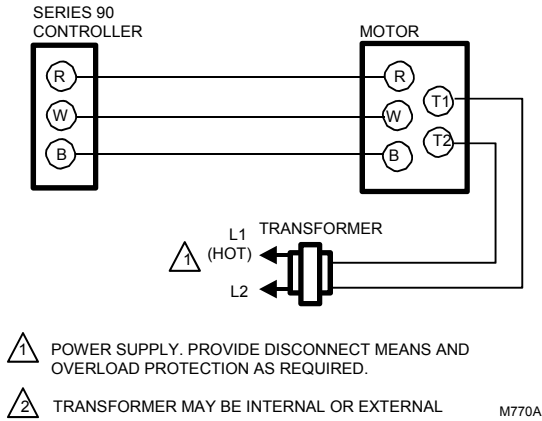

Fig. 5. Typical Series 90 Wiring.

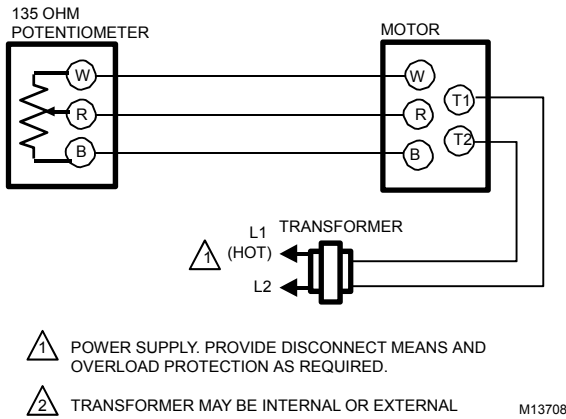

Fig. 6. Wiring for Potentiometer Control

For controlling up to six Series 90s in parallel with a 135 ohm pot or slide wire type series 90 controller, add the appropriate resistor indicated in the table below to ONE of the Series 90 motors, from terminal B to terminal W. As an alternative, one 221508A2 module can be used to provide any of the resistor values given below:

Table 7. Resistor Values of Motors in Parallel

Number of Motors in Parallel	Resistor Value
1	None
2	140 Ohms
3	72 Ohms
4	47 Ohms
5	36 Ohms
6	29 Ohms

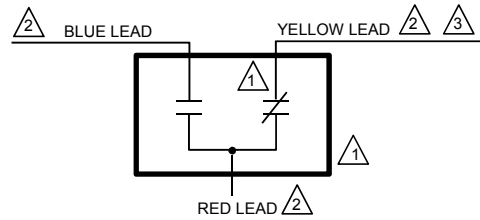

Fig. 7. Auxiliary Switch Schematic.

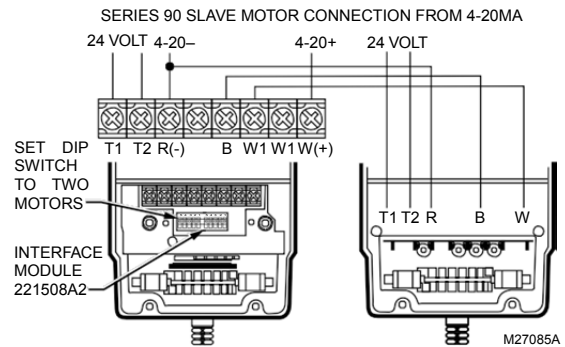

Fig. 8. Series 90 Slave Motor Connection.

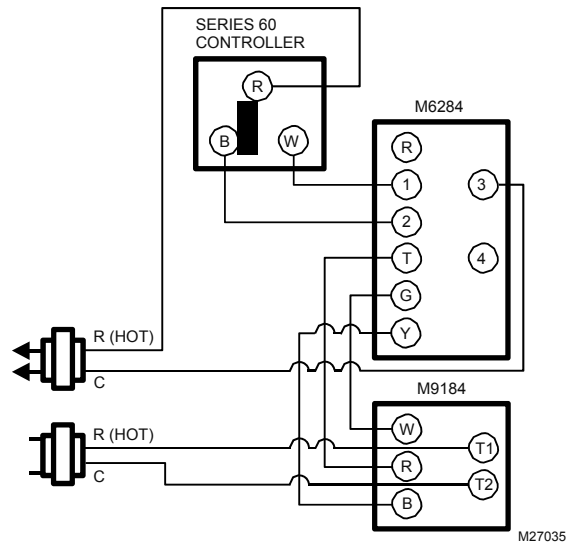

Fig. 9. Series 60 Controller.

The motors in the application need to be all symmetrical or all asymmetrical. The M62 motor needs to be a "-S" slaving model. In order to get the correct response the Series 62 needs the appropriate shunt resistor from Table 8. The motors' potentiometer settings are given in the configuration table (Table 9) below. When slaving more than one Series 90 motor use the appropriate resistor table as indicated by the configuration table and install two resistors to ONE of the motors (Tables 10 and 11). If the motor is the M62 master connect one resistor from terminals T to G and one from T to Y. If the motor is one of the M90 slaves connect one resistor from terminals R to B and one from R to W.

NOTE: More than 6 slaves is not recommended.

Table 8. Series 60 and Series 90 in Slaving Application

OS Number	Feedback Resistance	Sensitivity Adjustment	Internal Shunted	Linear Feedback	Series 90 Slaving Shunt Resistor
M6274F1009-F, M6284F1078-F, M6285F1001-F, M6294F1009-F, M6294F1017-F	10 K Ohms	No	No	Yes	Not Available
<i>"-S" Slaving Series 90 Mod IV Motor</i>	Not applicable for Europe				
<i>"-F" 0-10K Feedback</i>					

Table 9. Configuration Table

Symmetrical or Asymmetrical	Master Stroke	Slave Stroke	Master Stroke Pot	Master Sensitivity Pot	Slave Stroke Pot	Slave Sensitivity Pot	Resistor Table
Symmetrical	160	160	CW	CW	CW	CW	1
Symmetrical	90	90	CCW	CCW	CCW	CCW	2
Symmetrical	160	90	CCW	CW	CCW	CCW	1
Symmetrical	90	160	Configuration not recommended				
Asymmetrical	160	160	CW	CW	CW	CW	1
Asymmetrical	90	90	CCW	CW	CW	CW	1
Asymmetrical	160	90	Configuration not recommended				
Asymmetrical	90	160	Configuration not recommended				

Table 10. Resistor Table 1

Number of Motors in Parallel	Resistor Value
1	NONE
2	3500 Ohms
3	2000 Ohms
4	1300 Ohms
5	1000 Ohms
6	800 Ohms

Table 11. Resistor Table 2

Number of Motors in Parallel	Resistor Value
1	NONE
2	5000 Ohms
3	2400 Ohms
4	1700 Ohms
5	1400 Ohms
6	1200 Ohms

SETTINGS AND ADJUSTMENTS

Before Setting Stroke

1. Remove the top cover from the motor.
2. Disconnect the controller from the motor.
3. Connect a remote potentiometer to the motor as shown in Fig. 6 (R-W-B).



The stroke adjustment on the series 2 and series 3 motors is made using the **stroke and sensitivity** potentiometers located under the cove inside the motor. The stroke adjustment on a series 1 motor was made by adjusting the CAMS.

For Series 2 and Series 3 Motors:

To set the stroke to 160 degrees (maximum position) turn both stroke and sensitivity potentiometers fully clockwise , using a 1/8 inch straight-blade screwdriver.

To set the stroke to 90 degrees (minimum position) turn both stroke and sensitivity potentiometers fully counter-clockwise , using a 1/8 inch straight-blade screwdriver.

To set the stroke between 90 and 160 degrees:

1. Turn the **stroke and sensitivity** potentiometers fully clockwise, using a 1/8 inch straight-blade screwdriver.
2. Turn the **remote** potentiometer (previously installed on R-W-B terminals) to maximum position.
3. Turn the sensitivity potentiometer to the selected stroke (between 90 and 160 degrees) **OR** until the motor stops.
4. **IF** the motor stops before the selected stroke is reached, turn the **stroke** potentiometer until the selected stroke is reached **OR**
5. **IF** the selected stroke is reached using the sensitivity potentiometer, turn the **stroke** potentiometer counter-clockwise  until the motor begins to move. Then turn the **stroke** potentiometer clockwise  slightly to have the position correspond to the sensitivity potentiometer.
6. Make sure the minimum position is correct.

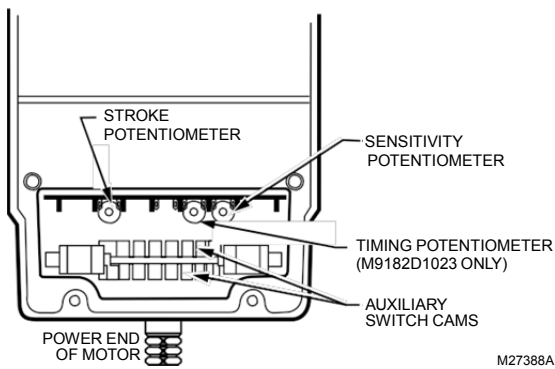

Fig. 10. Potentiometer Location and Stroke Adjustment Setup for Non-Spring Return Series 90 Motors.

CAUTION

Careless Installation Hazard.

Use of excessive force while adjusting cams damages the motor.

To avoid damaging motor end switches, set cams by moving only the top of the screwdriver.

CAUTION

Careless Installation Hazard.

Forcibly turning the motor shaft damages the gear train and stroke limit contacts.

Never turn motor shaft manually (either by hand or with a wrench).

CAUTION

Equipment Damage Hazard.

Can damage the motor beyond repair.

Set cams by moving the top of the screwdriver only. Pressing screwdriver against cam slot sides or use of excessive force can damage motor end switches.

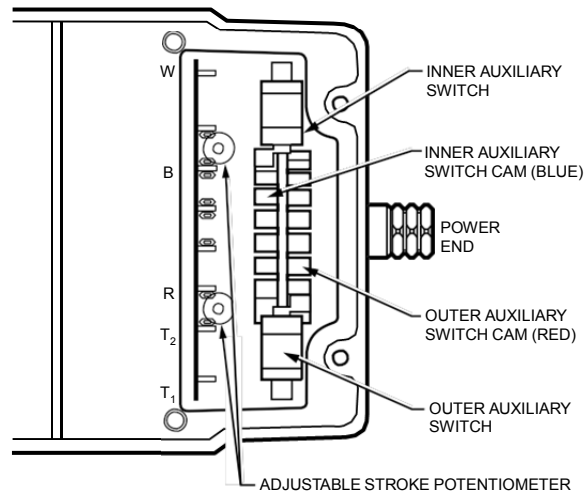

NOTE: NOT ALL FEATURES AVAILABLE ON ALL MODELS.

M31108A

Fig. 11. Terminals and Adjustments.

Auxiliary Switches

Adjustable cams actuate the auxiliary switches. These cams can be set to actuate the switches at any angle within the stroke of the motor. Select switch differential of 1° or 10°.

Motors with factory-added auxiliary switches are shipped in the closed position (fully counterclockwise, as viewed from the power end). Auxiliary cam default actuates the switches 30° from full open with a 1° differential. With the motor in the closed (fully counterclockwise) position, the auxiliary switch breaks contacts R-B. Refer to Fig. 7 (or the auxiliary switch Instruction Sheet) for auxiliary switch wiring.

NOTE: Auxiliary switches can only be added to motors that include auxiliary switch cams. (These cams cannot be field-added.)