

Features

- Interface for Power Rail
- Used for redundant configuration
- Supply current ≤ 4 A
- Replaceable fuse
- Relay contact output, reversible
- LED status indication

Function

The power feed module interfaces 24 V DC power to the Power Rail at a maximum current of 4 A and is designed for applications requiring redundant power. The twin input terminals allow for daisy-chaining of supply (max. 10 A).

A green LED on the front of the unit indicates that power is on, and a red LED illuminates during error conditions.

In the event of a field wiring or barrier fault from any barrier on the Power Rail, the integral collective error messaging relay alerts the controller via a single digital I/O point. This relay can be configured as normally open or normally closed.

Additionally, the bus implemented in the Power Rail is forwarded to the outside terminals 13 and 15 for usage with KFD2-WAC2-Ex1.D RS 485 connection. Terminal 14 is only for test purposes.

In the sense of functional safety (SIL) the device provides no dangerous failures. Thereby the safe condition of the supplied barrier must be defined as the powerless state. Thus the device will not influence the safety calculation or the SIL value.

This device is compatible with all versions of the Power Rail and provides group fusing.

Note: Redundant systems require two KFD2-EB.R4A.B modules.

Assembly

Front view

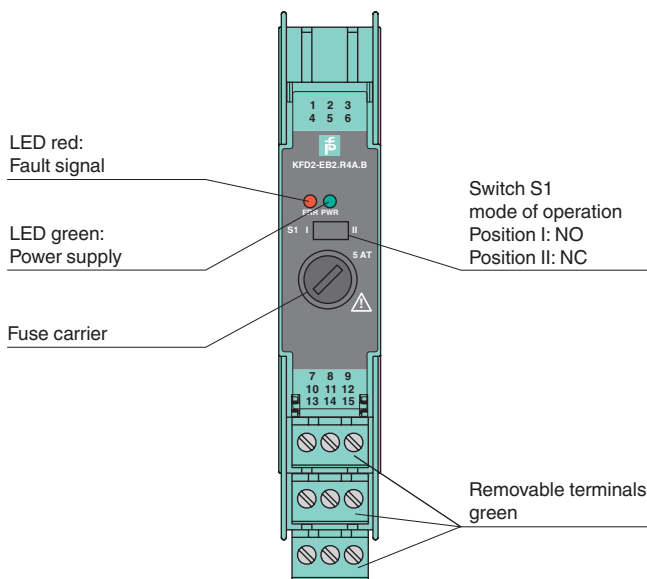

Connection

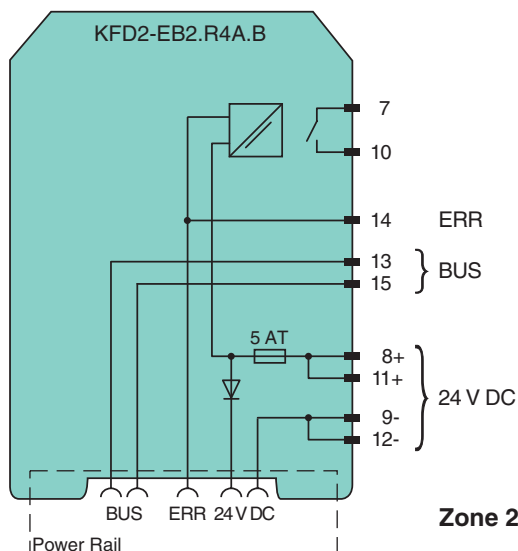

Release date 2016-05-23 12:04 Date of issue 2016-05-23 189784_eng.xml

Refer to "General Notes Relating to Pepperl+Fuchs Product Information".

Supply	
Connection	terminals 11+, 12- terminals 8+, 9-
Rated voltage U_n	20 ... 30 V DC The maximum rated operating voltage of the devices plugged onto the Power Rail must not be exceeded.
Power dissipation	≤ 2.4 W
Output	
Supply	Output current: ≤ 4 A
Fault signal	relay output: NO contact
Contact loading	30 V AC/ 2 A / $\cos \phi \geq 0.7$; 40 V DC/ 2 A
Energized/De-energized delay	approx. 20 ms / approx. 20 ms
Fuse rating	5 A recommended maximum utilization of the fuse: 80 %
Directive conformity	
Electromagnetic compatibility	
Directive 2014/30/EU	EN 61326-1:2013 (industrial locations)
Conformity	
Electromagnetic compatibility	NE 21:2006
Degree of protection	IEC 60529:2001
Ambient conditions	
Ambient temperature	-20 ... 60 °C (-4 ... 140 °F)
Mechanical specifications	
Degree of protection	IP20
Mass	approx. 100 g
Dimensions	20 x 119 x 115 mm (0.8 x 4.7 x 4.5 in) , housing type B2
Mounting	on 35 mm DIN mounting rail acc. to EN 60715:2001
Data for application in connection with Ex-areas	
Statement of conformity	TÜV 00 ATEX 1618 X
Group, category, type of protection, temperature class	⊕ II 3G Ex nA nC IIC T4
Directive conformity	
Directive 2014/34/EU	EN 60079-0:2012+A11:2013 , EN 60079-15:2010
International approvals	
FM approval	
Control drawing	116-0160
Approved for	Class I, Division 2, Groups A, B, C, D; Class I, Zone 2, IIC
UL approval	
Approved for	Class I, Division 2, Groups A, B, C, D; Class I, Zone 2, IIC
CSA approval	
Control drawing	116-0160
Approved for	Class I, Division 2, Groups A, B, C, D; Class I, Zone 2, IIC
IECEX approval	IECEX UL 16.0051
Approved for	Ex nA nC IIC T4 Gc
General information	
Supplementary information	Statement of Conformity, Declaration of Conformity, Attestation of Conformity and instructions have to be observed where applicable. For information see www.pepperl-fuchs.com .

Release date 2016-05-23 12:04 Date of issue 2016-05-23 189784_eng.xml

Accessories

Power feed module KFD2-EB2

The power feed module is used to supply the devices with 24 V DC via the Power Rail. The fuse-protected power feed module can supply up to 150 individual devices depending on the power consumption of the devices. Collective error messages received from the Power Rail activate a galvanically-isolated mechanical contact.

Power Rail UPR-03

The Power Rail UPR-03 is a complete unit consisting of the electrical insert and an aluminium profile rail 35 mm x 15 mm. To make electrical contact, the devices are simply engaged.

Profile Rail K-DUCT with Power Rail

The profile rail K-DUCT is an aluminum profile rail with Power Rail insert and two integral cable ducts for system and field cables. Due to this assembly no additional cable guides are necessary.



Power Rail and Profile Rail must not be fed via the device terminals of the individual devices!