

IG-028

Sensor Head



SPECIFICATIONS

Model	IG-028	
Operation principle	CCD method	
Light source	Wavelength	660 nm (Visible light semiconductor laser)
	FDA	Class 1 ^{*1}
	IEC/JIS	Class 1
Mounting distance	0 to 1500 mm	
Measurement range	28 mm	
Sampling cycle	980 μs (When the number of times for averaging is set to [hsp]: 490 μs)	
Minimum detectable object	High sensitivity mode	ø0.1 mm (Setting distance: 100 mm) ^{*2}
	Standard mode	ø0.2 mm (Setting distance: 50 mm), ø0.5 mm (Setting distance: 500 mm) ^{*2}
Repeatability	5 μm (Setting distance: 100 mm) 10 μm (Setting distance: 500 mm) 80 μm (Setting distance: 1,000 mm) 140 μm (Setting distance: 1,500 mm) ^{*3}	
Linearity	±0.1 % of F.S. (±28 μm) ^{*4}	
Temperature characteristics	±0.01 % of F.S./°C (±3 μm/°C) ^{*5}	
Operation indicator	Transmitter	Optical axis alignment indicator: Green LED Power indicator: Green LED
	Receiver	Optical axis alignment indicator: Green LED Position monitor: Dual bar LED (Red, Green)
Environmental resistance	Enclosure rating	IP67
	Ambient light	Incandescent lamp: 5,000 lux, Sunlight: 5,000 lux ^{*6}
	Ambient temperature	-10 to +45 °C (No freezing)
	Relative humidity	35 to 85 % RH (No condensation)
	Vibration resistance	10 to 55 Hz, Double amplitude 1.5 mm, 2 hours in each of the X, Y, and Z axis
Material	Case	Zinc die-cast (Lower case), PBT (Upper case), Polyarylate (PAR) (Display part), SUS304 (Metallic part)
	Lens cover	Glass
	Cable	PVC
Accessories	Transmitter × 1, Receiver × 1, Sensor head cables (2 m) × 2	
Weight	Approx. 500 g (including supplied items)	

^{*1} The classification for FDA (CDRH) is implemented based on IEC60825-1 in accordance with the requirements of Laser Notice No.50.

^{*2} When the measurement target object is measured at the centre position of the setting distance.

When the measurement mode is set to the glass edge mode, a glass edge of C0.1 mm or more can be detected (Setting distance: 500 mm).

^{*3} When the light is shielded by half at the centre position of the setting distance. Vibration width when the average number of times is set to 16 and sampling is performed for 30 seconds. (When the analogue output is used, the margin of error of analogue output is added.)

^{*4} When the setting distance is 100 mm and light is shielded at 50 mm position from the receiver. Margin of error to the ideal line.

^{*5} When the setting distance is 100 mm and light is shielded by half at 50 mm position from the receiver.

^{*6} Excluding when the average number of times is set to [hsp].

Dimensions

* Download CAD file or product manual for larger image/text and more detail.

IG-028

unit: r

■ Transmitter

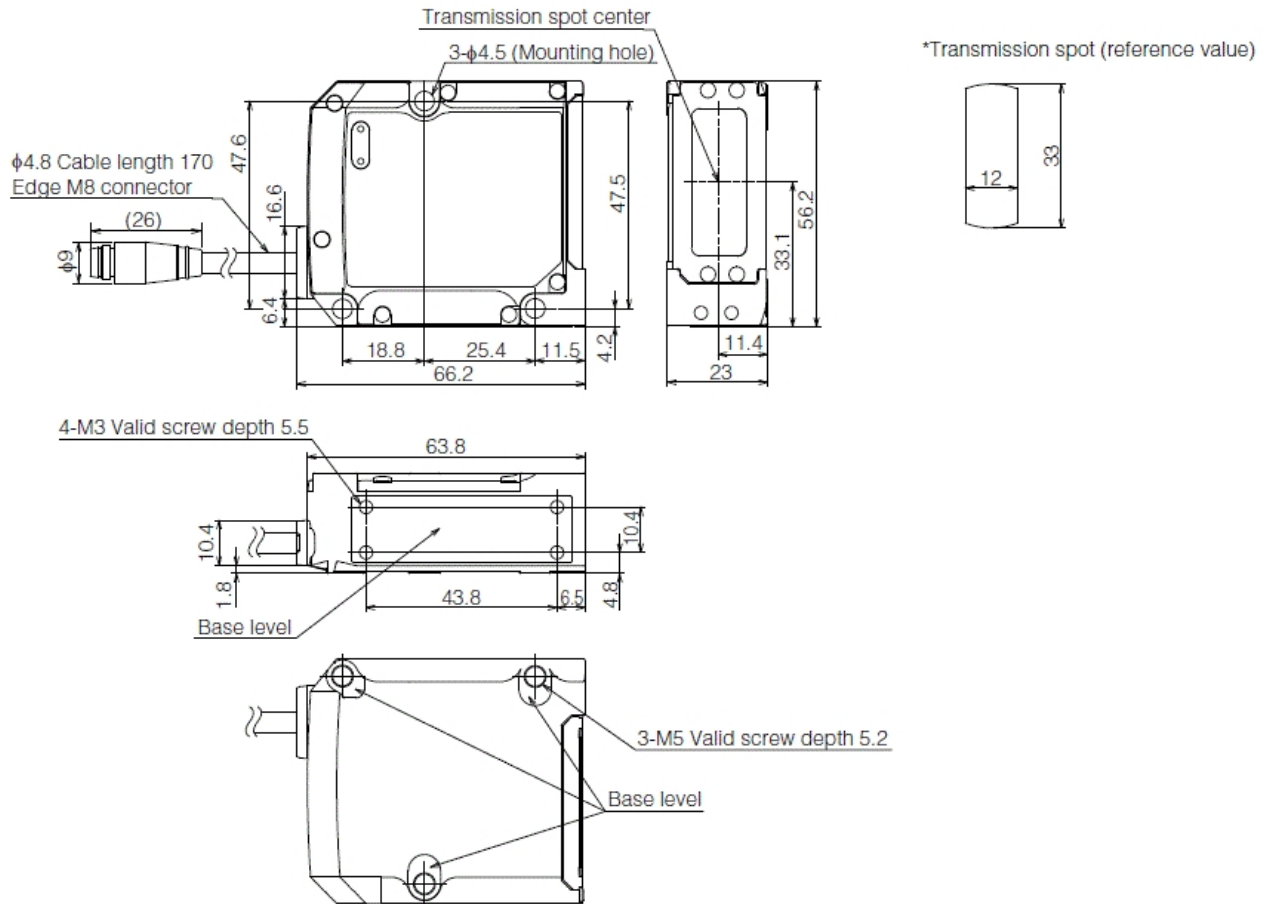

■ Receiver

