



General-Purpose AC Servo

MELSERVO

MODEL

HF-MP

HF-KP

HF-SP

HA-LP

HC-RP

HC-UP

HC-LP

HF-JP

HG-AK

SERVO MOTOR INSTRUCTION MANUAL (Vol.2)

6. HF-MP SERIES · HF-KP SERIES

Model	Output [W]	Brake static friction torque [N · m] ([oz · in])	Inertia moment J [$\times 10^{-4}$ kg · m ²] (WK ² [oz · in ²])	Mass [kg] ([lb])
HF-MP73B	750	2.4 (340)	0.70 (3.83)	3.9 (8.60)
HF-KP73B	750	2.4 (340)	1.63 (8.91)	3.9 (8.60)

[Unit: mm]

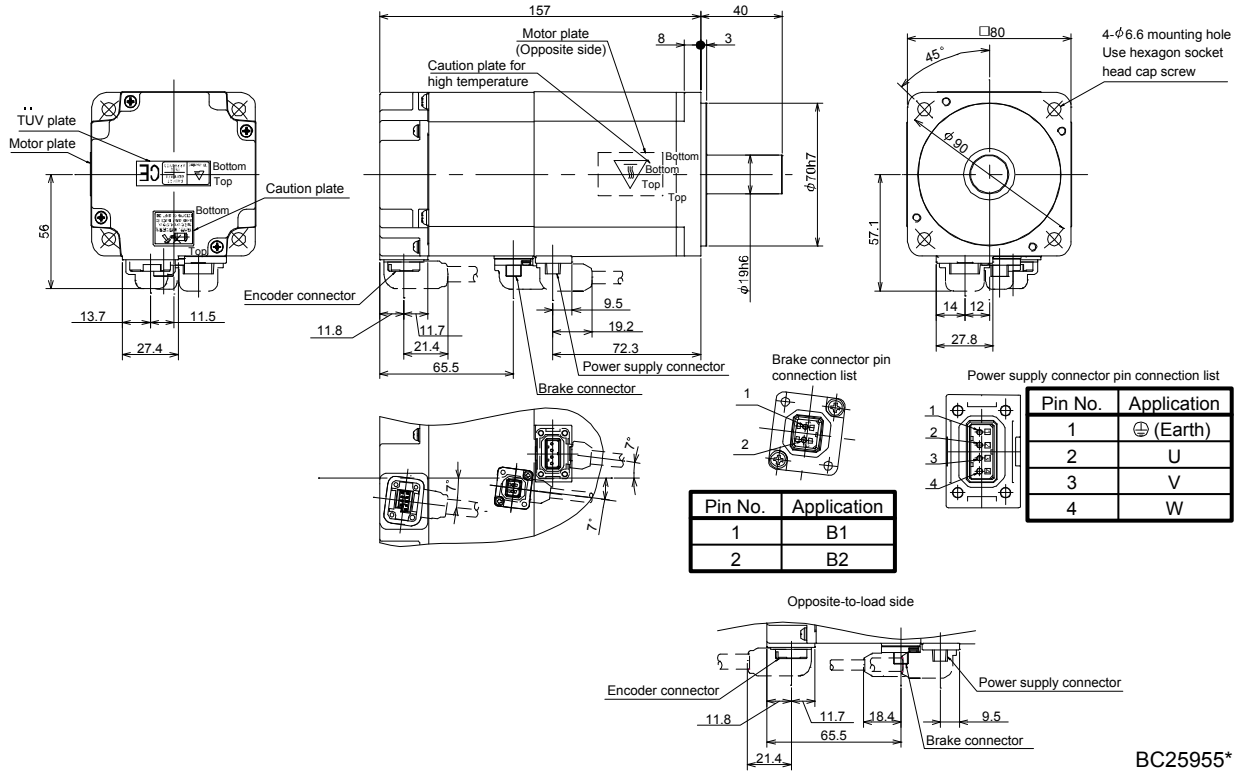

BC25955*