



General-Purpose AC Servo

MELSERVO

MODEL

HF-MP

HF-KP

HF-SP

HA-LP

HC-RP

HC-UP

HC-LP

HF-JP

HG-AK

SERVO MOTOR INSTRUCTION MANUAL (Vol.2)

6. HF-MP SERIES • HF-KP SERIES

Model	Output [W]	Inertia moment J [$\times 10^{-4}$ kg · m ²] (WK ² [oz · in ²])	Mass [kg] ([lb])
HF-MP43	400	0.15 (0.82)	1.5 (3.31)
HF-KP43	400	0.42 (2.30)	1.5 (3.31)

[Unit: mm]

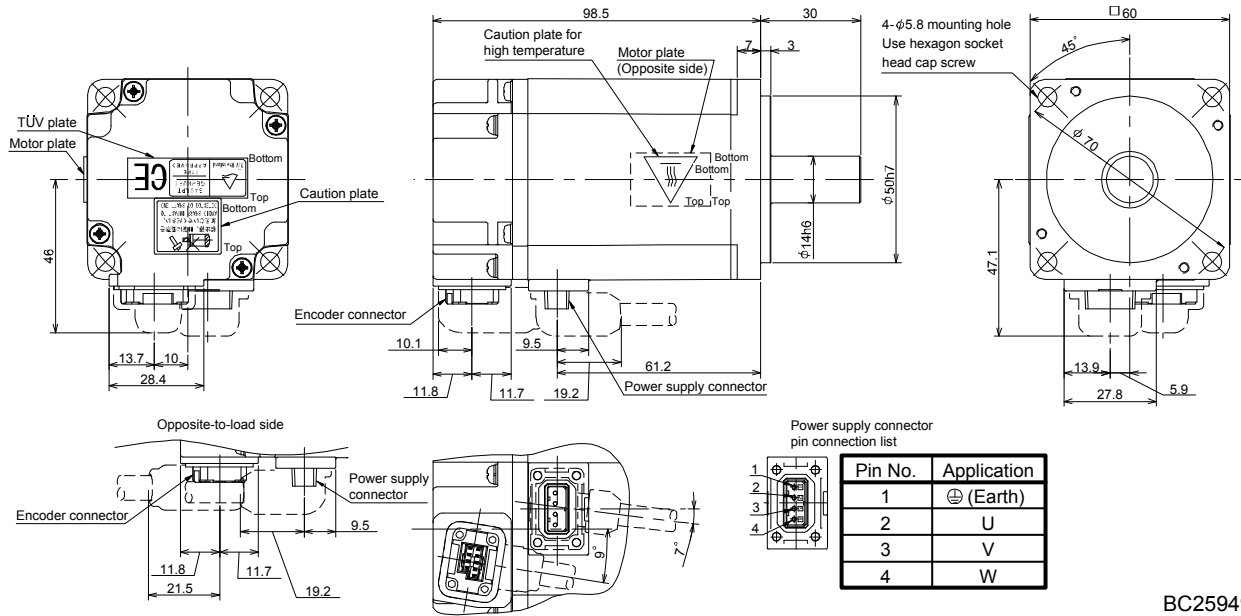

BC25949*

Model	Output [W]	Inertia moment J [$\times 10^{-4}$ kg · m ²] (WK ² [oz · in ²])	Mass [kg] ([lb])
HF-MP73	750	0.60 (3.28)	2.9 (6.39)
HF-KP73	750	1.43 (7.82)	2.9 (6.39)

[Unit: mm]

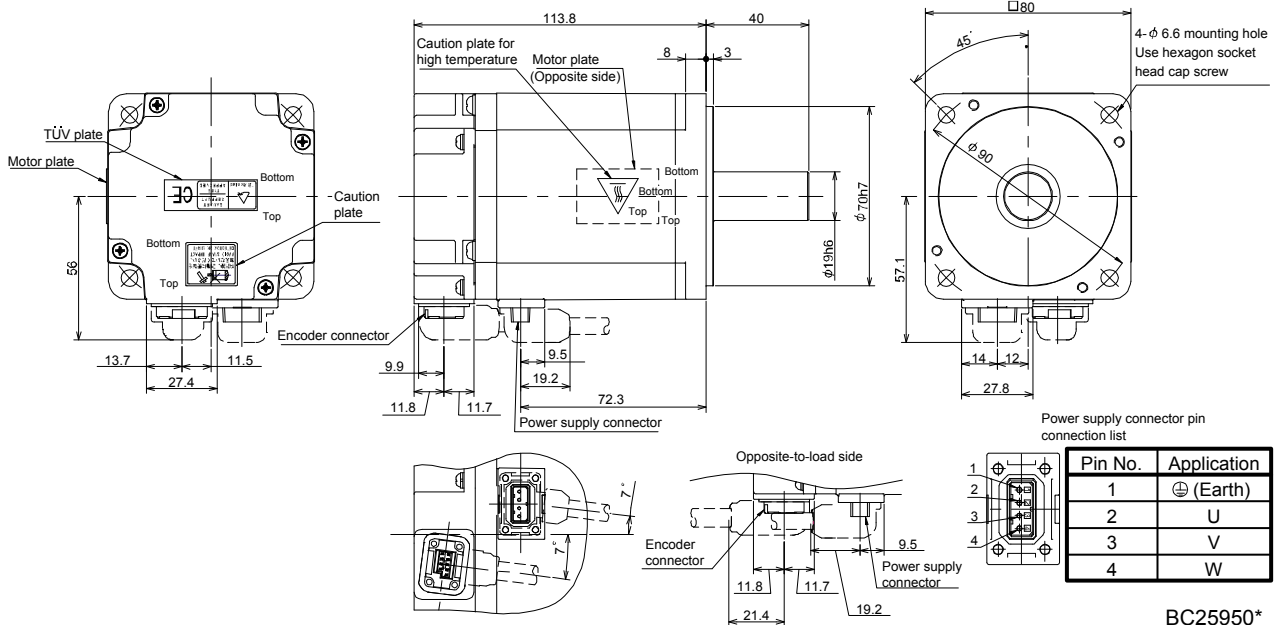

BC25950*