



GV-H45

Sensor Head Short-distance Type

CE

Specifications

Model		GV-H45	
Type		Short-range	
Light source		Visible semiconductor laser, Wavelength: 655 nm	
Laser class	FDA (CDRH) Part 1040.10	Class 2 (560 μ W)	
	IEC 60825-1		
	JIS C6802		
Detection distance (Amplifier display)		20 to 45 mm 0.79" to 1.77" (250 to 0)*1)	
Possible display range		259 to -34	
Standard detection deviation		0.5 mm 0.02"	
Spot diameter		Approx. \varnothing 0.1 mm \varnothing0.004" (Detection distance 45 mm 1.77")	
Operation status indicators		Control output: Red LED/Laser radiation emission indicator: Green LED/1 spot indicator: Green LED	
Environmental resistance	Enclosure rating		IP67
	Operating ambient luminance	Incandescent lamp	10000lx
		Sunlight	20000lx
	Ambient temperature		-10 to +50 °C 14 to 122 °F (No freezing)
	Relative humidity		35 to 85 % RH (No condensation)
Vibration resistance		10 to 55 Hz, Double amplitude 1.5 mm 0.06" , 2 hours in each of the X, Y, and Z axis	
Material		Housing material: PBT, Display: Polyarylate, Metal: SUS304, Lens cover: Glass, Cable: PVC	
Weight		Approx. 120 g*2	

*1 General guideline for amplifier display values relative to detection distance (when distance display mode is set to normal).

*2 Including 2 m **6.6'** connector cable (3 m **9.8'** cable for GV-H1000)

Dimensions

* Download CAD file or product manual for larger image/text and more detail.

SENSOR HEAD GV-H45/GV-H45L

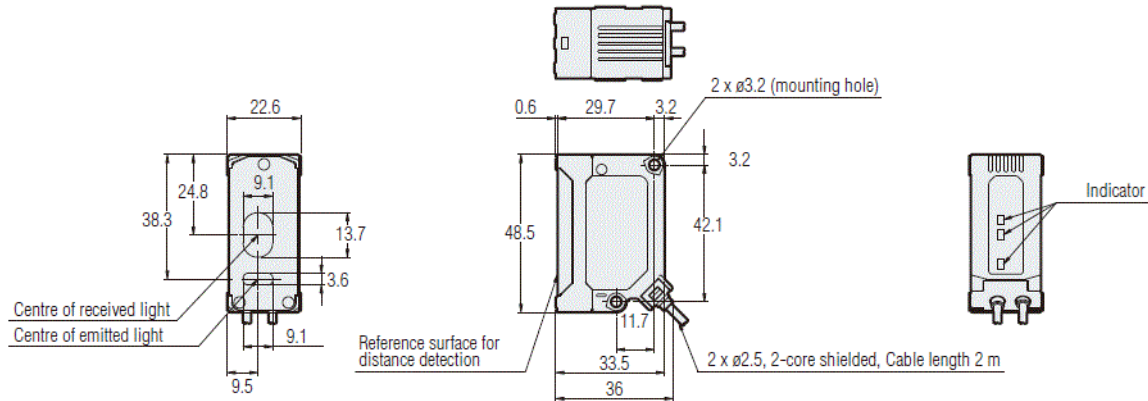

Mounting bracket (accessory)

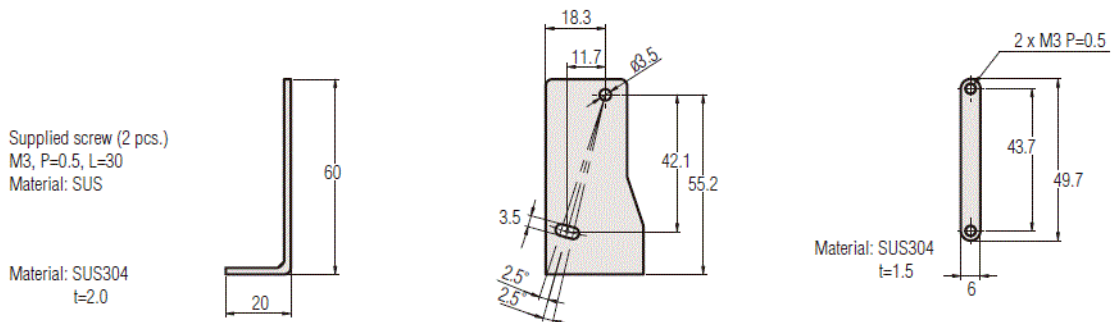

Insulation sheet (accessory) When the insulation sheet is attached

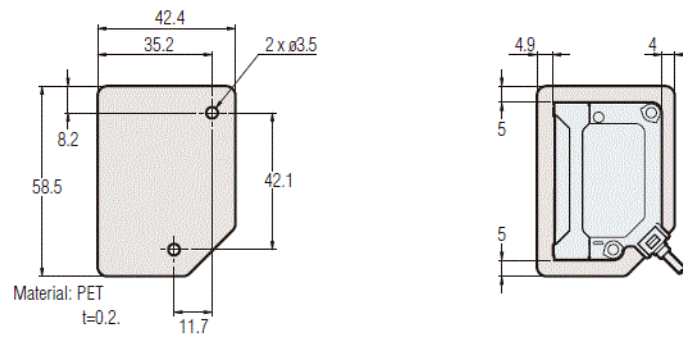

When the mounting bracket is attached

