



Measuring instrument AM72

Type 413 85

Type 413 84

Technical data

Ex-control stations Type 413 84 | Type 413 85

Marking accd. to 94/9/EC	II 2 G Ex ed ibm IIC T6 II 2 D Ex tD A21 IP66 T80 °C	
EC-Type Examination Certificate	PTB 00 ATEX 3117	
IECEX Certificate of Conformity	IECEX BKI 04.0003	
Marking accd. to IECEx	Ex e II T6, Ex e ib IIC T6, Ec ed IIC T6 or Ex ed ib IIC T6	
Permissible ambient temperature	-20 °C up to +40 °C -55 °C up to +55 °C (option)	
Rated voltage	690 V AC (with control switch GHG 23 to 500 V)	
Rated current	16 A (with control switch GHG 23 max. 10 A)	
Rated making-/rated breaking capacity accd. EN 60947-5-1	Ex41 AC-15: U _o 250 V / I _o 6 A U _o 500 V / I _o 4 A DC-13: U _o 24 V / I _o 6 A U _o 220 V / I _o 1 A	Ex23 AC-15: U _o 230 V / I _o 6 A U _o 500 V / I _o 4 A DC-13: U _o 24 V / I _o 2 A U _o 230 V / I _o 0.5 A
Connecting terminals	2 x 4 mm ²	
Protection class	I	
Degree of protection accd. to EN 60529	IP66	
Cable glands/Gland plates/Enclosure drilling	1 x M20 threaded entry	
Enclosure material	High quality cast aluminium (AlSi)	
Enclosure colour	grey RAL 7031	

Type 413 84

Dimensions (L x W x H)	122 x 120 x 81 mm
Weight (empty)	0.85 kg

Type 413 85

Dimensions (L x W x H)	220 x 120 x 81 mm
Weight (empty)	1.45 kg

Type 413 84 with measuring instrument AM 72

Movement	Moving iron	Moving coil
Marking accd. to 94/9/EC	II G Ex e II	II G Ex ib IIC
Accuracy	Class 2.5	Class 1.5
Overload range	10-fold -25 sec. 25-fold - 4 sec. 50-fold - 1 sec. indicated 1:1.5, optional 1:6, 1:10	10-fold -5 sec.
Measuring range	n / 1A 0 - 25 A direct	0 - 20 mA 4 - 20 mA
Inductance L _i	-	≤ 0.1 mH
Capacitance C _i	-	≤ 0.1 nF
Open circuit voltage max. U _i	-	30 V
Short circuit current max. I _i	-	150 mA
Connecting terminals	2 x 1.5 - 4 mm ²	
Weight	1.25 kg	

¹⁾ Base enclosure can be rotated after wards (entry from top or down)

Other versions available on request

Ex-control stations



Type 413 84...01



Type 413 84...02



Type 413 84...03



Type 413 84...04

4

Ordering details Type 413 84 with 2 built-in components

Content	Built-in components	Weight approx.	Order No.
	2 x pushbutton DRT 1 NO + 1 NC each label: "0, I, START, STOP"	1.25 kg	GHG 413 8400 R0001
	1 x signal lamp SIL 20-250 V AC/DC coloured lens cover: „white, red, green, yellow“ 1 x double pushbutton DDT 1 NO + 1 NC label: "0, I, START, STOP"	1.30 kg	GHG 413 8400 R0002
	1 x double pushbutton DDT 1 NO + 1 NC label: "0, I, START, STOP" 1 x mushroom-head pushbutton SGTE 1 NO + 1 NC "emergency stop"	1.30 kg	GHG 413 8400 R0003
	1 x measuring instrument AM45 CT connection n/1A Scale 0 –100%/150% 1 x double pushbutton DDT 1 NO + 1 NC label: "0, I, START, STOP"	1.35 kg	GHG 413 8400 R0004



Type 413 85...03

Type 413 85...02

Type 413 85...01

Ordering details Type 413 85 with 4 built-in components

Content	Built-in components	Weight approx.	Order No.
<p>X1—⊗—X2</p>	<p>1 x signal lamp SIL 20-250 V AC/DC coloured lens cover: „white, red, green, yellow“ 2 x pushbutton DRT 1 NO + 1 NC label: “0, I, START, STOP” 1 x mushroom-head pushbutton SGTE 1 NO + 1 NC “emergency stop”</p>	2.10 kg	GHG 413 8500 R0001
<p>X1—⊗—X2</p>	<p>2 x signal lamp SIL 20-250 V AC/DC coloured lens cover: „white, red, green, yellow“ 2 x double pushbutton DDT 1 NO + 1 NC label: “0, I, START, STOP”</p>	2.10 kg	GHG 413 8500 R0002
<p>X1—⊗—X2</p>	<p>1 x signal lamp SIL 20-250 V AC/DC coloured lens cover: „white, red, green, yellow“ label: “I 0 II” 1 x double pushbutton DDT 1 NO + 1 NC label: “0, I, START, STOP” 1 x mushroom-head pushbutton SGTE 1 NO + 1 NC “emergency stop” 1 x key-operated switch 2 NO SW 5 “engaging-engaging-engaging” label: “I 0 II”</p>	2.20 kg	GHG 413 8500 R0003

Ex-control stations



Measuring instrument AM72

4

Ordering details Type 413 84 with measuring instrument AM72

Content Movement	Weight approx.	Order No.	
Version direct measurement with 1 x threaded entry M20			
0 - 1 / 1.5 A	Moving iron	1.25 kg	GHG 413 8481 R0002
0 - 2.5 / 3.75 A	Moving iron	1.25 kg	GHG 413 8481 R0003
0 - 5 / 7.5 A	Moving iron	1.25 kg	GHG 413 8481 R0004
0 - 10 / 15 A	Moving iron	1.25 kg	GHG 413 8481 R0005
0 - 16 / 24 A	Moving iron	1.25 kg	GHG 413 8481 R0007
0 - 20 / 24 mA 0-100% / 120% (Ri =320 Ω)	Moving coil	1.35 kg	GHG 413 8481 R0033
4 - 20 / 24 mA 0-100% / 120% (Ri =320 Ω)	Moving coil	1.35 kg	GHG 413 8481 R0035
Version CT connection n/1A with 1 x threaded entry M20			
0 - 1 / 1.5 A	Moving iron	1.25 kg	GHG 413 8482 R0002
0 - 2.5 / 3.75 A	Moving iron	1.25 kg	GHG 413 8482 R0003
0 - 5 / 7.5 A	Moving iron	1.25 kg	GHG 413 8482 R0004
0 - 10 / 15 A	Moving iron	1.25 kg	GHG 413 8482 R0005
0 - 15 / 22.5 A	Moving iron	1.25 kg	GHG 413 8482 R0007
0 - 20 / 30 A	Moving iron	1.25 kg	GHG 413 8482 R0008
0 - 30 / 45 A	Moving iron	1.25 kg	GHG 413 8482 R0009
0 - 40 / 60 A	Moving iron	1.25 kg	GHG 413 8482 R0010
0 - 50 / 75 A	Moving iron	1.25 kg	GHG 413 8482 R0011
0 - 60 / 90 A	Moving iron	1.25 kg	GHG 413 8482 R0012
0 - 75 / 112.5 A	Moving iron	1.25 kg	GHG 413 8482 R0013
0 - 100 / 150 A	Moving iron	1.25 kg	GHG 413 8482 R0014
0 - 100% / 150%	Moving iron	1.25 kg	GHG 413 8482 R0033

Dimension drawing

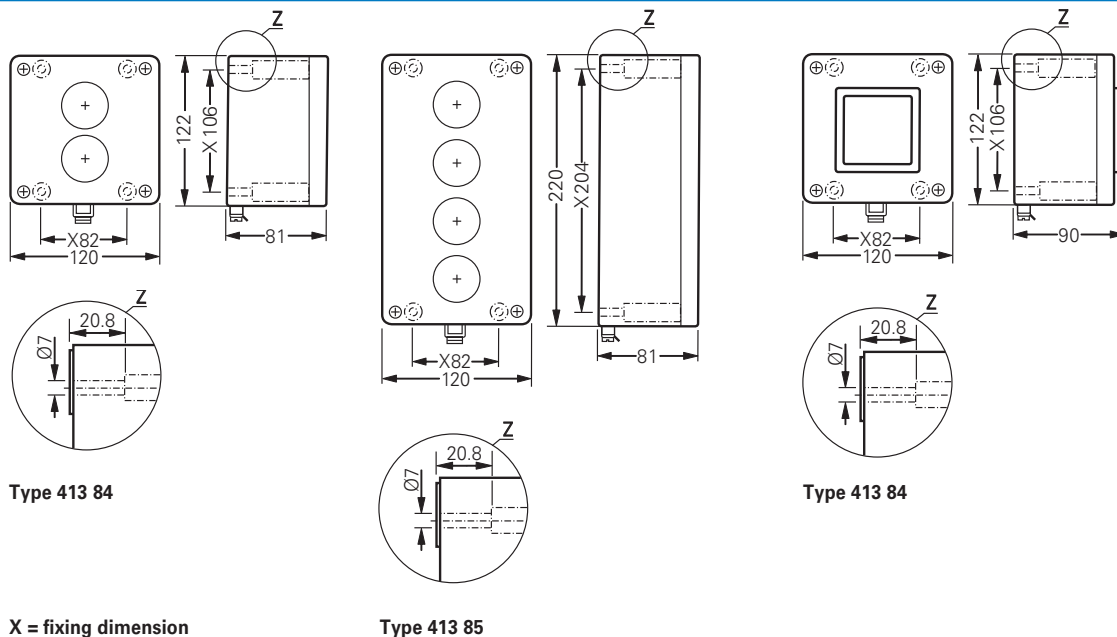

Dimensions in mm



Measuring instrument AM72



Type 413 85



Type 413 84

Technical data

Ex-control stations Type 413 84 | Type 413 85

Marking accd. to 2014/34/EU	Ⓢ II 2 G Ex ed ibm IIC T6 Ⓢ II 2 D Ex tD A21 IP66 T80 °C	
EC-Type Examination Certificate	PTB 00 ATEX 3117	
IECEX Certificate of Conformity	IECEX BKI 04.0003	
Marking accd. to IECEx	Ex e II T6, Ex e ib IIC T6, Ec ed IIC T6 or Ex ed ib IIC T6	
Permissible ambient temperature	-20 °C up to +40 °C -55 °C up to +55 °C (option)	
Rated voltage	690 V AC (with control switch GHG 23 to 500 V)	
Rated current	16 A (with control switch GHG 23 max. 10 A)	
Rated making-/rated breaking capacity accd. EN 60947-5-1	Ex41 AC-15: U_g 250 V / I_g 6 A U_g 500 V / I_g 4 A DC-13: U_g 24 V / I_g 6 A U_g 110 V / I_g 0.8 A	Ex23 AC-15: U_g 230 V / I_g 6 A U_g 500 V / I_g 4 A DC-13: U_g 24 V / I_g 2 A U_g 230 V / I_g 0.5 A
Connecting terminals	2 x 4 mm ²	
Protection class	I	
Degree of protection accd. to EN 60529	IP66	
Cable glands/Gland plates/Enclosure drilling	1 x M20 threaded entry	
Enclosure material	High quality cast aluminium (AlSi)	
Enclosure colour	grey RAL 7031	

Type 413 84

Dimensions (L x W x H)	122 x 120 x 81 mm
Weight (empty)	0.85 kg

Type 413 85

Dimensions (L x W x H)	220 x 120 x 81 mm
Weight (empty)	1.45 kg

Type 413 84 with measuring instrument AM 72

Movement	Moving iron	Moving coil
Marking accd. to 2014/34/EU	Ⓢ II G Ex e II	Ⓢ II G Ex ib IIC
Accuracy	Class 2.5	Class 1.5
Overload range	10-fold -25 sec. 25-fold - 4 sec. 50-fold - 1 sec. indicated 1:1.5, optional 1:6, 1:10	10-fold -5 sec.
Measuring range	n / 1A 0 - 25 A direct	0 - 20 mA 4 - 20 mA
Inductance L_i	–	≤ 0.1 mH
Capacitance C_i	–	≤ 0.1 nF
Open circuit voltage max. U_i	–	30 V
Short circuit current max. I_i	–	150 mA
Connecting terminals	2 x 1.5 - 4 mm ²	
Weight	1.25 kg	

¹⁾ Base enclosure can be rotated after wards (entry from top or down)

Other versions available on request

Ex-light metal control stations GHG 413 84



Type 413 84...01



Type 413 84...02



Type 413 84...03



Type 413 84...04

4 Ordering details Type 413 84 with 2 built-in components

Content	Built-in components	Weight approx.	Order No.
	2 x pushbutton DRT 1 NO + 1 NC each label: "0, I, START, STOP"	1.25 kg	GHG 413 8400 R0001
X1 — — X2 	1 x signal lamp SIL 20-250 V AC/DC coloured lens cover: „white, red, green, yellow“ 1 x double pushbutton DDT 1 NO + 1 NC label: "0, I, START, STOP"	1.30 kg	GHG 413 8400 R0002
	1 x double pushbutton DDT 1 NO + 1 NC label: "0, I, START, STOP" 1 x mushroom-head pushbutton SGTE 1 NO + 1 NC "emergency stop"	1.30 kg	GHG 413 8400 R0003
1 — — 2 	1 x measuring instrument AM45 CT connection n/1A Scale 0 – 100%/150% 1 x double pushbutton DDT 1 NO + 1 NC label: "0, I, START, STOP"	1.35 kg	GHG 413 8400 R0004



Type 413 85...03



Type 413 85...02



Type 413 85...01

Ordering details Type 413 85 with 4 built-in components

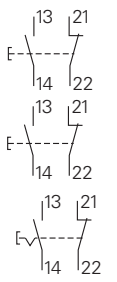
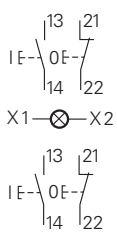
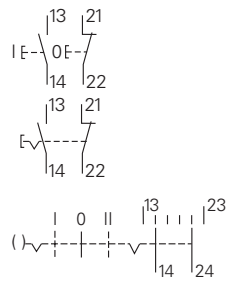
Content	Built-in components	Weight approx.	Order No.
<p>X1—⊗—X2</p> 	<p>1 x signal lamp SIL 20-250 V AC/DC coloured lens cover: „white, red, green, yellow“ 2 x pushbutton DRT 1 NO + 1 NC label: “0, I, START, STOP” 1 x mushroom-head pushbutton SGTE 1 NO + 1 NC “emergency stop”</p>	2.10 kg	GHG 413 8500 R0001
<p>X1—⊗—X2</p> 	<p>2 x signal lamp SIL 20-250 V AC/DC coloured lens cover: „white, red, green, yellow“ 2 x double pushbutton DDT 1 NO + 1 NC label: “0, I, START, STOP”</p>	2.10 kg	GHG 413 8500 R0002
<p>X1—⊗—X2</p> 	<p>1 x signal lamp SIL 20-250 V AC/DC coloured lens cover: „white, red, green, yellow“ label: “I 0 II” 1 x double pushbutton DDT 1 NO + 1 NC label: “0, I, START, STOP” 1 x mushroom-head pushbutton SGTE 1 NO + 1 NC “emergency stop” 1 x key-operated switch 2 NO SW 5 “engaging-engaging-engaging” label: “I 0 II”</p>	2.20 kg	GHG 413 8500 R0003

Ex-light metal control stations GHG 413 84



Measuring instrument AM72

4 Ordering details Type 413 84 with measuring instrument AM72

Content	Movement	Weight approx.	Order No.
Version direct measurement with 1 x threaded entry M20			
0 – 1 / 1.5 A	Moving iron	1.25 kg	GHG 413 8481 R0002
0 - 2.5 / 3.75 A	Moving iron	1.25 kg	GHG 413 8481 R0003
0 - 5 / 7.5 A	Moving iron	1.25 kg	GHG 413 8481 R0004
0 - 10 / 15 A	Moving iron	1.25 kg	GHG 413 8481 R0005
0 - 16 / 24 A	Moving iron	1.25 kg	GHG 413 8481 R0007
0 - 20 / 24 mA 0-100% / 120% (Ri =320 Ω)	Moving coil	1.35 kg	GHG 413 8481 R0033
4 - 20 / 24 mA 0-100% / 120% (Ri =320 Ω)	Moving coil	1.35 kg	GHG 413 8481 R0035

Version CT connection n/1A with 1 x threaded entry M20

0 – 1 / 1.5 A	Moving iron	1.25 kg	GHG 413 8482 R0002
0 - 2.5 / 3.75 A	Moving iron	1.25 kg	GHG 413 8482 R0003
0 - 5 / 7.5 A	Moving iron	1.25 kg	GHG 413 8482 R0004
0 - 10 / 15 A	Moving iron	1.25 kg	GHG 413 8482 R0005
0 - 15 / 22.5 A	Moving iron	1.25 kg	GHG 413 8482 R0007
0 - 20 / 30 A	Moving iron	1.25 kg	GHG 413 8482 R0008
0 - 30 / 45 A	Moving iron	1.25 kg	GHG 413 8482 R0009
0 - 40 / 60 A	Moving iron	1.25 kg	GHG 413 8482 R0010
0 - 50 / 75 A	Moving iron	1.25 kg	GHG 413 8482 R0011
0 - 60 / 90 A	Moving iron	1.25 kg	GHG 413 8482 R0012
0 - 75 / 112.5 A	Moving iron	1.25 kg	GHG 413 8482 R0013
0 - 100 / 150 A	Moving iron	1.25 kg	GHG 413 8482 R0014
0 – 100% / 150%	Moving iron	1.25 kg	GHG 413 8482 R0033

Dimension drawing

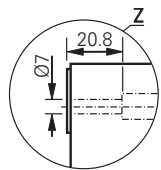
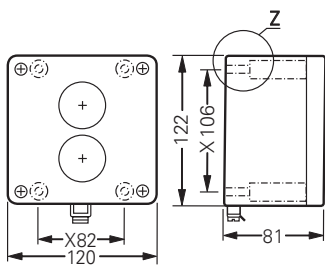

Type 413 84

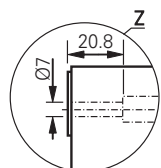
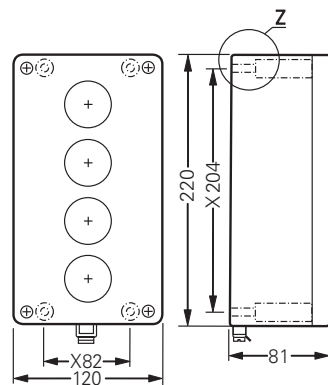

Type 413 85

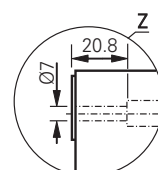
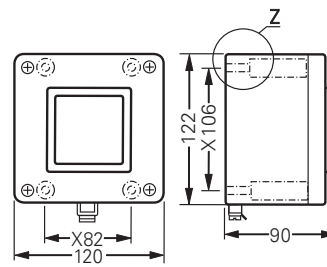

Type 413 84

X = fixing dimension

Dimensions in mm