

Technical Information

Liquiphant FTL31 IO-Link

Vibronic



Point level switch for liquids

Application

The Liquiphant FTL31 is a point level switch for liquids and is used in tanks, vessels and pipes.

It is used for overflow prevention or pump protection in cleaning and filter systems as well as in cooling and lubrication vessels, for instance.

Ideal for applications in which float switches or conductive, capacitance and optical sensors have been used up to now. The Liquiphant FTL31 also works in areas where these measuring principles are not suitable due to conductivity, buildup, turbulence, flow conditions or air bubbles.

The Liquiphant FTL31 can be used for process temperatures up to:

- 100 °C (212 °F)
- 150 °C (302 °F)

Not suitable for hazardous areas.

The use of the Liquiphant FTL33 is recommended for hygiene areas.

Your benefits









- Operational safety, reliability and universal application thanks to the tuning fork measuring principle
- Robust stainless steel housing (316L)
- External function test with test magnet
- Onsite function check possible thanks to LED indication
- Compact design for easy installation even in confined conditions or hard-to-access areas

Table of contents



| | | | |
|--|-----------|--|-----------|
| Important document information | 3 | Process | 14 |
| Symbols for certain types of information | 3 | Process temperature range | 14 |
| Symbols in graphics | 3 | Process pressure range | 14 |
| Function and system design | 4 | Density | 14 |
| Measuring principle | 4 | State of aggregation | 14 |
| Measuring system | 4 | Viscosity | 14 |
| Input | 5 | Solids contents | 14 |
| Measured variable | 5 | Lateral loading capacity | 14 |
| Measuring range | 5 | Mechanical construction | 15 |
| Output | 5 | Design | 15 |
| Switch output | 5 | Connector | 16 |
| Operating modes | 5 | Vibrating beam | 16 |
| Power supply | 5 | Sensor type | 17 |
| Supply voltage | 5 | Weight | 20 |
| Power consumption | 5 | Materials | 20 |
| Current consumption | 5 | Surface roughness | 21 |
| Electrical connection | 6 | Operability | 22 |
| Device plugs | 7 | LED indicator | 22 |
| Length of connecting cable | 7 | Function test with test magnet | 22 |
| Overvoltage protection | 7 | Certificates and approvals | 23 |
| Performance characteristics | 8 | CE mark | 23 |
| Reference operating conditions | 8 | EAC conformity | 23 |
| Switch point | 8 | RCM-Tick marking | 23 |
| Hysteresis | 8 | Approval | 23 |
| Non-repeatability | 8 | Marine approvals | 23 |
| Influence of ambient temperature | 8 | CRN approval | 23 |
| Influence of medium temperature | 8 | Inspection certificates | 23 |
| Influence of medium pressure | 8 | Manufacturer declarations | 23 |
| Switching delay | 8 | Pressure Equipment Directive | 23 |
| Switch-on delay | 8 | Other standards and guidelines | 23 |
| Measuring frequency | 8 | Ordering information | 24 |
| Measured error | 8 | Ordering information | 24 |
| Installation | 9 | Services (optional) | 24 |
| Orientation | 9 | Accessories | 24 |
| Installation instructions | 9 | Weld-in adapter | 24 |
| Length of connecting cable | 11 | Plug-in jack, cable | 24 |
| Environment | 12 | Additional accessories | 25 |
| Ambient temperature range | 12 | Supplementary documentation | 26 |
| Storage temperature | 12 | Operating Instructions | 26 |
| Climate class | 12 | Additional documentation | 26 |
| Altitude | 12 | Certificates | 26 |
| Degree of protection | 13 | | |
| Shock resistance | 13 | | |
| Vibration resistance | 13 | | |
| Electromagnetic compatibility | 13 | | |
| Reverse polarity protection | 13 | | |
| Short-circuit protection | 13 | | |

Important document information

Symbols for certain types of information

| Symbol | Meaning |
|---|--|
|  | Permitted Procedures, processes or actions that are permitted. |
|  | Preferred Procedures, processes or actions that are preferred. |
|  | Forbidden Procedures, processes or actions that are forbidden. |
|  | Tip Indicates additional information. |
|  | Reference to documentation. |
|  | Reference to page. |
|  | Reference to graphic. |
|  | Visual inspection. |

Symbols in graphics

| Symbol | Meaning |
|---|--|
| 1, 2, 3 ... | Item numbers |
| 1. 2. 3... | Series of steps |
| A, B, C, ... | Views |
| A-A, B-B, C-C, ... | Sections |
|  | Hazardous area Indicates the hazardous area. |
|  | Safe area (non-hazardous area) Indicates the non-hazardous area. |

Function and system design

Measuring principle

A piezoelectric drive causes the tuning fork of the device to vibrate at its resonance frequency. When the tuning fork is immersed in a liquid, its intrinsic frequency changes due to the change in density of the surrounding medium. The electronics system in the point level switch monitors the resonance frequency and indicates whether the tuning fork is vibrating in air or is covered by liquid.

Measuring system

The measuring system consists of a point level switch, e.g. for connection to programmable logic controllers (PLC).

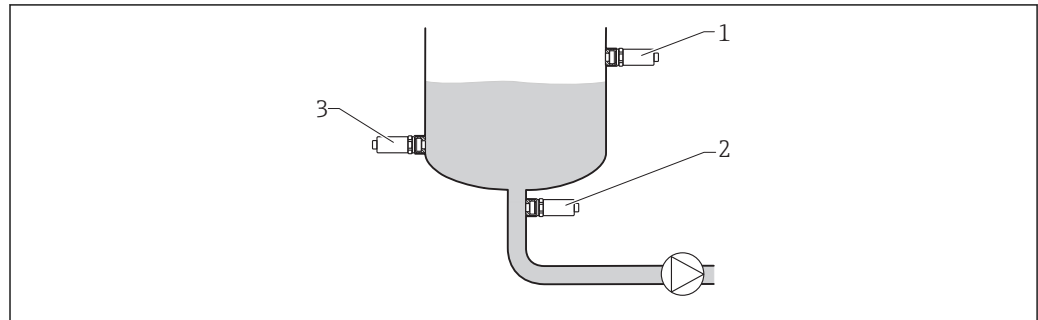

A0036961

1 Installation examples

- 1 Overfill prevention or upper level detection (maximum safety)
- 2 Dry running protection for pump (minimum safety)
- 3 Lower level detection (minimum safety)

Input

| | |
|--------------------------|-------------------|
| Measured variable | Density |
| Measuring range | customer-specific |

Output

| | |
|------------------------|---|
| Switch output | <p>Switching behavior: On/Off</p> <ul style="list-style-type: none"> ▪ Function 3-wire DC-PNP: Positive voltage signal at the switch output of the electronics (PNP), switching capacity 200 mA ▪ IO-Link (4-wire): Switching capacity:105 mA/200 mA |
| Operating modes | <p>The device has two operating modes: maximum safety (MAX) and minimum safety (MIN).</p> <p>By choosing the corresponding operating mode, the user ensures that the device also switches in a safety-oriented manner even in an alarm condition, e.g. if the power supply line is disconnected.</p> <ul style="list-style-type: none"> ▪ Maximum safety (MAX) The device keeps the electronic switch closed as long as the liquid level is below the fork. Sample application: overflow prevention ▪ Minimum safety (MIN) The device keeps the electronic switch closed as long as the fork is immersed in liquid. Sample application: Dry running protection for pumps <p>The electronic switch opens if the limit is reached, if a fault occurs or the power fails (quiescent current principle).</p> <p>Window functions</p> |

Power supply

| | |
|----------------------------|---|
| Supply voltage | <p>SIO mode 10 to 30 VDC</p> <p>IO-Link mode 18 to 30 VDC</p> <p>IO-Link communication is guaranteed only if the supply voltage is at least 18 V.</p> |
| Power consumption | < 1 W (at max. load: 200 mA) |
| Current consumption | < 15 mA |

Electrical connection

Connecting the device

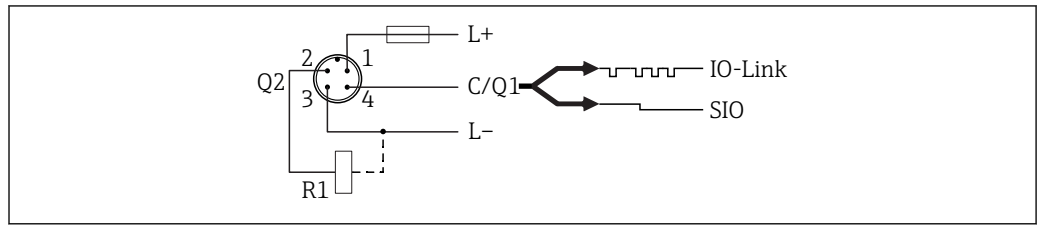

A0037916

- Pin 1 Supply voltage +
- Pin 2 1st switch output
- Pin 3 Supply voltage -
- Pin 4 IO-Link communication or 2nd switch output (SIO mode)

SIO mode (without IO-Link communication)















| Minimum safety | | |
|---------------------|------------|-------------------|
| Terminal assignment | MIN output | LED yellow (ye) 1 |
| | + 4 | |
| | + 4 | |

| Maximum safety | | |
|---------------------|------------|-------------------|
| Terminal assignment | MAX output | LED yellow (ye) 2 |
| | + 2 | |
| | + 2 | |

Function monitoring

When both outputs are connected, the MIN and MAX outputs assume opposite states (XOR) when the device is operating fault-free. In the event of an alarm condition or a cable break, both outputs are de-energized. This means that function monitoring is possible in addition to level monitoring. The behavior of the switch outputs can be configured via IO-Link.

| Connection for function monitoring using XOR operation | | | | | |
|--|------------|-------------------|------------|-------------------|--------------|
| Terminal assignment | MAX output | LED yellow (ye) 2 | MIN output | LED yellow (ye) 1 | Red LED (rd) |
| | + 2 | | + 4 | | |
| | + 2 | | + 4 | | |

| Connection for function monitoring using XOR operation | | | | | |
|--|---|---|---|---|---|
| Terminal assignment | MAX output | LED yellow (ye) 2 | MIN output | LED yellow (ye) 1 | Red LED (rd) |
| |  +  2 |  |  +  4 |  |  |
| |  +  2 |  |  +  4 |  |  |

Post-connection check

- Are the device and cable undamaged (visual inspection)?
- Does the supply voltage match the specifications on the nameplate?
- If supply voltage is present, is the green LED lit?
- With IO-Link communication: is the green LED flashing?

Device plugs M12 plug: IEC 60947-5-2

Length of connecting cable

- max. 25 Ω/core, total capacity < 100 nF
- IO-Link communication: < 10 nF

Overvoltage protection Overvoltage category II

Reverse polarity protection

Integrated; no damage in the event of reverse polarity or short-circuit

Short-circuit protection

Overload protection/short-circuit protection at I > 250 mA; the sensor is not destroyed.

If both switch outputs are active: 105 mA per switch output.

Intelligent monitoring:

Testing for overload at intervals of approx. 1.5 s; normal operation resumes once the overload/short-circuit has been rectified

Performance characteristics

| | | |
|---|---|---|
| Reference operating conditions | Ambient temperature: | +25 °C (+77 °F) |
| | Process pressure: | 1 bar (14.5 psi) |
| | Fluid: | Water (density: approx. 1 g/cm ³ , viscosity 1 mm ² /s) |
| | Medium temperature: | 25 °C (77 °F) |
| | Density setting: | > 0.7 g/cm ³ |
| | Switching time delay: | Standard (0.5 s, 1 s) |
| Switch point | 13 mm (0.51 in)±1 mm | |
| Hysteresis | max. 3 mm (0.12 in) | |
| Non-repeatability | ±1 mm (0.04 in) in accordance with DIN 61298-2 | |
| Influence of ambient temperature | Negligible | |
| Influence of medium temperature | -25 µm (984 µin)/°C | |
| Influence of medium pressure | -20 µm (787 µin)/bar | |
| Switching delay | <ul style="list-style-type: none"> ■ 0.5 s when tuning fork is covered ■ 1.0 s when tuning fork is uncovered ■ Optionally available: 0.2 s; 1.5 s or 5 s (when the tuning fork is covered and uncovered) ■ Can be configured via IO-Link from 0.3 to 60 s | |
| Switch-on delay | max. 3 s | |
| Measuring frequency | Approx. 1 100 Hz in air | |
| Measured error | In event of device change: ±2 mm (0.08 in) as per DIN 61298-2 | |

Installation

Orientation

The point level switch can be installed in any position in a vessel, pipe or tank. Foam formation does not affect the function.

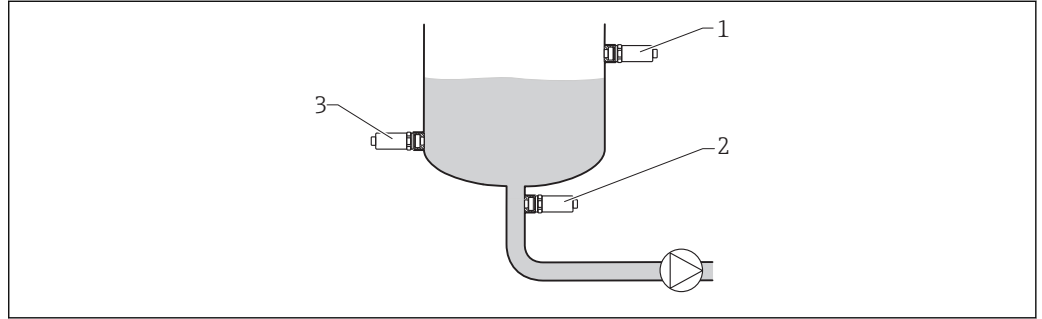

A0036961

2 Installation examples

- 1 Overfill prevention or upper level detection (maximum safety)
- 2 Dry running protection for pump (minimum safety)
- 3 Lower level detection (minimum safety)

Installation instructions

Switch point

The switch point (A) on the sensor depends on the orientation of the point level switch (water +25 °C (+77 °F), 1 bar (14.5 psi)).

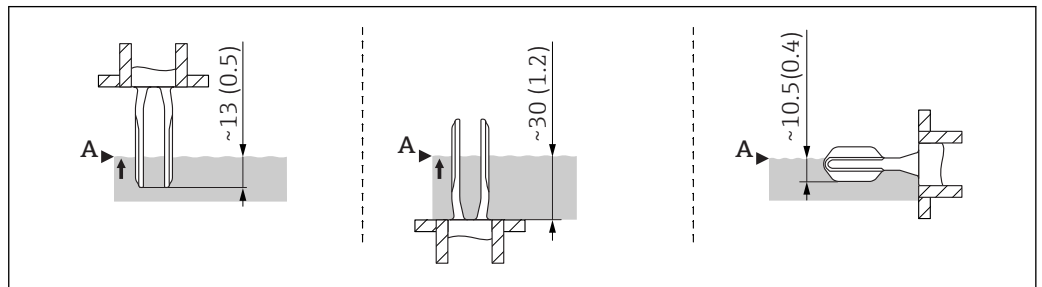

A0020734

3 Vertical and horizontal orientation, dimensions in mm (in)

Short tube version

The use of the short tube ensures that the switch point is at the same level as in the previous Liquiphant FTL260 model when an identical thread is selected. In this way, the device can be replaced quickly and easily. (Applies for process connections G 1" weld-in adapter for flush-mounted installation, MNPT 1" and R 1")

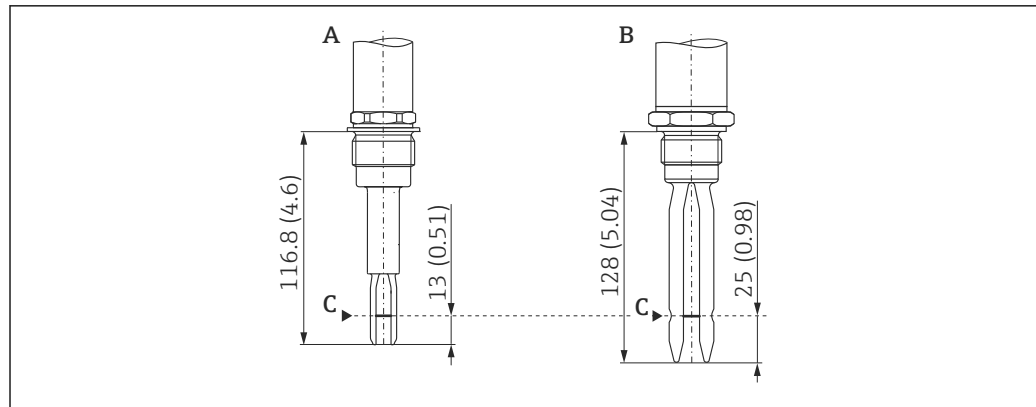

A0022122

Dimensions mm (in)

- A Liquiphant FTL31 with short tube
- B Liquiphant FTL260
- C Switch point

Installation in pipes

During installation, pay attention to the position of the fork in order to minimize turbulence in the pipe.

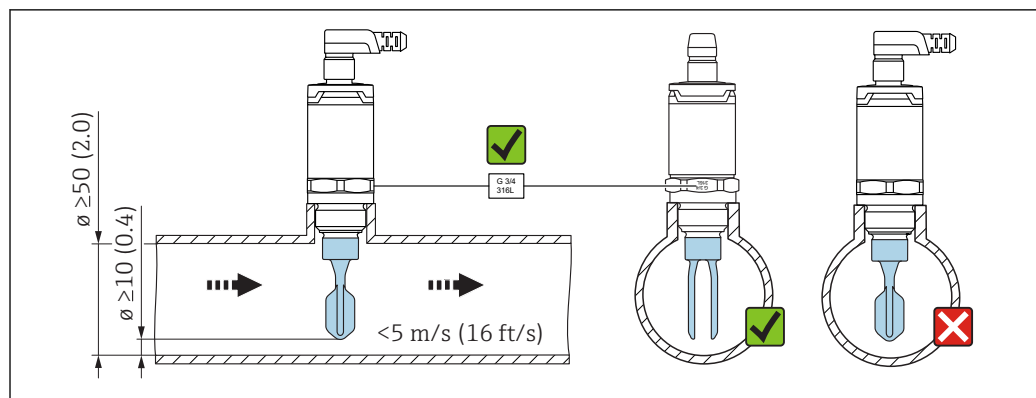

A0021357

Dimensions mm (in)

Installation in vessels

If installed horizontally, pay attention to the position of the tuning fork to ensure that the liquid can drip off.

The electrical connection, e.g. M12 connector, should be pointing down with the cable. This can prevent moisture from penetrating.

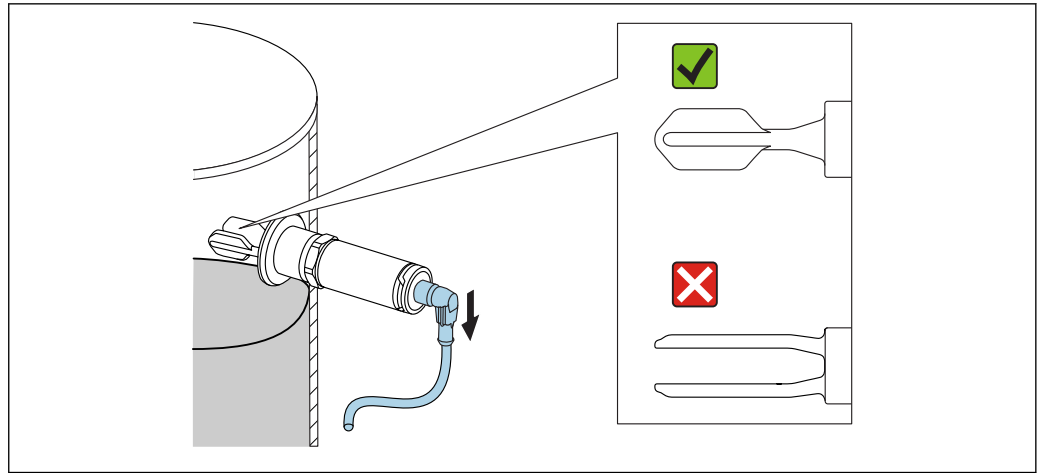

A0021034

4 Position of the fork in the case of horizontal installation in a vessel

Distance from wall

Ensure that there is sufficient distance between the expected buildup on the tank wall and the fork. Recommended distance from wall ≥ 10 mm (0.39 in).

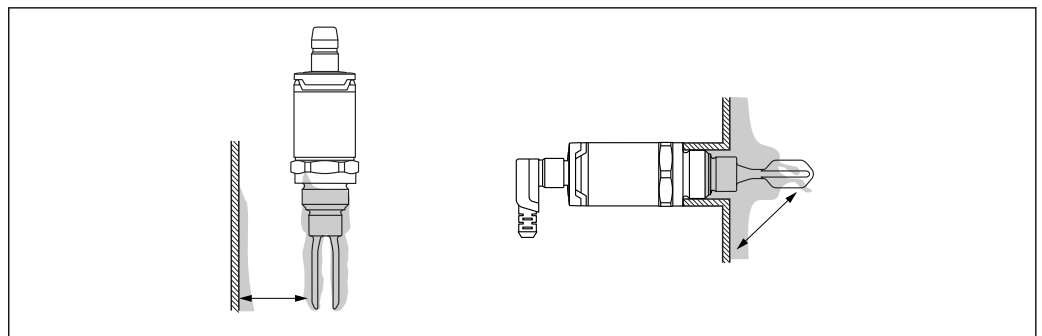

A0022272

Length of connecting cable

- to 1000 m (3 281 ft)
- max. 25 Ω /wire, total capacitance < 100 nF

Environment

Ambient temperature range -40 to +70 °C (-40 to +158 °F)

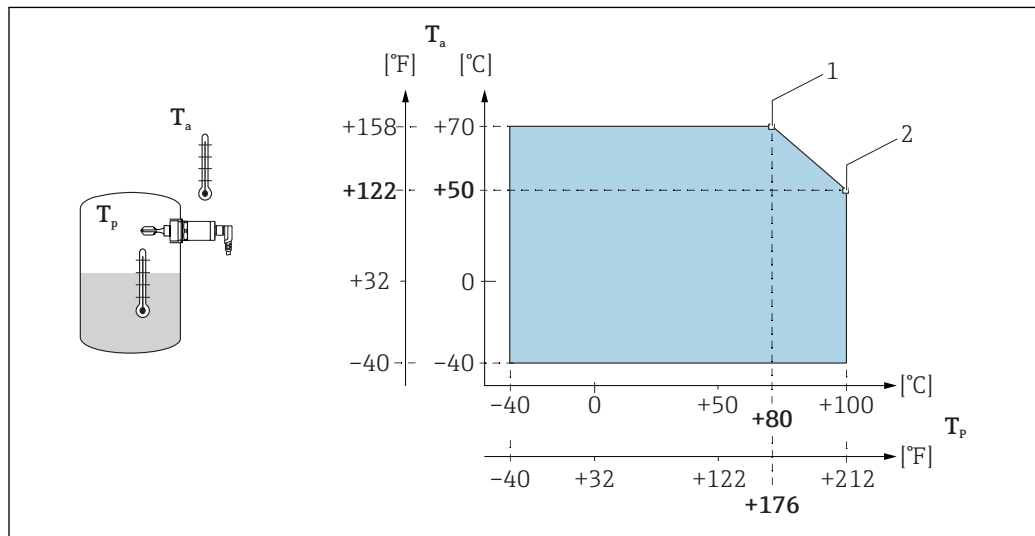

A0022002

5 Derating curve: 100 °C (212 °F)

1 I_{max} : 200 mA (DC-PNP), 250 mA (AC/DC)

2 I_{max} : 150 mA (DC-PNP), 150 mA (AC/DC)

T_a Ambient temperature range

T_p Process temperature

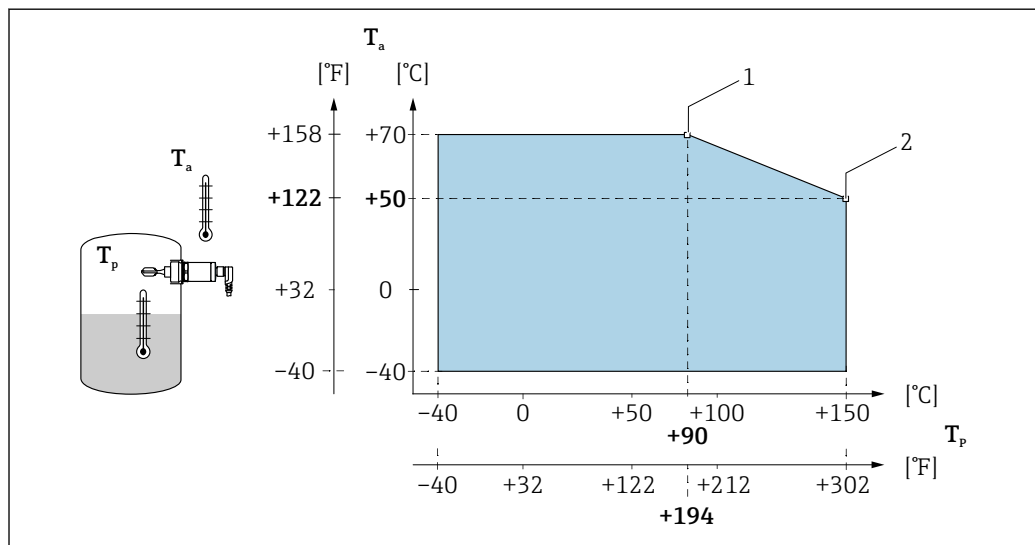

A0020869

6 Derating curve: 150 °C (302 °F)

1 I_{max} : 200 mA (DC-PNP), 250 mA (AC/DC)

2 I_{max} : 150 mA (DC-PNP), 150 mA (AC/DC)

T_a Ambient temperature range

T_p Process temperature

Storage temperature -40 to +85 °C (-40 to +185 °F)

Climate class DIN EN 60068-2-38/IEC 68-2-38: Test Z/AD

Altitude Up to 2 000 m (6 600 ft) above sea level

| | |
|--------------------------------------|--|
| Degree of protection | <ul style="list-style-type: none">▪ IP65/67 NEMA Type 4X Enclosure (M12 connector)▪ IP65 NEMA Type 4X Enclosure (valve plug)▪ IP66/68 NEMA Type 4X/6P Enclosure (cable) |
| Shock resistance | a = 300 m/s ² = 30 g, 3 planes x 2 directions x 3 shocks x 18 ms, as per test Ea, prEN 60068-2-27:2007 |
| Vibration resistance | a(RMS) = 50 m/s ² , ASD = 1.25 (m/s ²) ² /Hz, f = 5 to 2000 Hz, t = 3 x 2 h, as per test Fh, EN 60068-2-64:2008 |
| Electromagnetic compatibility | Electromagnetic compatibility in accordance with all relevant requirements of the EN 61326 series and NAMUR recommendation EMC (NE21). For details, refer to the EC Declaration of Conformity. The EC Declaration of Conformity is available in the Download Area of the Endress+Hauser website: www.endress.com → Downloads. |
| Reverse polarity protection | 3-wire DC-PNP and IO-Link Integrated. In the event of reverse polarity, the device is deactivated automatically. |
| Short-circuit protection | 3-wire DC-PNP and IO-Link <ul style="list-style-type: none">▪ Overload protection/short-circuit protection at I > 250 mA; the sensor is not destroyed.▪ If both switch outputs are active: 105 mA per switch output. Intelligent monitoring: Testing for overload at intervals of approx. 1.5 s; normal operation resumes once the overload/short-circuit has been rectified. |

Process



Note the pressure and temperature derating depending on the process connection selected.

| | |
|----------------------------------|--|
| Process temperature range | -40 to +100 °C (-40 to +212 °F) -40 to +150 °C (-40 to +302 °F) |
| Process pressure range | Max. -1 to +40 bar (-14.5 to +580 psi) |
| Density | Can be configured via IO-Link |
| State of aggregation | Liquid |
| Viscosity | 1 to 10 000 mPa·s, dynamic viscosity |
| Solids contents | $\varnothing < 5$ mm (0.2 in) |
| Lateral loading capacity | Lateral loading capacity of the tuning fork: maximum 200 N |

Mechanical construction

Design

The point level switch is available in different versions and can be assembled in accordance with user specifications.

The versions can be selected via the product structure in the Product Configurator, see the "Ordering information" section. For examples, see below:

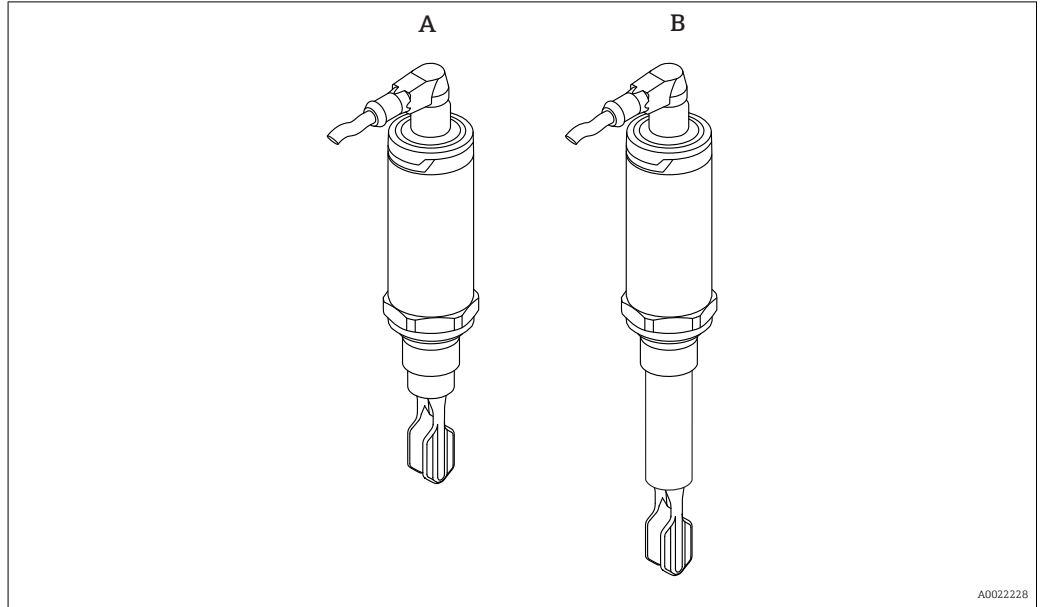

| Versions | Examples | |
|---|-----------------|--------------------|
| | A | B |
| Electrical connection | M12 plug | M12 plug |
| Housing (sensor design) for process temperatures up to: | 150 °C (302 °F) | 150 °C (302 °F) |
| Sensor type | Compact version | Short tube version |



For detailed information on the process connections, see the "Sensor type" section.



For information on the short tube version, see the "Installation instructions" section.

Connector

Dimensions

Dimensions mm (in)

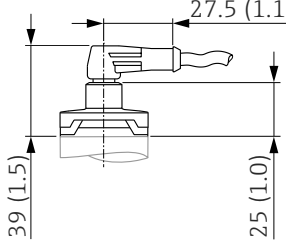
| Electrical connection with housing cover | Designation |
|--|---|
|  <p style="text-align: right; font-size: small;">A0021857</p> | <p>M12 plug for housing cover: PPSU plastic (IP65/67)</p> |

Vibrating beam

Dimensions

Dimensions mm (in)

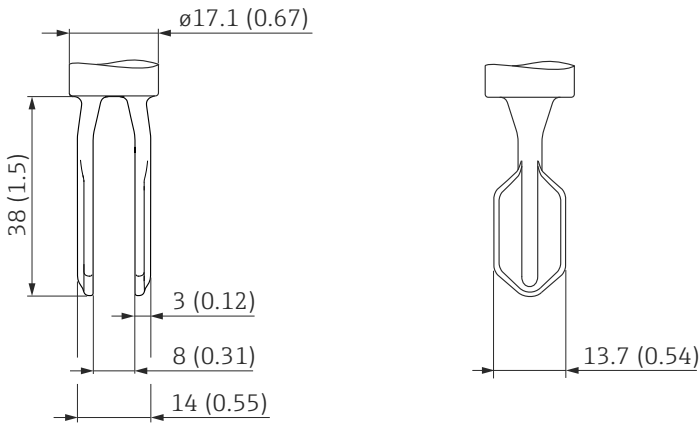
| |
|--|
|  <p style="text-align: right; font-size: small;">A0022250</p> |
|--|

Sensor type

Dimensions

Dimensions mm (in)

The total dimensions of the device can vary depending on the connector selected. To determine the total dimensions, please refer also to the "Electrical connection" section .

Information on the following tables

- Meaning of symbols:
 - * Dimension for process temperature max. 100 °C (212 °F)
 - ** Dimension for process temperature max. 150 °C (302 °F)
- If several versions have the same dimensions, one example of the compact version and one example of the short tube version is given.
- The versions in the second column refer to the process connections in the product structure.

 For information on weld-in adapters, see "Technical Documentation" for weld-in adapters, process adapters and flanges

Available in Downloads area of the Endress+Hauser website (www.endress.com/downloads).

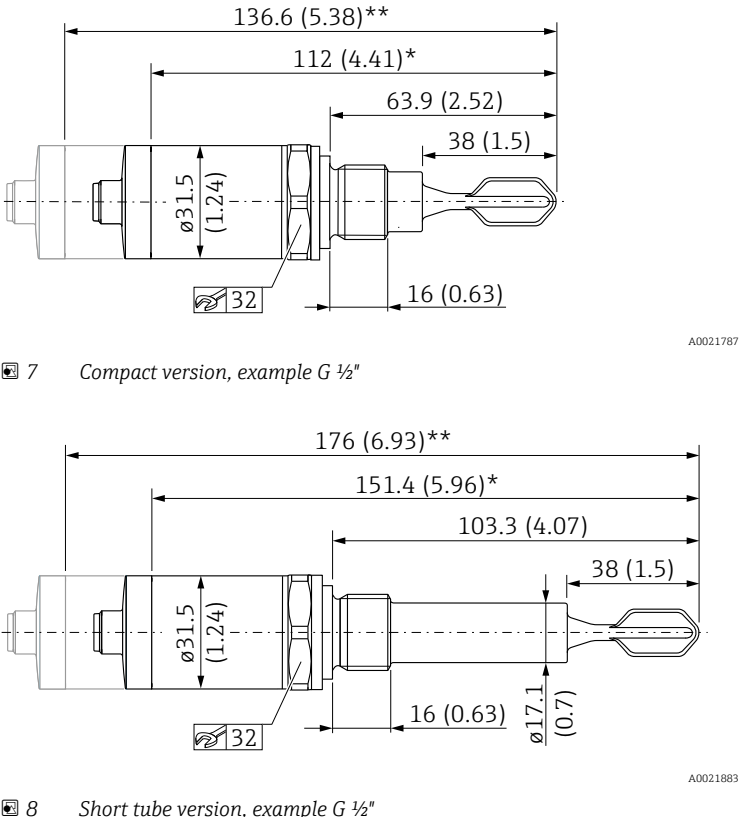
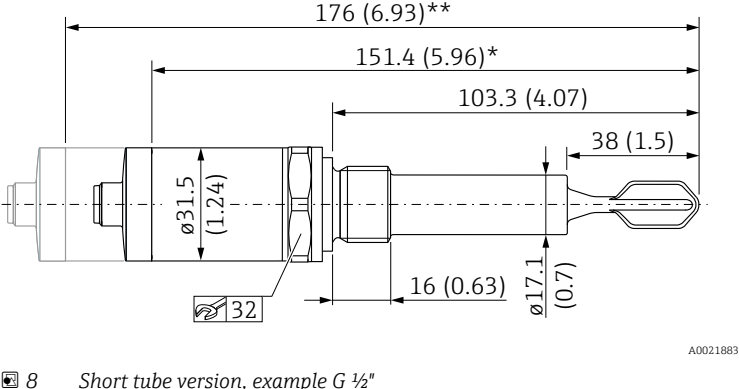
| Dimensions | Version | Description |
|--|--------------------|---|
|  <p>7 Compact version, example G 1/2"</p> <p style="text-align: right;"><small>A0021787</small></p> | <p>WBJ WCJ</p> | <p>Thread ISO 228 G 1/2" Thread ISO 228 G 3/4"</p> <ul style="list-style-type: none"> ■ Material: 316L ■ Scope of delivery: flat seal (FA) ■ Pressure and temperature (maximum): +40 bar (+580 psi) at +150 °C (+302 °F) <p>W5J</p> <p>Thread ISO 228 G 3/4" for flush-mounted installation in weld-in adapter</p> <ul style="list-style-type: none"> ■ Material: 316L ■ Scope of delivery: flat seal (FA) <p>Accessory: weld-in adapter</p> <ul style="list-style-type: none"> - Scope of delivery: seal (VMQ) - Pressure and temperature (maximum): +25 bar (+352 psi) at +150 °C (+302 °F) +40 bar (+580 psi) at +100 °C (+212 °F) <p>The dimensions apply for G 1/2"; G 3/4" and G 3/4" for flush-mounted installation.</p> |
|  <p>8 Short tube version, example G 1/2"</p> <p style="text-align: right;"><small>A0021883</small></p> | | |

| Dimensions | Version | Description |
|---|------------|--|
| <p>9 Compact version</p> <p>10 Short tube version</p> | <p>WDJ</p> | <p>Thread ISO 228 G 1"</p> <ul style="list-style-type: none"> Material: 316L Scope of delivery: flat seal (FA) Pressure and temperature (maximum): +40 bar (+580 psi) at +150 °C (+302 °F) |

| Dimensions | Version | Description |
|--|------------|--|
| <p>11 Compact version</p> <p>12 Short tube version</p> | <p>WSJ</p> | <p>Thread ISO 228 G 1" for flush-mounted installation in weld-in adapter</p> <ul style="list-style-type: none"> Material: 316L Scope of delivery: flat seal (FA) <p>Accessory: weld-in adapter</p> <ul style="list-style-type: none"> Scope of delivery: seal (VMQ) Pressure and temperature (maximum): +25 bar (+362 psi) at +150 °C (+302 °F) +40 bar (+580 psi) at +100 °C (+212 °F) |

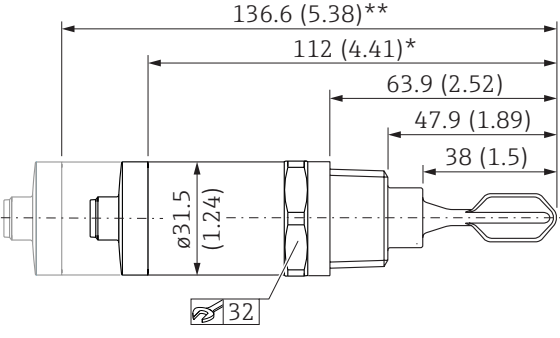
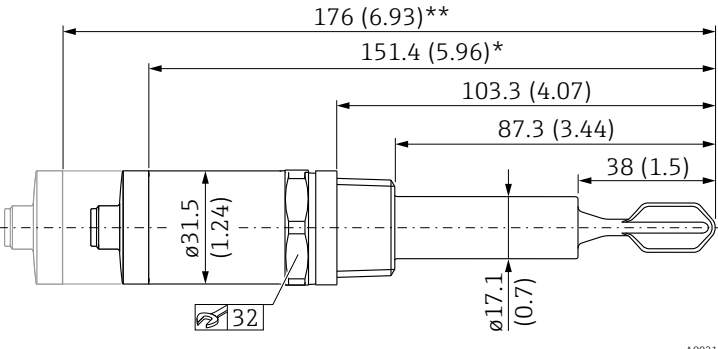
| Dimensions | Version | Description |
|---|---|---|
|  <p data-bbox="164 616 566 649">13 Compact version, example MNPT 3/4"</p>  <p data-bbox="164 1041 582 1075">14 Short tube version, example MNPT 3/4"</p> | <p data-bbox="938 257 981 280">VAJ</p> <p data-bbox="938 302 981 324">VBJ</p> <p data-bbox="938 347 981 369">XBJ</p> <p data-bbox="938 392 981 414">XCJ</p> | <p data-bbox="1018 257 1252 280">Thread ASME MNPT 1/2"</p> <p data-bbox="1018 302 1252 324">Thread ASME MNPT 3/4"</p> <p data-bbox="1018 347 1236 369">Thread EN10226 R 1/2"</p> <p data-bbox="1018 392 1236 414">Thread EN10226 R 3/4"</p> <p data-bbox="1018 436 1380 481">Pressure and temperature (maximum): +40 bar (+580 psi) at +150 °C (+302 °F)</p> <p data-bbox="1018 504 1492 548">The dimensions apply for MNPT 1/2", MNPT 3/4"; R 1/2" and R 3/4".</p> |

| Dimensions | Version | Description |
|---|---------|--|
| <p>15 Compact version, example MNPT 1"</p> | VCJ | Thread ASME MNPT 1" |
| | XDJ | Thread EN10226 R 1" Pressure and temperature (maximum): +40 bar (+580 psi) at +150 °C (+302 °F) The dimensions apply for MNPT 1" and R 1". |
| <p>16 Short tube version, example MNPT 1"</p> | | |

i Endress+Hauser supplies DIN/EN process connections with threaded connection in stainless steel in accordance with AISI 316L (DIN/EN material number 1.4404 or 1.4435). In terms of their stability-temperature property, the materials 1.4404 and 1.4435 are grouped in EN 1092-1 table 18 under 13EO. The chemical composition of the two materials can be identical.

| Weight | Sensor type | Weight |
|--------|---|--------------------------|
| | Compact version with process adapter G ½" and valve plug for process temperature up to 100 °C (212 °F) | Approx. 140 g (4.938 oz) |
| | Short tube version with process adapter G ½" and valve plug for process temperature up to 150 °C (302 °F) | Approx. 169 g (5.961 oz) |

Materials

Material specifications in accordance with AISI and DIN EN.

Materials in contact with process

| Component part | Material |
|--|--|
| Vibrating beam | 316L |
| Process adapter | 316L (1.4404/1.4435) |
| Short tube | 316L (1.4404/1.4435) |
| Seal for weld-in adapter with G ¾", G 1" | VMQ |
| Flat seal | FA (composite material based on aramid fibers combined with NBR) |

Materials not in contact with process

| Component part | Material |
|--|------------------------------------|
| Housing cover with M12 connector (IP65/67) | PPSU |
| Housing cover with valve plug (IP65) | |
| Housing cover with cable (IP66/68) | |
| Cable gland | PVDF |
| Design ring | PBT/PC |
| Housing | 316L (1.4404/1.4435) |
| Nameplate | Plastic foil (attached to housing) |

Surface roughness

Metallic surface in contact with process:

Ra ≤ 3.2 μm (126 μin)



The surface is not defined in the area of the welding seam.

Operability

LED indicator

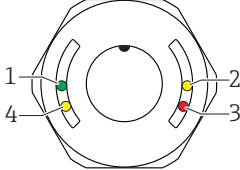

A0036944

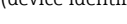
| Position | LED color | Description of function |
|----------|--------------|--|
| 1 | green (gn) | Status/communication <ul style="list-style-type: none"> ▪ lit: SIO mode ▪ flashing: Active communication, flash frequency  ▪ flashes with increased luminosity: Device search (device identification), flash frequency  |
| 2 | yellow (ye)1 | Switch status/switch output 1 With IO-Link communication in accordance with customer calibration: sensor is covered by medium . |
| 3 | red (rd) | Warning/Maintenance required flashing: Error remediable, e. g. invalid calibration Fault/device failure lit: see Diagnostics and troubleshooting |
| 4 | yellow (ye)2 | Switch status/switch output 2 ¹⁾ With IO-Link communication in accordance with customer calibration: sensor is covered by medium . |

1) Activated only if both switch outputs are active.

Function test with test magnet

Carry out a function test while the device is in operation.

- ▶ Hold the test magnet against the marking on the housing for at least 2 seconds.
 - ↳ This inverts the current switch status, and the yellow LED changes state. When the magnet is removed, the switching status valid at that time is adopted.

If the test magnet is held against the marking for longer than 30 seconds, the red LED will flash: The device returns automatically to the current switch status.

 The test magnet is not included in the scope of delivery. It can be ordered as an optional accessory .

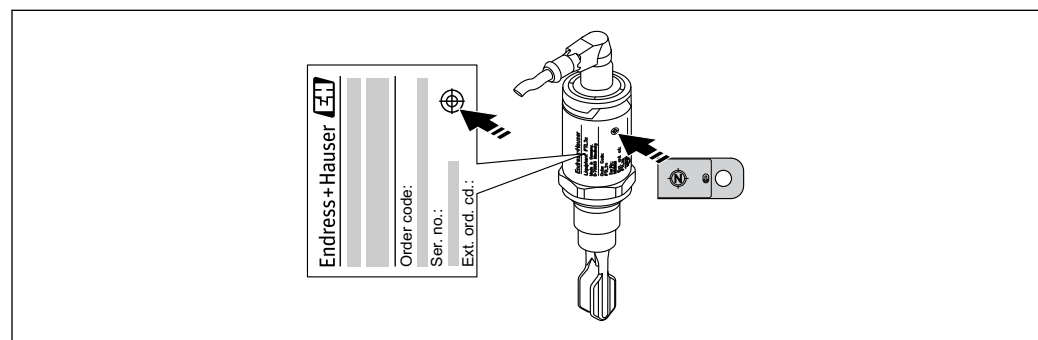

 17 Position for test magnet on housing

Certificates and approvals



The following documents are also available in the Download Area of the Endress+Hauser website: www.endress.com → Downloads.

| | |
|---------------------------------------|---|
| CE mark | The measuring system is in conformity with the statutory requirements of the applicable EC Directives. These are listed in the corresponding EC Declaration of Conformity along with the standards applied. Endress+Hauser confirms successful testing of the device by affixing to it the CE mark. |
| EAC conformity | The measuring system meets the legal requirements of the applicable EAC guidelines. These are listed in the corresponding EAC Declaration of Conformity together with the standards applied. Endress+Hauser confirms successful testing of the device by affixing to it the EAC mark. |
| RCM-Tick marking | The supplied product or measuring system meets the ACMA (Australian Communications and Media Authority) requirements for network integrity, interoperability, performance characteristics as well as health and safety regulations. Here, especially the regulatory arrangements for electromagnetic compatibility are met. The products are labelled with the RCM- Tick marking on the name plate. <div style="text-align: center;"></div> <small>A0029561</small> |
| Approval | CSA C/US General Purpose |
| Marine approvals | <ul style="list-style-type: none"> ▪ GL (German Lloyd) ▪ ABS (American Bureau of Shipping) ▪ LR (Lloyds Register) ▪ BV (Bureau Veritas) ▪ DNV (Det Norske Veritas) |
| CRN approval | Versions with a CRN approval (Canadian Registration Number) are listed in the corresponding registration documents. CRN-approved devices are labeled with registration number OF16950.5C on the nameplate. You can find further details on the maximum pressure values in the Download Area of the Endress+Hauser website. |
| Inspection certificates | The following documents can be ordered with the device (optional): <ul style="list-style-type: none"> ▪ Acceptance test certificate as per EN 10204-3.1 ▪ Final inspection report |
| Manufacturer declarations | The following manufacturer declarations can be ordered (optional): <ul style="list-style-type: none"> ▪ FDA conformity ▪ TSE-free, materials free from animal origin ▪ ROHS-compliant in accordance with Endress+Hauser regulation |
| Pressure Equipment Directive | The device does not fall within the scope of Pressure Equipment Directive 97/23/EC as it does not have a pressurized housing as defined in Article 1, Section 2.1.4 of the directive. |
| Other standards and guidelines | The applicable European guidelines and standards can be found in the relevant EU Declarations of Conformity. |

Ordering information

Ordering information

Detailed ordering information is available from the following sources:

- In the Product Configurator on the Endress+Hauser website: www.endress.com -> Click "Corporate" -> Select your country -> Click "Products" -> Select the product using the filters and search field -> Open product page -> The "Configure" button to the right of the product image opens the Product Configurator.
- From your Endress+Hauser Sales Center: www.addresses.endress.com

Product Configurator - the tool for individual product configuration

- Up-to-the-minute configuration data
- Depending on the device: Direct input of measuring point-specific information such as measuring range or operating language
- Automatic verification of exclusion criteria
- Automatic creation of the order code and its breakdown in PDF or Excel output format
- Ability to order directly in the Endress+Hauser Online Shop

Services (optional)

In addition, the following services can be selected via the product structure in the Product Configurator:

- Cleaned of oil+grease
- PWIS-free (PWIS = paint-wetting impairment substances)
- Density setting > 0.5 g/cm³
- Switching delay setting

Accessories

Weld-in adapter

Various weld-in adapters are available for installation in vessels or pipes.

-  The adapters are optionally available with inspection certificate 3.1 EN10204.

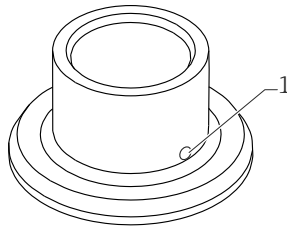
| View (example) | Description |
|---|---|
|  <p>1 Leakage hole</p> | G 3/4" ø29 pipe installation ø50 vessel installation FDA-listed materials as per 21 CFR Part 175-178 |
| | G 1" ø53 pipe installation ø60 vessel installation |

If installed horizontally and weld-in adapters with a leakage hole are used, ensure that the leakage hole is pointing down. This allows leaks to be detected as quickly as possible.

-  For detailed information on accessories, see "Technical Information".

Available in Downloads area of the Endress+Hauser website (www.endress.com/downloads).

Plug-in jack, cable

-  The plug-in jacks listed are suitable for use in the temperature range -25 to +70 °C (-13 to +158 °F).

Engineering unit mm (in)

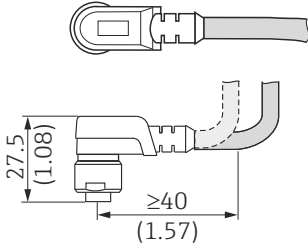
| Plug-in jack M12 IP67 | Description | Order number |
|---|---|--------------|
|  <p>A0022292</p> | <ul style="list-style-type: none"> ▪ Elbowed 90° ▪ 5 m (16 ft) PVC cable (gray) ▪ Slotted nut Cu Sn/Ni ▪ Body: PUR (blue) | 52010285 |

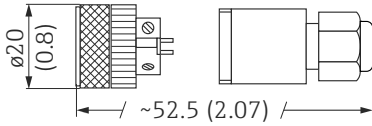
| Plug-in jack M12 IP67 | Description | Order number |
|---|--|--------------|
|  <p>A0022293</p> | <ul style="list-style-type: none"> ▪ Self-terminated connection to M12 connector ▪ Slotted nut Cu Sn/Ni ▪ Body: PBT | 52006263 |

Wire colors for M12 connector: 1 = BN (brown), 2 = WT (white), 3 = BU (blue), 4 = BK (black)

Additional accessories

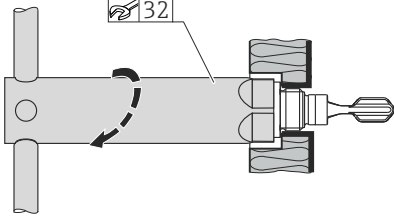
| Socket wrench for mounting | Description | Order number |
|---|---|--------------|
|  <p>A0022273</p> | <ul style="list-style-type: none"> ▪ Hexagonal ▪ Size across flats AF32 | 52010156 |

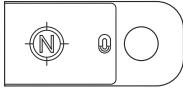
| Test magnet | Description | Order number |
|---|------------------------------------|--------------|
|  <p>A0021732</p> | Information in "Operation" section | 71267011 |

Supplementary documentation



The following document types are available in the Download Area of the Endress+Hauser website: www.endress.com → Downloads.

Operating Instructions

Liquiphant FTL31 IO-Link → BA01935F/00

Additional documentation

TI00426F/00 → Weld-in adapters, process adapters and flanges (overview)

SD01622Z/00 → Weld-in adapter (installation instructions)

SD00356F/00 → Valve plug (installation instructions)

Certificates

ZE01010F/00 → Overfill protection

ZE01011F/00 → Leaks



71417207

www.addresses.endress.com
