

August 2016

67C Series Instrument Supply Regulators

- Designed for Digital Instrumentation
- Optional Smart Bleed™ Construction
- Optional Stainless Steel Construction
- Compact and Light Weight
- No Air Loss
- Easy Maintenance
- Optional Integral Filter
- Optional Internal Relief Valve
- Rugged Construction

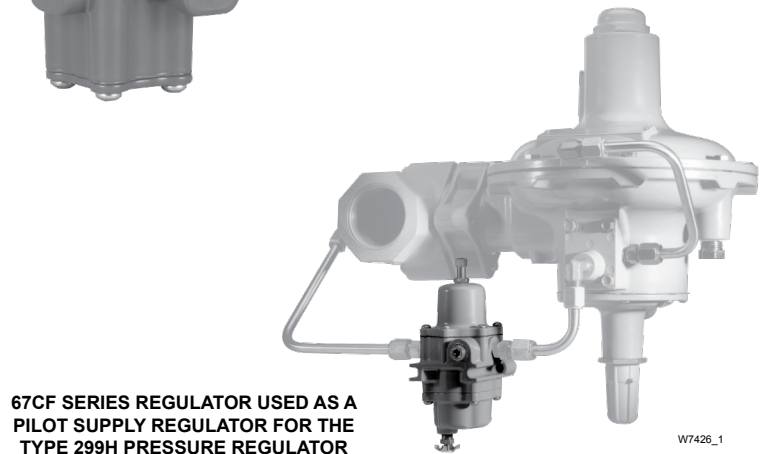
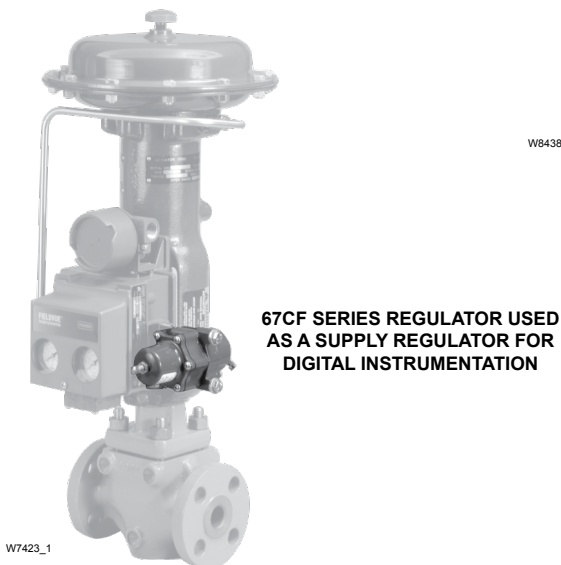

Figure 1. 67C Series Instrument Supply Regulators

Bulletin 71.1:67C

Specifications

The Specifications section gives some general specifications for the 67C Series regulator. A label on the spring case gives the control spring range for a given regulator as it comes from the factory.

Available Constructions

See Table 2

Body Size, Inlet and Outlet Connection Style

1/4 NPT

Construction Materials

See Table 3

Maximum Inlet Pressure (Body Rating)⁽¹⁾

All except Types 67CS and 67CSR: 250 psig / 17.2 bar

Types 67CS and 67CSR: 400 psig / 27.6 bar

Outlet Pressure Ranges

See Table 1

Maximum Emergency Outlet Pressure⁽¹⁾

50 psi / 3.4 bar over outlet pressure setting

Flow Capacities

See Table 4

Wide-Open Flow Coefficients

Main Valve: C_g : 11.7; C_v : 0.36; C_f : 32.2

Internal Relief Valve: C_g : 1.45; C_v : 0.045; C_f : 32.8

IEC Sizing Coefficients

Main Valve: X_T : 0.66; F_L : 0.89; F_D : 0.50

Accuracy

Inlet Sensitivity for Nitrile (NBR) and

Silicone (VMQ) Elastomers: Less than 0.2 psig / 14 mbar change in outlet pressure for every 25 psig / 1.7 bar change in inlet pressure

Inlet Sensitivity for Fluorocarbon (FKM) Elastomers:

Less than 0.4 psig / 28 mbar change in outlet pressure for every 25 psig / 1.7 bar change in inlet pressure

Repeatability for Nitrile (NBR) and Silicone (VMQ)

Elastomers: 0.1 psig / 7 mbar⁽²⁾

Repeatability for Fluorocarbon (FKM) Elastomers:

0.3 psig / 21 mbar⁽²⁾

Air Consumption: Testing repeatedly shows no discernible leakage

Types 67CR, 67CSR, 67CFR and 67CFSR Internal Relief Performance

Low capacity for minor seat leakage only, other overpressure protection must be provided if inlet pressure can exceed the maximum pressure rating of downstream equipment or exceeds maximum outlet pressure rating of the regulator.

Approximate Weights

Types 67C, 67CR, 67CF and 67CFR:

1 lb / 0.5 kg

Types 67CS and 67CSR:

2.5 lbs / 1.1 kg

Types 67CFS and 67CFSR:

4 lbs / 1.8 kg

Smart Bleed™ Check Valve Setpoint

6 psi / 0.41 bar differential

Pressure Registration

Internal

Drain Valve and Spring Case Vent Location

Aligned with inlet standard, other positions optional

Temperature Capabilities⁽¹⁾

With Nitrile (NBR)

Standard Bolting: -20 to 180°F / -29 to 82°C

Stainless Steel Bolting: -40 to 180°F / -40 to 82°C

With Fluorocarbon (FKM):

Polyethylene Filter⁽⁵⁾ (Standard): 0 to 180°F / -18 to 82°C

Polyvinylidene (PVDF), Stainless Steel or

Glass Filter (Optional): 0 to 300°F / -18 to 149°C

With Silicone (VMQ)⁽³⁾ Diaphragm and Low

Temperature bolting: -60 to 180°F / -51 to 82°C

With Gauges: -40 to 180°F / -40 to 82°C

Types 67CF, 67CFR, 67CFS and 67CFSR

Filter Capabilities

Free Area: 12 times pipe area

Micron Rating:

Polyethylene Filter⁽⁵⁾ (Standard): 5 microns

Glass Fiber Filter (Optional): 5 microns

PVDF Filter (Optional): 40 microns

Stainless Steel Filter (Optional): 40 microns

Options

All Types

- Handwheel adjusting screw
- Inlet screen
- NACE MR0175⁽⁴⁾ or NACE MR0103 construction
- Panel mount (includes spring case with 1/4 NPT vent, handwheel and panel mounting nut)
- Closing cap (available on spring case with 1/4 NPT vent)
- Fluorocarbon (FKM) elastomers for high temperatures and/or corrosive chemicals
- Silicone (VMQ) elastomers for cold temperatures
- Fixed Bleed Restriction
- Triple scale outlet pressure gauge (Brass or Stainless steel)
- Stainless steel stem on the valve plug
- Tire valve or pipe plug in second outlet

Types 67CFR and 67CFSR only

- Smart Bleed internal check valve
- Large dripwell with manual or automatic drain

Types 67CF and 67CFR only

- Stainless steel drain valve

1. The pressure/temperature limits in this Bulletin and any applicable standard or code limitation should not be exceeded.

2. Repeatability is the measure of the regulator's ability to return to setpoint consistently when traveling from steady state to transient to steady state.

3. Silicone (VMQ) is not compatible with hydrocarbon gas.

4. Product complies with the material requirements of NACE MR0175. Environmental limits may apply.

5. Do not use in high aromatic hydrocarbon service.

Table 1. Outlet Pressure Ranges and Control Spring Data

| TYPE | OUTLET PRESSURE RANGE | | CONTROL SPRING DATA | | | | | | |
|----------------------------------|-----------------------|-----------|---------------------|------------|-------------|---------------|------|-------------|------|
| | | | Color | Material | Part Number | Wire Diameter | | Free Length | |
| | psig | bar | | | | In. | mm | In. | mm |
| 67C, 67CR, 67CF and 67CFR | 0 to 20 | 0 to 1.4 | Green stripe | Music Wire | GE07809T012 | 0.135 | 3.43 | 1.43 | 36.2 |
| | 0 to 35 | 0 to 2.4 | Silver | | T14059T0012 | 0.156 | 3.96 | 1.43 | 36.2 |
| | 0 to 60 | 0 to 4.1 | Blue stripe | | T14058T0012 | 0.170 | 4.32 | 1.43 | 36.2 |
| | 0 to 125 | 0 to 8.6 | Red stripe | | T14060T0012 | 0.207 | 5.26 | 1.43 | 36.2 |
| | 0 to 35 | 0 to 2.4 | Silver stripe | Inconel® | T14113T0012 | 0.156 | 3.96 | 1.43 | 36.2 |
| | 0 to 60 | 0 to 4.1 | Blue | | T14114T0012 | 0.172 | 4.37 | 1.43 | 36.2 |
| 0 to 125 | 0 to 8.6 | Red | T14115T0012 | | 0.207 | 5.26 | 1.43 | 36.2 | |
| 67CS, 67CSR, 67CFS and 67CFSR | 0 to 20 | 0 to 1.3 | Green | Inconel® | 10C1729X012 | 0.135 | 3.43 | 1.50 | 38.1 |
| | 0 to 35 | 0 to 2.4 | Silver stripe | | T14113T0012 | 0.156 | 3.96 | 1.43 | 36.2 |
| | 0 to 60 | 0 to 4.1 | Blue | | T14114T0012 | 0.172 | 4.37 | 1.43 | 36.2 |
| | 0 to 125 | 0 to 8.6 | Red | | T14115T0012 | 0.207 | 5.26 | 1.43 | 36.2 |
| | 0 to 150 | 0 to 10.3 | Black | | 10C1730X012 | 0.250 | 6.35 | 1.77 | 44.9 |

Introduction

The 67C Series regulators are typically used to provide constantly controlled, reduced pressures to pneumatic and electro-pneumatic controllers and other instruments. These direct-operated regulators are suitable for most air or gas applications. Other applications include providing reduced pressures to air chucks, air jets and spray guns.

Features

- **Compact**—The 67C Series regulators are engineered for outstanding performance in a compact, lightweight package.
- **Panel Mounting**—Panel mount construction includes spring case with 1/4 NPT vent, handwheel adjusting screw and mounting nut.
- **Instrument Supply Regulator**—The Types 67CF, 67CFR, 67CFS and 67CFSR provide a clean air supply to a variety of pneumatic and electro-pneumatic instrumentation.
- **Digital Instrument Supply Regulator**—Designed to meet the accuracy, repeatability and hysteresis demands of digital instrumentation.
- **Pilot Supply Regulator**—Improves the accuracy of two-path control regulators by reducing inlet sensitivity caused by fluctuating inlet pressures.
- **Sour Gas Service Capability**—NACE MR0175 and MR0103 compliant construction available.
- **Optional Stainless Steel Construction**—The Types 67CS, 67CSR, 67CFS and 67CFSR provide high resistance to corrosion, which is especially beneficial for offshore applications.
- **Full Usable Capacity**—Fisher™ regulators are laboratory tested. 100% of the published capacities can be used with confidence.
- **Internal Relief**—The Types 67CR, 67CSR, 67CFR and 67CFSR have an internal relief valve with a soft seat

for reliable shutoff with no discernible leakage. These regulators are recommended for conserving plant air.

- **Smart Bleed™**—Opens to exhaust downstream pressure when inlet pressure drops below outlet pressure. Recommended for dead-end service.
- **Integral Filter**—The Types 67CF, 67CFR, 67CFS and 67CFSR have an integral filter ensuring clean downstream air supply.
- **Ease of Maintenance**—No special tools required to perform maintenance and all maintenance can be performed with the regulator in the line. Filter elements are easily replaced. The one-piece valve plug cartridge allows easy inspection and replacement.
- **Rugged Construction**—The 67C Series regulators are engineered for longer service life with minimal maintenance requirements.
- **Second Outlet**—Body side outlet for pressure gauge or other uses.
- **Powder Paint Coating**—Types 67C, 67CR, 67CF and 67CFR are powder paint coated, offering impact, abrasion and corrosion resistance. Stainless steel regulators (Types 67CS, 67CSR, 67CFS and 67CFSR) are not painted.
- **Corrosion Resistant Fasteners**—Bolting and adjusting screw are double zinc-chromated for enhanced corrosion resistance. Optional stainless steel bolting and adjusting screw are also available.

Principle of Operation (Figure 2)

Downstream pressure is registered internally on the lower side of the diaphragm. When the downstream pressure is at or above the set pressure, the valve plug is held against the orifice and there is no flow through the regulator. When demand increases, downstream pressure drops slightly allowing the spring to extend, moving the stem down and the valve plug away from the orifice. This allows flow through the regulator.

Inconel® is a marked own by Special Metals Corporation.

Bulletin 71.1:67C

Table 2. Available Constructions

| TYPE | CONSTRUCTION FEATURES | | OPTIONAL FEATURES | | | BODY MATERIAL | |
|--------|-----------------------|-------------|--|-------------|-------------|---------------|-----------------|
| | With Internal Relief | With Filter | Smart Bleed™ Internal Check Valve Airset | Drain Valve | Fixed Bleed | Aluminum | Stainless Steel |
| 67C | | | | | | X | |
| 67CR | X | | | | X | X | |
| 67CS | | | | | | | X |
| 67CSR | X | | | | X | | X |
| 67CF | | X | | X | | X | |
| 67CFR | X | X | X | X | X | X | |
| 67CFS | | X | | X | | | X |
| 67CFSR | X | X | X | X | X | | X |

Table 3. Construction Materials

| MATERIAL | TYPE | | | |
|---|---|--|--|--|
| | 67C and 67CR | 67CF and 67CFR | 67CS and 67CSR | 67CFS and 67CFSR |
| BODY AND SPRING CASE | Aluminum (ASTM B85/Alloy 380) | | CF8M/CF3M Stainless steel | |
| BOTTOM PLATE | 316 Stainless steel | ---- | 316 Stainless steel | ---- |
| PUSHER POST AND VALVE CARTRIDGE | Polyester resin | | | |
| UPPER SPRING SEAT | Zinc-plated steel | | 316 Stainless steel | |
| LOWER SPRING SEAT, DIAPHRAGM PLATE | Chromate conversion coated Aluminum | | 316 Stainless steel | |
| CONTROL SPRING | Plated Steel or Inconel® (NACE) | | Inconel® | |
| VALVE PLUG | Brass stem with Nitrile (NBR) plug, Aluminum stem with Nitrile (NBR) or Fluorocarbon (FKM) plug or Stainless steel stem with Nitrile (NBR) plug | | 316 Stainless steel stem with Nitrile (NBR) or Fluorocarbon (FKM) plug | |
| VALVE SPRING | Stainless steel or Inconel® (NACE) | | Inconel® | |
| DIAPHRAGM AND O-RINGS | Nitrile (NBR), Fluorocarbon (FKM) or Silicone (VMQ) ⁽¹⁾ | | | |
| SOFT SEAT AND GASKETS | Nitrile (NBR) or Fluorocarbon (FKM) | | | |
| BOLTING, ADJUSTING SCREW, LOCKNUT | Zinc-plated steel or Stainless steel | | Stainless steel | |
| HANDWHEEL | Zinc-plated steel screw with resin handwheel | | | |
| FILTER RETAINER | ---- | Plated Steel | ---- | 316 Stainless steel |
| FILTER ELEMENT | ---- | Polyethylene, Glass fiber, Stainless steel or PVDF (Plastic) | ---- | Polyethylene, Glass fiber, 316 Stainless steel or PVDF (Plastic) |
| DRAIN VALVE | ---- | Brass or Stainless steel | ---- | 316 Stainless steel or 18-8 Stainless steel |
| DRIPWELL | ---- | Aluminum (ASTM B85/Alloy 380) | ---- | CF8M/CF3M Stainless steel |

1. Silicone (VMQ) diaphragm is only available with internal relief (Types 67CR, 67CSR, 67CFR and 67CFSR).

Internal Relief (Types 67CR, 67CSR, 67CFR and 67CFSR)

If for some reason, outside of normal operating conditions, the downstream pressure exceeds the setpoint of the regulator, the force created by the downstream pressure will lift the diaphragm until the diaphragm is lifted off the relief seat. This allows flow through the token relief. The relief valve on the Type 67CR, 67CSR, 67CFR or 67CFSR is an elastomer plug that prevents leakage of air from the downstream to atmosphere during normal operation, thereby conserving plant air.

Smart Bleed Airset

In some cases, it is desired to exhaust downstream pressure if inlet pressure is lost or drops below the setpoint of the regulator. For example, if the regulator is installed on equipment that at times has no flow demand but is expected to backflow on loss of inlet pressure. The Type 67CFR or 67CFSR can be ordered with the Smart Bleed option which includes an internal check valve for this application. During operation, if inlet pressure is lost or decreases below the setpoint of the regulator, the downstream pressure will back flow upstream through the regulator and check valve. This option eliminates the need for a fixed bleed downstream of the regulator, thereby conserving plant air.

Inconel® is a marked own by Special Metals Corporation.

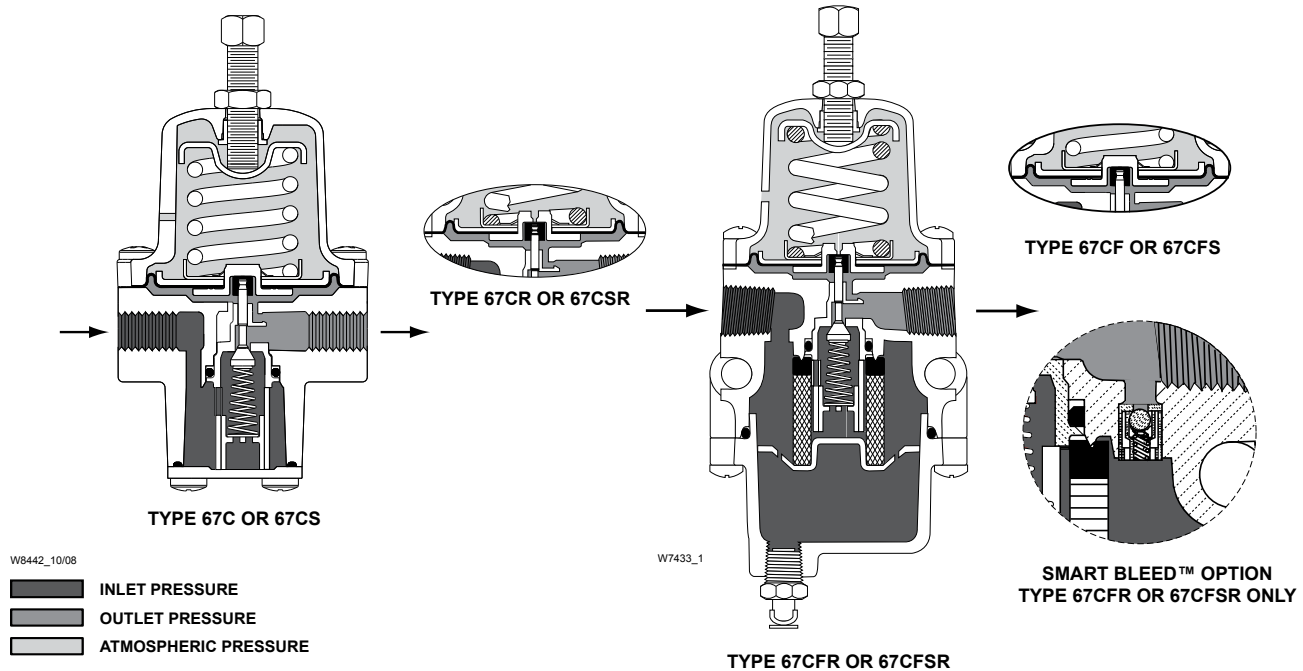

Figure 2. 67C Series Operational Schematics

Note

During normal operation the check valve's metal to metal seat allows limited flow through the regulator from the inlet to outlet, even when there is no downstream demand. To prevent downstream pressure buildup, the smart bleed option is only available with the internal relief version of the 67C Series.

Installation

The 67C Series regulators may be installed in any position but vertical orientation is recommended for 67C Series models with draining features. Spring case vents must be protected against the entrance of rain, snow, debris or any other foreign material that might plug the vent openings. The inlet connection is marked "In" and the two outlet connections are marked "Out". If a pressure gauge is not installed in one outlet connection, plug the unused connection. See Figures 5 to 9 for dimensions.

Emerson Process Management Regulator Technologies, Inc. (Emerson) provides an instruction manual with every regulator shipped. Refer to this for complete installation, operation and maintenance instructions. Included is a complete listing of individual parts and recommended spare parts.

Overpressure Protection

The 67C Series regulators have maximum outlet pressure ratings that are lower than their maximum inlet pressure ratings. A pressure-relieving or pressure-limiting device is needed if inlet pressure can exceed the maximum outlet pressure rating.

Types 67CR, 67CSR, 67CFR and 67CFSR regulators have a low capacity internal relief valve for minor seat leakage only. Other overpressure protection must be provided if the maximum inlet pressure can exceed the maximum pressure rating of the downstream equipment or exceeds maximum outlet pressure rating of the Type 67CR, 67CSR, 67CFR or 67CFSR regulator.

Overpressuring any portion of a regulator or associated equipment may cause leakage, parts damage or personal injury due to bursting of pressure-containing parts or explosion of accumulated gas. Regulator operation within ratings does not preclude the possibility of damage from external sources or from debris in the pipeline. A regulator should be inspected for damage periodically and after any overpressure condition.

Refer to the Capacity Information section and the Wide-Open Flow Coefficients for Relief Valve Sizing in the Specifications section on page 2 to determine the required relief valve capacity.

Capacity Information

Table 4 shows the air regulating capacities of the 67C Series regulators at selected inlet pressures and outlet pressure settings. Flows are shown in SCFH (at 60°F and 14.7 psia) and in Nm³/h (at 0°C and 1.01325 bar) of air.

Note

The 67C Series regulators may be sized for 100% flow using capacities as shown in Table 4. It is not necessary to reduce published capacities.

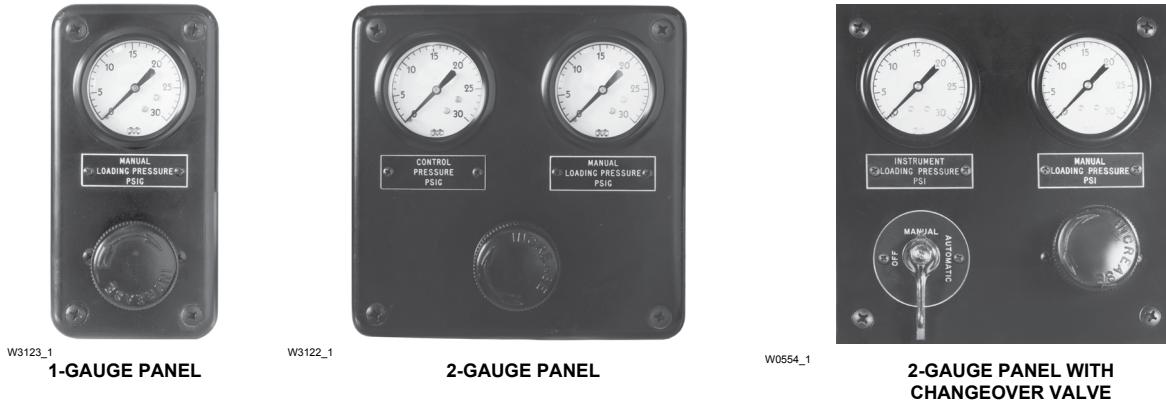

Figure 3. 670 Series Typical Panel Layouts

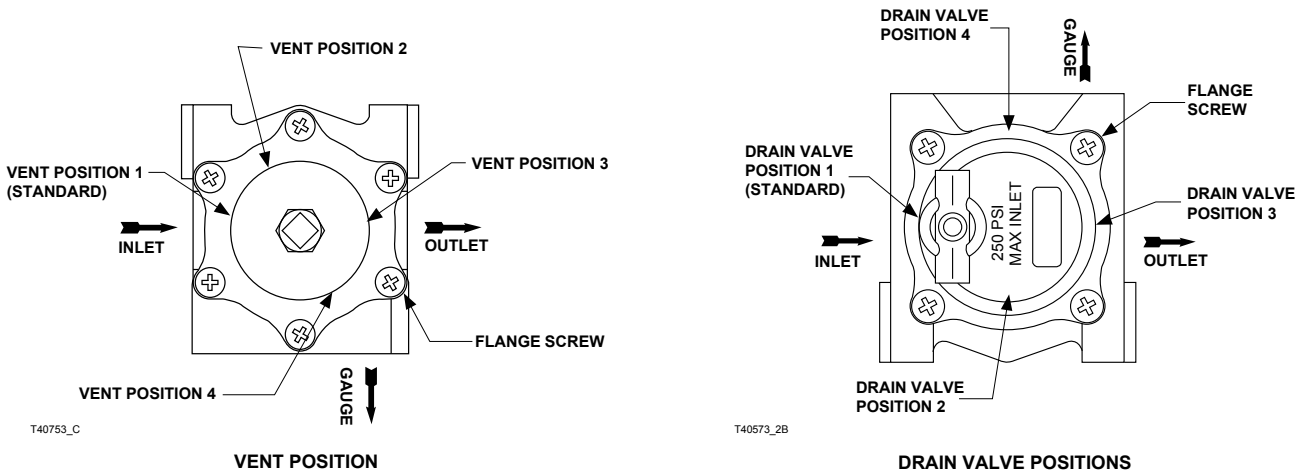

Figure 4. 67C Series Vent and Drain Valve Positions

To determine the equivalent capacities for other gases, multiply the table capacity by the following appropriate conversion factor: 1.29 for 0.6 specific gravity natural gas, 0.810 for propane, 0.707 for butane or 1.018 for nitrogen. For gases of other specific gravities, divide the table capacities by the square root of the appropriate specific gravity. To find wide-open flow capacities for relief sizing at any inlet pressure, perform one of the following procedures. Then, if necessary, convert using the factors provided above.

For critical pressure drops (absolute outlet pressure equal to or less than one-half of absolute inlet pressure), use the following formula:

$$Q = (P_1)(C_g)$$

For pressure drops lower than critical (absolute outlet pressure greater than one-half of absolute inlet pressure), use the following formula:

$$Q = \sqrt{\frac{520}{GT}} C_g P_1 \text{SIN} \left(\frac{3417}{C_1} \sqrt{\frac{\Delta P}{P_1}} \right) \text{DEG}$$

where,

- Q = gas flow rate, SCFH
- P₁ = absolute inlet pressure, psia (P₁ gauge + 14.7)
- C_g = gas sizing coefficient
- G = specific gravity of the gas
- T = absolute temperature of gas at inlet, °Rankine
- C₁ = flow coefficient (C_g ÷ C_v)
- ΔP = pressure drop across the regulator, psi

Then, if capacity is desired in normal cubic meters per hour (at 0°C and 1.01325 bar), multiply SCFH by 0.0268.

670 Series Panel-Mounted Loading Regulators (Figure 3)

The 670 Series panel-mounted loading regulators are compact, rugged units used primarily for manually loading pressure-balanced gas regulators and providing manual control for diaphragm actuator control valves. Applications include remote control of gas pressure to burners in refineries, power plants and various process furnaces.

Table 4. 67C Series Flow Capacities

| OUTLET PRESSURE RANGE, SPRING PART NUMBER AND COLOR CODE | OUTLET PRESSURE | | INLET PRESSURE | | CAPACITIES IN SCFH / Nm ³ /h OF AIR | | | | | | | |
|---|-----------------|------|---------------------|---------------------|--|--------------------|-----------|--------------------|-------------------------------------|--------------------|-----------|--------------------|
| | | | | | Types 67C, 67CR, 67CS and 67CSR | | | | Types 67CF, 67CFR, 67CFS and 67CFSR | | | |
| | | | | | 10% Droop | | 20% Droop | | 10% Droop | | 20% Droop | |
| | psig | bar | psig | bar | SCFH | Nm ³ /h | SCFH | Nm ³ /h | SCFH | Nm ³ /h | SCFH | Nm ³ /h |
| 0 to 35 psig / 0 to 2.4 bar T14059T0012 (Silver) T14113T0012 (Silver stripe) | 15 | 1.0 | 50 | 3.4 | 250 | 6.7 | 430 | 11.5 | 250 | 6.7 | 430 | 11.5 |
| | | | 75 | 5.2 | 340 | 9.1 | 610 | 16.3 | 300 | 8.0 | 690 | 18.5 |
| | | | 100 | 6.9 | 430 | 11.5 | 800 | 21.4 | 330 | 8.8 | 1000 | 26.8 |
| | | | 150 | 10.3 | 680 | 18.2 | 1200 | 32.2 | 400 | 10.7 | 1600 | 42.9 |
| | | | 250 | 17.2 | 1300 | 34.8 | 1900 | 50.9 | 450 | 12.1 | 1800 | 48.2 |
| | | | 400 | 27.6 ⁽¹⁾ | 390 | 10.5 | 1850 | 50.0 | ---- | ---- | ---- | ---- |
| | 20 | 1.4 | 50 | 3.4 | 310 | 8.3 | 460 | 12.3 | 350 | 9.4 | 500 | 13.4 |
| | | | 75 | 5.2 | 420 | 11.3 | 700 | 18.8 | 530 | 14.2 | 820 | 22.0 |
| | | | 100 | 6.9 | 620 | 16.6 | 940 | 25.2 | 750 | 20.1 | 1100 | 29.5 |
| | | | 150 | 10.3 | 960 | 25.7 | 1450 | 38.9 | 1400 | 37.5 | 1600 | 42.9 |
| | | | 250 | 17.2 | 1550 | 41.5 | 2150 | 57.6 | 2550 | 68.3 | 2700 | 72.4 |
| | | | 400 | 27.6 ⁽¹⁾ | 1200 | 32.2 | 2750 | 73.7 | ---- | ---- | ---- | ---- |
| 35 | 2.4 | 50 | 3.4 | 390 | 10.5 | 490 | 13.1 | 390 | 10.4 | 500 | 13.4 | |
| | | 75 | 5.2 | 590 | 15.8 | 850 | 22.8 | 640 | 17.2 | 820 | 22.0 | |
| | | 100 | 6.9 | 770 | 20.6 | 1150 | 30.8 | 840 | 22.5 | 1100 | 29.5 | |
| | | 150 | 10.3 | 1200 | 32.2 | 1750 | 46.9 | 1450 | 38.9 | 1650 | 42.9 | |
| | | 250 | 17.2 | 2200 | 58.9 | 2700 | 72.4 | 2450 | 65.7 | 2700 | 72.4 | |
| | | 400 | 27.6 ⁽¹⁾ | 2850 | 76.4 | 3450 | 92.5 | ---- | ---- | ---- | ---- | |
| 0 to 60 psig / 0 to 4.1 bar T14058T0012 (Blue stripe) T14114T0012 (Blue) | 35 | 2.4 | 50 | 3.4 | 310 | 8.3 | 440 | 11.8 | 330 | 8.8 | 470 | 12.6 |
| | | | 75 | 5.2 | 440 | 11.8 | 670 | 18.0 | 500 | 13.4 | 730 | 19.6 |
| | | | 100 | 6.9 | 560 | 15.0 | 900 | 24.1 | 700 | 18.8 | 1000 | 26.8 |
| | | | 150 | 10.3 | 780 | 20.9 | 1350 | 36.2 | 1050 | 28.1 | 1550 | 41.5 |
| | | | 250 | 17.2 | 1450 | 38.9 | 2200 | 59.0 | 2000 | 53.6 | 2600 | 69.7 |
| | | | 400 | 27.6 ⁽¹⁾ | 770 | 20.6 | 2500 | 67.0 | ---- | ---- | ---- | ---- |
| | 60 | 4.1 | 75 | 5.2 | 520 | 13.9 | 720 | 19.3 | 520 | 13.9 | 720 | 19.3 |
| | | | 100 | 6.9 | 750 | 20.1 | 1050 | 28.1 | 770 | 20.6 | 1000 | 26.8 |
| | | | 150 | 10.3 | 1100 | 29.5 | 1700 | 45.6 | 1100 | 29.5 | 1600 | 42.9 |
| | | | 250 | 17.2 | 2050 | 54.9 | 2850 | 76.4 | 2450 | 65.7 | 2750 | 73.7 |
| | | | 400 | 27.6 ⁽¹⁾ | 3200 | 85.8 | 4300 | 115 | ---- | ---- | ---- | ---- |
| | | | ---- | ---- | ---- | ---- | ---- | ---- | ---- | ---- | ---- | ---- |
| 0 to 125 psig / 0 to 8.6 bar T14060T0012 (Red stripe) T14115T0012 (Red) | 80 | 5.5 | 100 | 6.9 | 500 | 13.4 | 800 | 21.4 | 530 | 14.2 | 780 | 20.9 |
| | | | 150 | 10.3 | 750 | 20.1 | 1200 | 32.2 | 780 | 20.9 | 1200 | 32.2 |
| | | | 250 | 17.2 | 1200 | 32.2 | 2050 | 54.9 | 1250 | 33.5 | 2200 | 59.0 |
| | 125 | 8.6 | 150 | 10.3 | 900 | 24.1 | 1250 | 33.5 | 900 | 24.1 | 1150 | 30.8 |
| | | | 250 | 17.2 | 1560 | 41.8 | 2450 | 65.7 | 1650 | 44.2 | 2450 | 65.7 |
| | | | 400 | 27.6 ⁽¹⁾ | 2200 | 59.0 | 4350 | 117 | ---- | ---- | ---- | ---- |
| 0 to 150 psig / 0 to 10.3 bar ⁽²⁾ 10C1730X012 (Black) | 80 | 5.5 | 250 | 17.2 | 550 | 14.7 | 1200 | 32.2 | 550 | 14.7 | 1200 | 32.2 |
| | | | 400 | 27.6 ⁽¹⁾ | 400 | 10.7 | 1100 | 29.5 | ---- | ---- | ---- | ---- |
| | 135 | 9.3 | 250 | 17.2 | 970 | 26.0 | 1800 | 48.2 | 1100 | 29.5 | 1800 | 48.2 |
| | | | 400 | 27.6 ⁽¹⁾ | 840 | 22.5 | 2350 | 63.0 | ---- | ---- | ---- | ---- |
| | 150 | 10.3 | 250 | 17.2 | 1100 | 29.5 | 1850 | 49.6 | 1100 | 29.5 | 1850 | 49.6 |
| | | | 400 | 27.6 ⁽¹⁾ | 940 | 25.2 | 2500 | 67.0 | ---- | ---- | ---- | ---- |

1. Inlet pressures above 250 psig / 17.2 bar with a maximum of 400 psig / 27.6 bar are only available on Types 67CS and 67CSR.
2. Available for Types 67CS, 67CSR, 67CFS and 67CFSR only.

Three basic panels are available within the product line, each having one 67C Series pressure regulator connected to one or two gauges and a changeover valve.

A single gauge typically shows loading pressure to the control valve. For more information, see Bulletin 62.3:670.

NACE Universal Compliance

Optional materials are available for applications handling sour gases. These constructions comply with the recommendations of NACE International sour service standards.

The manufacturing processes and materials used by Emerson assure that all products specified for sour gas

service comply with the chemical, physical and metallurgical requirements of NACE MR0175 and/or NACE MR0103. Customers have the responsibility to specify correct materials. Environmental limitations may apply and shall be determined by the user.

Ordering Information

When ordering, complete the Ordering Guide on pages 11 and 12. Refer to the Specifications section on page 2. Review the description to the right of each specification and the information in each referenced table or figure. Specify your choice whenever a selection is offered.

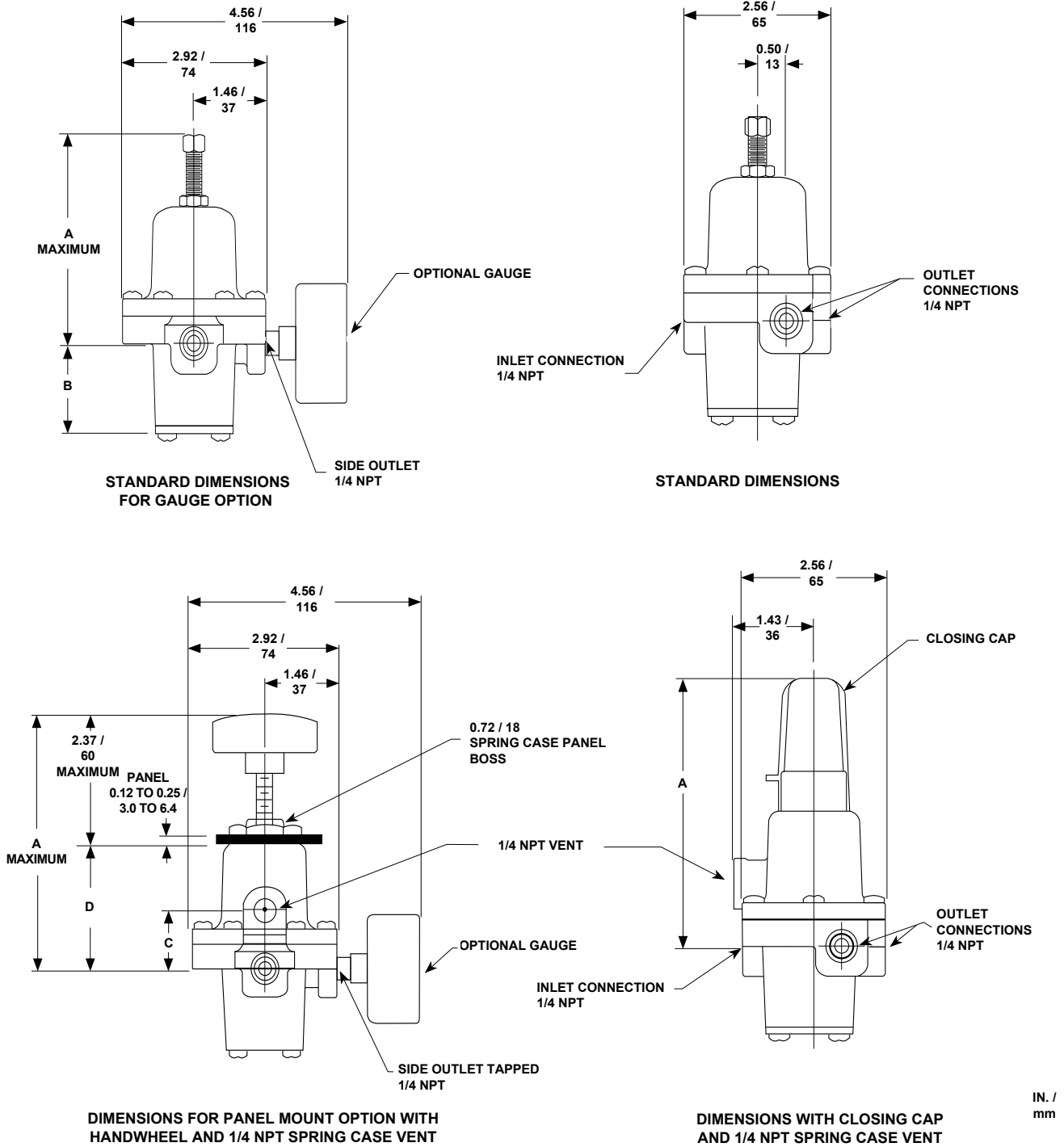

Figure 5. Types 67C, 67CR, 67CS and 67CSR Dimensions

Table 5. Types 67C, 67CR, 67CS and 67CSR Dimensions

| TYPE | STANDARD DIMENSION | | | | DIMENSION WITH CLOSING CAP | | PANEL MOUNT OPTION WITH HANDWHEEL DIMENSION | | | | | |
|----------------|--------------------|-----|------|----|----------------------------|-----|---|-----|------|----|------|----|
| | A | | B | | A | | A | | C | | D | |
| | In. | mm | In. | mm | In. | mm | In. | mm | In. | mm | In. | mm |
| 67C and 67CR | 3.50 | 89 | 1.51 | 38 | 4.60 | 117 | 4.69 | 119 | 1.08 | 27 | 2.33 | 59 |
| 67CS and 67CSR | 4.13 | 105 | 1.62 | 41 | 4.93 | 125 | 5.00 | 127 | 1.14 | 29 | 2.65 | 67 |

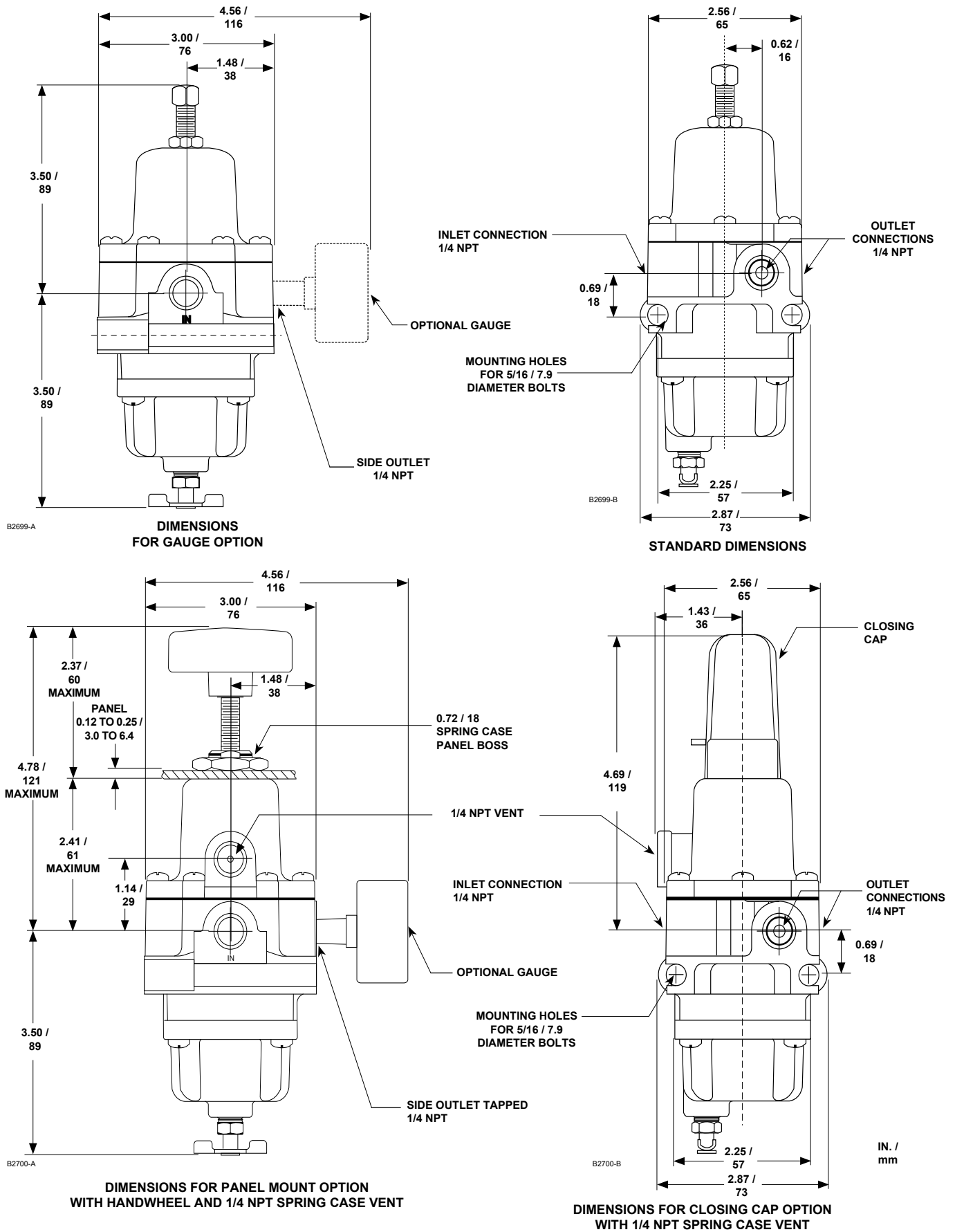

Figure 6. Types 67CF and 67CFR Dimensions

Bulletin 71.1:67C

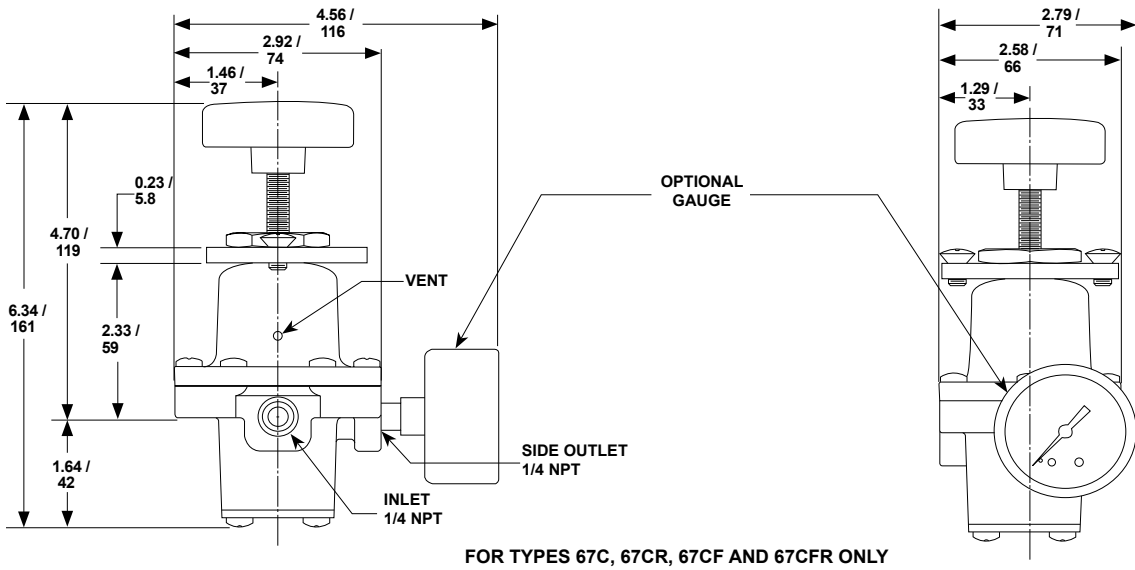

Figure 7. Dimensions for 3-Hole Panel Mount Option With Handwheel and 1/4 NPT Spring Case Vent

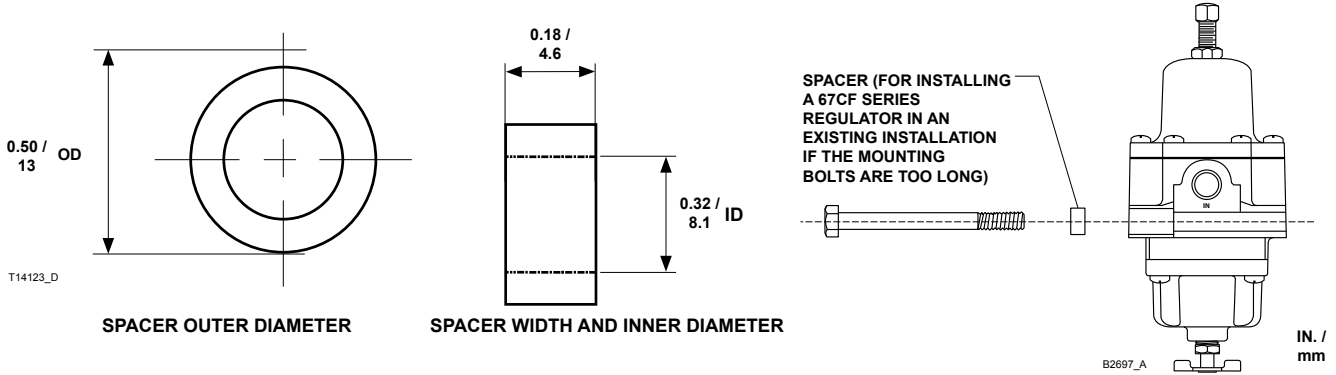

Figure 8. Spacer Dimensions and Installation Schematic

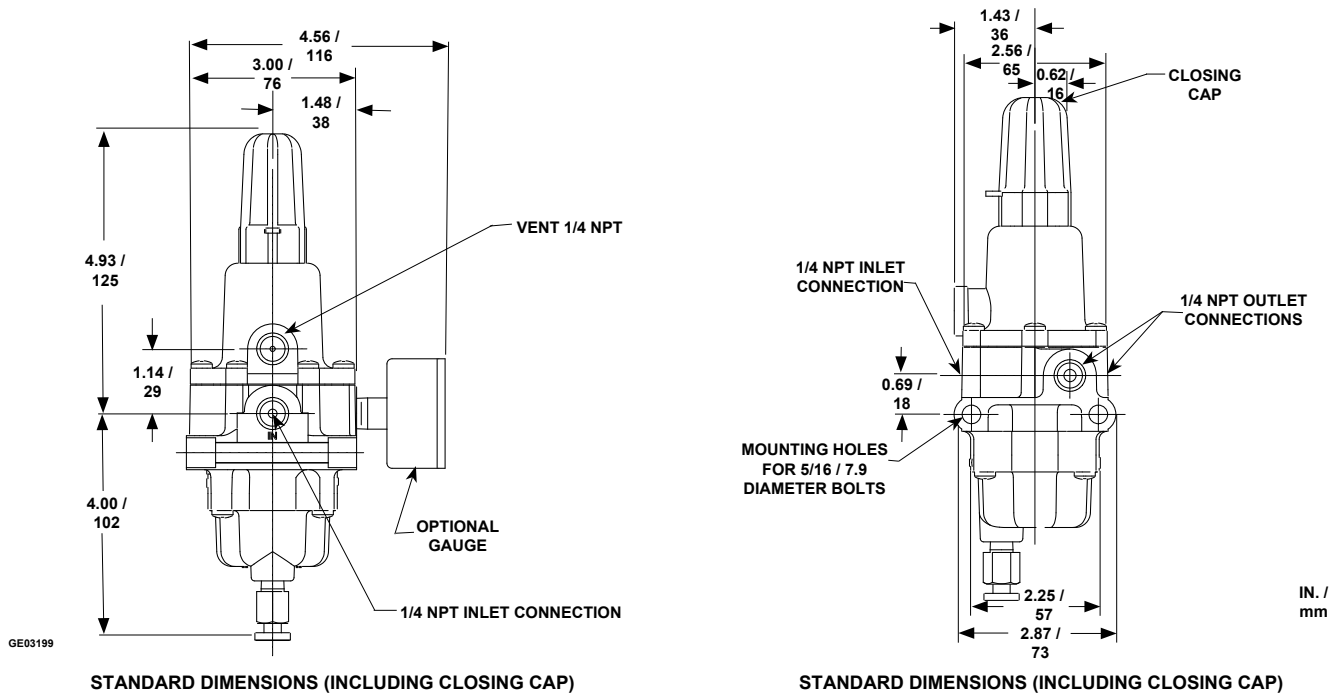

Figure 9. Types 67CFS and 67CF SR Dimensions