



Level



Pressure



Flow



Temperature

Liquid
Analysis

Registration

Systems
Components

Services



Solutions

Technical Information

Deltapilot M FMB50/51/52/53

Hydrostatic level measurement

Pressure sensor with the CONTITE™ measuring cell

Condensate-resistant offering long-term stability; HART communication.



Application

The hydrostatic pressure sensor is used for the following measuring tasks:

- Hydrostatic pressure measurement in liquids and paste-like media in all areas of process engineering, process measuring technology, pharmaceuticals and the food industry
- Level, volume or mass measurements in liquids

Your benefits

- Very good reproducibility and long-term stability
- Turn down 100:1
- Hermetically sealed CONTITE™ measuring cell:
 - Condensate-resistant and climatic-proofed
 - High reference accuracy: $\pm 0.2\%$, optionally $\pm 0.1\%$
 - Minimum temperature effects
- End-to-end modularity for differential pressure, hydrostatics and pressure (Deltabar M – Deltapilot M – Cerabar M), e.g.
 - replaceable display
 - universal electronics
- Easy commissioning without the need for an operating tool
- Menu-guided operation onsite via 4 to 20 mA with HART
- Wide range of approvals (e.g. ATEX, FM, CSA, etc.) for international use

Table of contents

Function and system design	4	Operating conditions (environment)	22
Device selection	4	Ambient temperature range	22
Measuring principle	6	Storage temperature range	22
Level measurement in closed tanks with pressure overlay	7	Degree of protection	22
Density measurement	7	Climate class	22
Level measurement with automatic density correction (with media changing in the tank)	8	Vibration resistance	22
Electrical differential pressure measurement with gauge pressure sensors	8	Electromagnetic compatibility	22
Communication protocol	8	Overvoltage protection (optional)	23
System integration	8	Operating conditions (process)	24
Input	9	Process temperature range	24
Measured variable	9	Lateral load FMB51 (static)	24
Measuring range	9	Pressure specifications	24
Explanation of terms	10	Mechanical construction	25
Output	11	F31 aluminum housing dimensions	25
Output signal	11	F15 stainless steel housing dimensions (hygienic)	25
Signal range – 4 to 20 mA HART	11	Process connections FMB50 (compact version)	25
Signal on alarm	11	Process connections FMB51 (rod version)	31
Load	11	Process connections FMB52 (cable version)	32
Resolution	11	Dimensions of Deltapilot M FMB53 (suspension clamp and mounting bracket)	33
Dynamic behavior: current output	12	Wall and pipe mounting with "Separate housing" version	34
Dynamic behavior: HART	12	Weight	35
Damping	12	Material	37
Power supply	13	Human interface	39
Electrical connection	13	Local operation	39
Supply voltage	15	Remote operation	41
Cable entry	15	Certificates and approvals	42
Cable specification	15	CE mark	42
Residual ripple	15	Ex approvals	42
Influence of power supply	15	Suitability for hygienic processes	42
Performance characteristics	16	Standards and guidelines	42
Reference operating conditions	16	Pressure Equipment Directive (PED)	42
Long-term stability	16	Drinking water approval	42
Influence of orientation	16	Ordering information	43
Calibration position	16	FMB50	43
Reference accuracy	16	FMB50 (continued)	44
Total performance	17	FMB50 (continued)	45
Total error	17	FMB50 (continued)	46
Thermal change in the zero output and the output span	17	FMB51	47
Operating conditions (installation)	18	FMB51 (continued)	48
General installation instructions	18	FMB51 (continued)	49
FMB50	18	FMB52	50
FMB51/FMB52/FMB53	18	FMB52 (continued)	51
Supplementary installation instructions	19	FMB52 (continued)	52
Wall and pipe mounting	19	FMB53	53
"Separate housing" version	20	FMB53 (continued)	54
Oxygen applications	21	FMB53 (continued)	55
Silicone-free applications	21	Documentation	56
Applications with hydrogen	21	Technical Information	56
Special measuring cells for acids, alkalis or sea water (not FMB50)	21	Operating Instructions	56
		Brief Operating Instructions	56

Safety Instructions	56
Installation/Control Drawings	57
Accessories	58
Suspension clamp (FMB53 only)	58
Extension cable shortening kit (FMB53 only)	58
M12 connector	58
Welding necks and Weld-in tool flanges	58
UNI process adapter	59
Configuration data sheet (HART)	60
Level	60
Pressure	61

Function and system design

Device selection

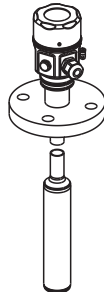
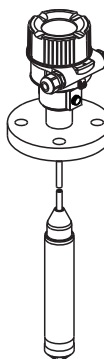
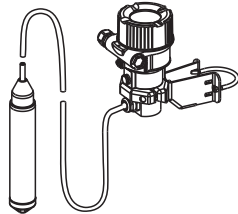
Deltapilot M – Product family	FMB50	FMB51	FMB52	FMB53
	 P01-FMB5xxxx-14-xx-xx-xx-000	 P01-FMB5xxxx-14-xx-xx-xx-001	 P01-FMB5xxxx-14-xx-xx-xx-002	 P01-FMB5xxxx-14-xx-xx-xx-003
	Compact version	Rod version	Cable version	Cable version with mounting clamp
Field of application	<ul style="list-style-type: none"> – Level measurement – Pressure measurement 			
Industries	Food, pharmaceuticals, chemicals			Environment (freshwater and wastewater)
Process connections	<ul style="list-style-type: none"> – Thread – Flanges – Flush-mounted hygienic connections 	<ul style="list-style-type: none"> – Thread – Flanges 	<ul style="list-style-type: none"> – Thread – Flanges 	Suspension clamp
Measuring ranges	From –0.1 to +0.1 (–1,45 to +1,45 psi) bar to –1 bar to +10 bar (–14,5 to 145 psi)			
OPL ¹⁾	Max. 40 bar (600 psi)			
Process temperature range	–10 to +100°C (+14 to +212°F) (+135°C (275°F) for 30 minutes maximum)	–10 to +85°C (+14 to +185°F)	With PE cable: –10 to +70°C (+14 to +158°F) With FEP cable: –10 to +80°C (+14 to +176°F)	
Ambient temperature range	<ul style="list-style-type: none"> ■ Without LCD display: –40 to +85°C (–40 to +185°F) ■ With LCD display: –20 to +70°C (–4 to +158°F) (extended temperature application range –40 to 85°C (–40 to +158°F) with restrictions in optical properties such as display speed and contrast) ■ Separate housing: –20 to +60°C (–4 to +140°F) 			
Reference accuracy	0.2 % (option 0.1 %) depends on the measuring range → 16			
Supply voltage	<ul style="list-style-type: none"> – 11.5 to 45 V DC (versions with plug-in connection 35 V DC) – For intrinsically safe device versions: 11.5 to 30 V DC 			
Output	4 to 20 mA with superimposed HART protocol			
Options	<ul style="list-style-type: none"> – Gold/rhodium-coated process isolating diaphragm – 3.1 inspection certificate – 3A approval and EHEDG approval for FMB50 (pending) – Specific firmware versions – Initial device settings can be ordered – Separate housing 			
Specialties	<ul style="list-style-type: none"> – Absolute resistance to condensate thanks to hermetically sealed CONTITE™ cell – Maximum flexibility thanks to modular design – Special cleaning of the transmitter to remove paint-wetting substances, for use in paint shops 			

1) OPL = over pressure limit; depends on the lowest-rated element, with regard to pressure, of the selected components

FMB50/51/52 universal application

- Modular probe program to ensure optimum process adaptation
- FMB50 compact version: installation in the tank from below or from the side
- FMB51/52 rod and cable extension: installation from above, i.e. easy to retrofit ground tanks, no additional opening in the tank floor



FMB50 optimized for the food-processing and pharmaceutical industry

- All typical flush-mounted process connections can be supplied
- Welding flanges
- Stainless steel housing
- All the sanitary process connections are gap-free and can be cleaned so that the unit is free of residue, e.g. CIP cleaning
- USDA/H1-approved transfer liquid as per FDA Directive
- 3A approval or EHEDG approvals (pending)



P01-DB5xxxxx-12-xx-xx-xx-004

FMB53 for level measurement in water and wastewater

- The housing with the electronic insert is mounted outside shafts and tanks in such a way that it is protected from flooding. The extension cable is secured with a suspension clamp.
- The measuring cell tube made of stainless steel (AISI 316L) and the Alloy process isolating diaphragm allow use in aggressive media such as wastewater for example.
- Extension cable up to 400 m (1312 ft) in length (up to 100 m (328 ft) in Ex-areas) without strain relief.
- Special measuring cell with gold/rhodium coating for applications in which severe hydrogen formation can occur (e.g. digested sludge); →  21.
- Special measuring cell with gold/platinum coating for acids, alkalis or sea water; →  21.

Measuring principle

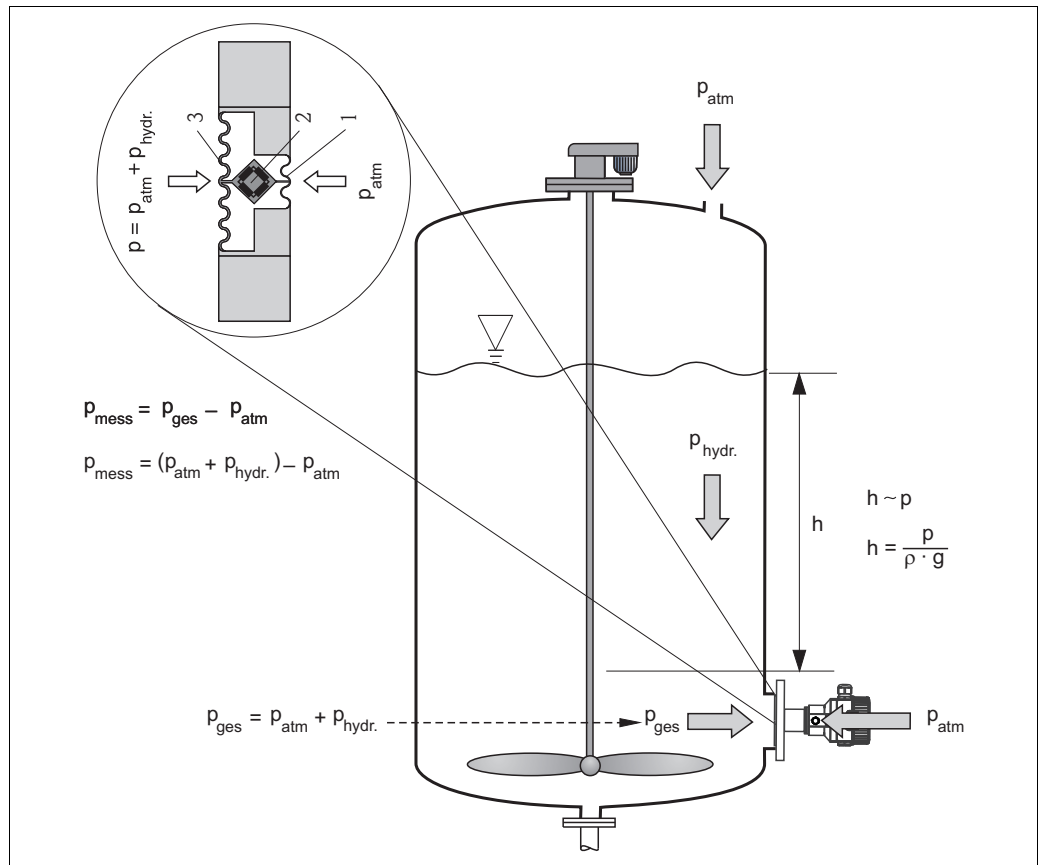
*Deltapilot M hydrostatic level measurement and measuring principle*

- 1 Rear isolating membrane of the CONTITE™ measuring cell
 - 2 Measuring element
 - 3 Process isolating diaphragm
- g Gravitational acceleration
 - h Level height
 - p_{ges} Total pressure = hydrostatic pressure + atmospheric pressure
 - p_{atm} Atmospheric pressure
 - $p_{hydr.}$ Hydrostatic pressure
 - p_{mess} Measured pressure in the measuring cell = hydrostatic pressure
 - ρ Density of the medium

Due to its weight, a liquid column creates hydrostatic pressure. If the density is constant, the hydrostatic pressure depends solely on the height h of the liquid column.

The CONTITE™ measuring cell, which works on the principle of the gauge pressure sensor, constitutes the core of Deltapilot M. In contrast to conventional gauge pressure sensors, the precision measuring element (2) in the CONTITE™ measuring cell is absolutely protected, situated between the process isolating diaphragm (3) and the rear isolating membrane (1). Thanks to this hermetic sealing of the measuring element, the CONTITE™ measuring cell is absolutely insensitive to condensate/condensation and aggressive gases. The pressure applied is transferred from the process isolating diaphragm to the measuring element by means of an oil without any loss in pressure.

Two temperature sensors, which measure the distribution of temperature in the cell, are arranged between the process isolating diaphragm and measuring element. The electronics can compensate any measuring errors resulting from fluctuations in temperature with these measured temperature values.

A linearization function with max. 32 points, based on a table entered either manually or semi-automatically, can be activated locally or remotely. This function facilitates measurement in engineering units, and provides a linear output signal for spherical and horizontal cylindrical tanks, and vessels with a conical outlet.

Level measurement in closed tanks with pressure overlay

You can determine the differential pressure in tanks with pressure overlay using two Deltapilot M. The pressure measured values of the two probes are sent to a signal processing unit such as Endress+Hauser RMA or a PLC. The signal processing unit or PLC determines the difference in pressure and uses this to calculate the level and the density where necessary.

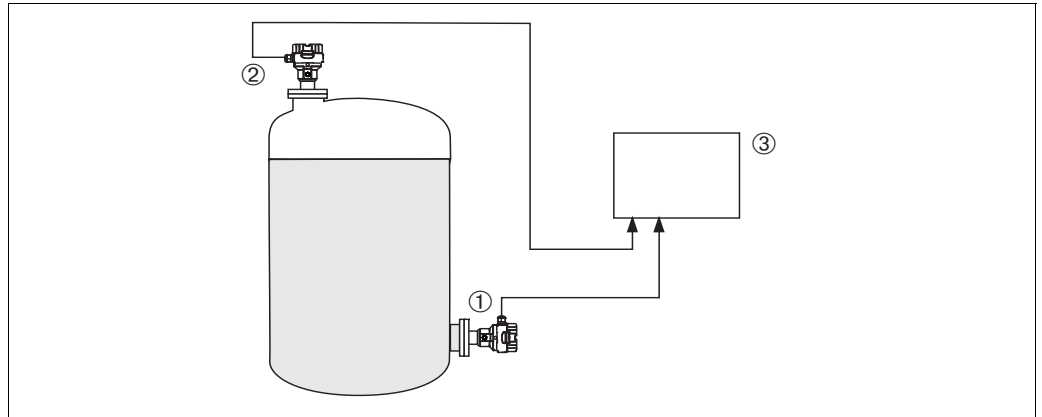

P01-FMB5xxxx-15-xx-xx-xx-005

Level measurement in a closed tank with pressure overlay

- 1 Probe 1 measures the total pressure (hydrostatic pressure and top pressure)
- 2 Probe 2 measures the top pressure
- 3 Signal processing unit determines the difference in pressure and uses this to calculate the level

Note!

- When selecting the Deltapilot M probes, make sure you select measuring ranges that are sufficiently wide (→ see example).
- The process isolating diaphragm of probe 2 must not be flooded. This generates additional hydrostatic pressure which distorts the measurement.
- The ratio of hydrostatic pressure to top pressure should be no more than 1:6.

Example:

- Max. hydrostatic pressure = 0.6 bar (9 psi)
- Max. top pressure (probe 2) = 0.3 bar (4.5 psi)
- Max. total pressure, measured with probe 1 = 0.3 bar (4.5 psi) + 0.6 bar (9 psi) = 0.9 bar (13.5 psi)
⇒ Measuring cell to be selected: 0 to 1.2 bar (0 to 18 psi)
- Max. pressure, measured with probe 2: 0.3 bar (4.5 psi)
⇒ Measuring cell to be selected: 0 to 0.4 bar (0 to 6 psi)

Density measurement

You can measure the density in tanks with pressure overlay using two Deltapilot M and a signal processing unit or a PLC. The signal processing unit or the PLC calculates the density from the known distance Δh between the two probes and the two measured values p_1 and p_2 .

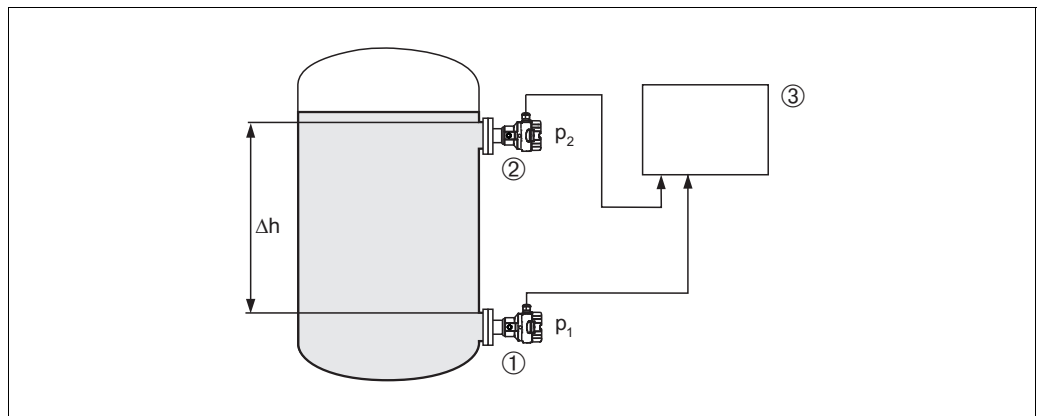

P01-FMB5xxxx-15-xx-xx-xx-005

Level measurement in a closed tank with pressure overlay

- 1 Deltapilot M determines pressure measured value p_1
- 2 Deltapilot M determines pressure measured value p_2
- 3 Signal processing unit determines the density from the two measured values p_1 and p_2 and the distance Δh

Level measurement with automatic density correction (with media changing in the tank)

Level measurement with automatic density correction is possible in conjunction with a limit switch such as Liquiphant and a PLC. The limit switch always switches at the same level. In the switch point, the signal processing unit determines the corrected density from the pressure of the Deltapilot M currently measured and the known distance between Deltapilot M and the limit switch. The signal processing unit then calculates the level from the new density and the measured pressure of the Deltapilot M.

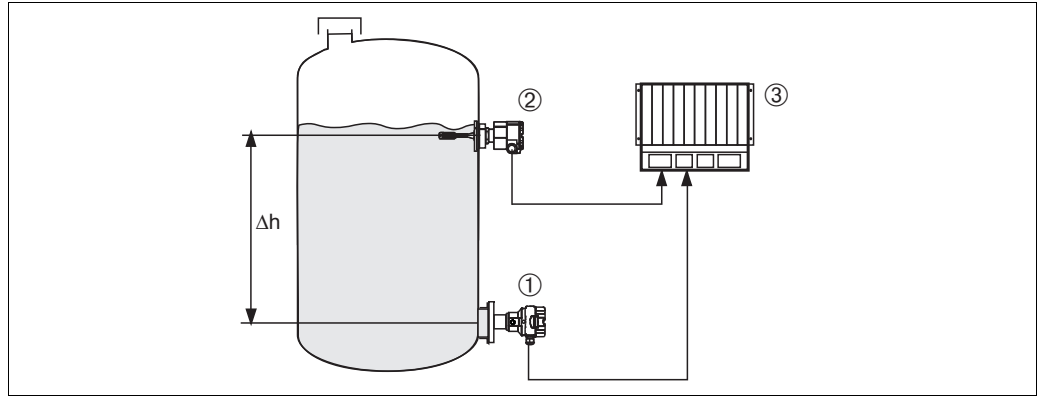

P01-FMB5xxxx-15-xx-xx-xx-007

Level measurement with automatic density correction

- 1 Deltapilot M
- 2 Liquiphant
- 3 PLC

Electrical differential pressure measurement with gauge pressure sensors

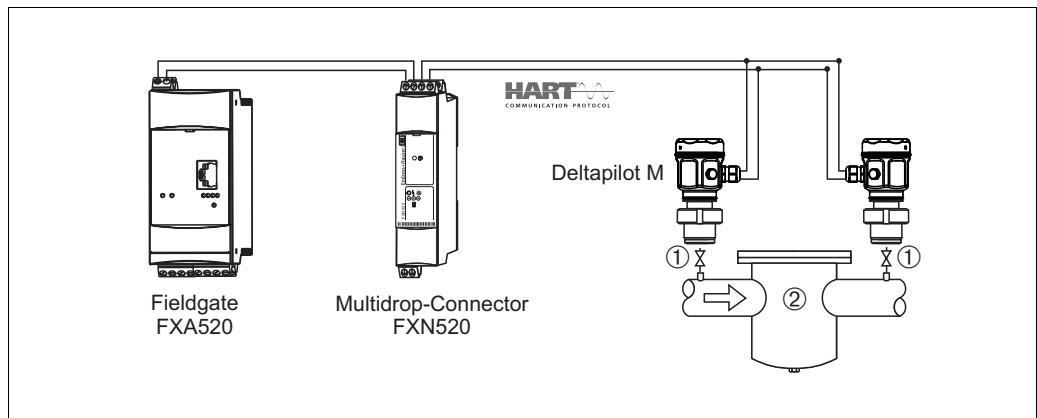

P01-FMB5xxxx-14-xx-xx-xx-004

- 1 Shut-off valves
- 2 e.g. filter

In the example given, two Deltapilot M devices (each with a gauge pressure sensor) are interconnected. The pressure difference can thus be measured using two independent Deltapilot M devices.



Caution!

If using intrinsically safe devices, strict compliance with the rules for interconnecting intrinsically safe circuits as stipulated in IEC60079-14 (proof of intrinsic safety) is mandatory.

Communication protocol

- 4 to 20 mA with HART communication protocol

System integration

The device can be fitted with a tag name and a preset bus address, see → 43 ff "Ordering information" feature 895 "Identification:" version "Z1" and "Z2".

Input

Measured variable Hydrostatic pressure

Measuring range

Nominal value	Range limit		Smallest span (factory calibration) ¹⁾	MWP ²⁾	OPL ³⁾	Vacuum resistance ⁴⁾ Synthetic oil/ Inert oil [bar _{abs} (psi _{abs})]	Version in the order code ⁵⁾
	lower (LRL) ⁶⁾	upper (URL)					
[bar (psi)]	[bar (psi)]	[bar (psi)]	[bar (psi)]	[bar (psi)]	[bar (psi)]		
0.1 (1.45)	-0.1 (-1.5)	+0.1 (+1.5)	0.01 (0.15)	2.7 (40.5)	4 (60)	0.01/0.04 (0,15/0,6)	1C
0.4 (6)	-0.4 (-6)	+0.4 (+6)	0.02 (0.3)	5.3 (79.5)	8 (120)		1F
1.2 (18)	-1 (-15)	+1.2 (+18)	0.06 (1)	16 (240)	24 (360)		1H
4 (60)	-1 (-15)	+4 (+60)	0.2 (3)	16 (240)	24 (360)		1M
10 (150)	-1 (-15)	+10 (+150)	0.5 (7.5)	27 (405)	40 (600)		1P

- 1) Recommended Turn down: Max 100:1.
Factory calibration Turn down: Max 20:1, higher on request.
- 2) The MWP (maximum working pressure) for the measuring device depends on the lowest-rated element, with regard to pressure, of the selected components, i.e. the process connection (→ 25 ff) has to be taken into consideration in addition to the measuring cell (→ see Table above). Pay attention to the pressure-temperature dependence also. For the appropriate standards and other information, see → 24, Pressure specifications section.
- 3) OPL: over pressure limit; depends on the lowest-rated element, with regard to pressure, of the selected components
- 4) The vacuum resistance applies to the measuring cell at reference conditions.
- 5) → 43 ff, "Ordering information" section, feature 70 "Sensor range"
- 6) By default, the device is set to a lower range limit of 0 bar. Please specify in the order if the lower range limit is to be set to a different default value.

Explanation of terms

Explanation of terms: turn down (TD), set span and span based on zero point

Case 1:

- Lower range value (LRV) \leq Upper range value (URV)

Example:

- Lower range value (LRV) = 0 mbar
- Upper range value (URV) = 40 mbar (0.6 psi)
- Nominal value (URL) = 400 mbar (6 psi)

Turn down:

- $TD = URL / |URV| = 10:1$

Set span:

- $URV - LRV = 40 \text{ mbar (0.6 psi)}$
- This span is based on the zero point.

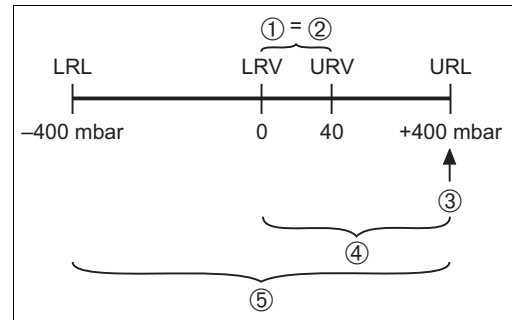

P01-DBxxxxxx-05-xx-xx-xx-001

Example: 400 mbar (6 psi) measuring cell

Case 2:

- Lower range value (LRV) \geq Upper range value (URV)

Example:

- Lower range value (LRV) = -200 mbar (3 psi)
- Upper range value (URV) = 0 bar
- Nominal value (URL) = 400 mbar (6 psi)

Turn down:

- $TD = URL / |LRV| = 2:1$

Set span:

- $URV - LRV = 200 \text{ mbar (3 psi)}$
- This span is based on the zero point.

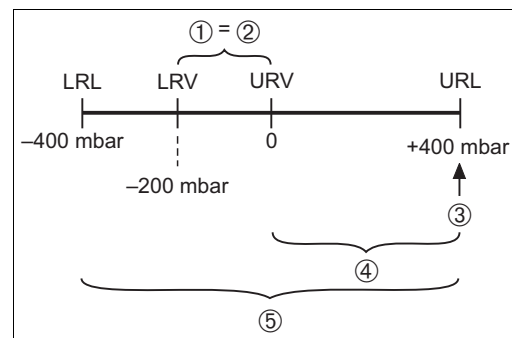

P01-DBxxxxxx-05-xx-xx-xx-002

Example: 400 mbar (6 psi) measuring cell

- Set span
 - Span based on zero point
 - Nominal value \cong upper range limit (URL)
 - Nominal measuring range
 - Sensor measuring range
- LRL Lower range limit
 URL Upper range limit
 LRV Lower range value
 URV Upper range value

Output

Output signal ■ 4 to 20 mA with superimposed digital communication protocol HART 6.0, 2-wire

**Signal range –
4 to 20 mA HART** 3.8 to 20.5 mA

Signal on alarm As per NAMUR NE 43

- 4 to 20 mA HART
- Options:
 - Max. alarm: can be set from 21 to 23 mA (Factory setting: 22 mA)
 - Hold measured value: last measured value is held
 - Min. alarm: 3.6 mA

Load

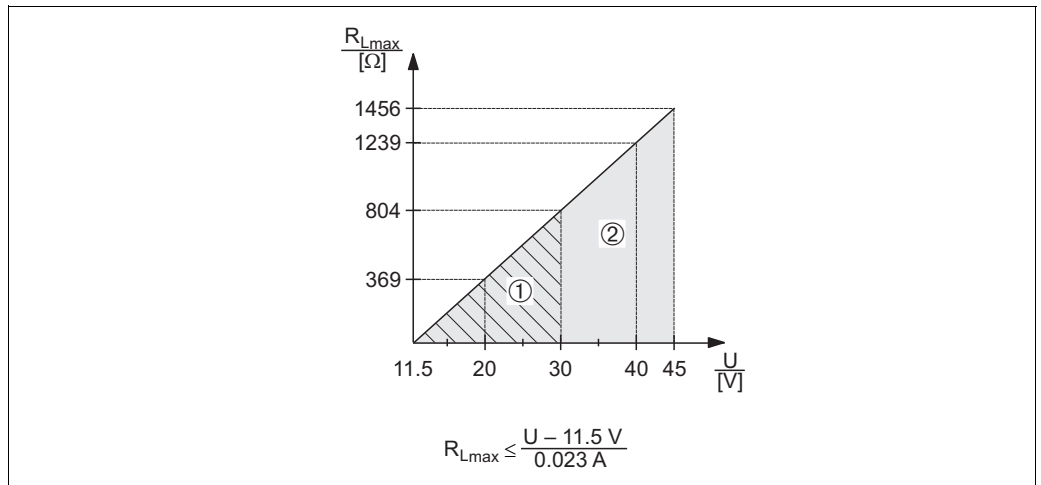

P01-xxxxxxx-05-xx-xx-xx-002

Load diagram

- 1 Power supply 11.5 to 30 V DC for intrinsically safe device versions
- 2 Power supply 11.5 to 45 V DC (versions with plug-in connector 35 V DC) for other types of protection and for uncertified device versions

R_{Lmax} Maximum load resistance
 U Supply voltage

Note!

When operating via a handheld terminal or via a PC with an operating program, a minimum communication resistance of 250 Ω must be taken into account.

Resolution ■ Current output: 1 μA
 ■ Display: can be set (factory setting: presentation of the maximum accuracy of the transmitter)

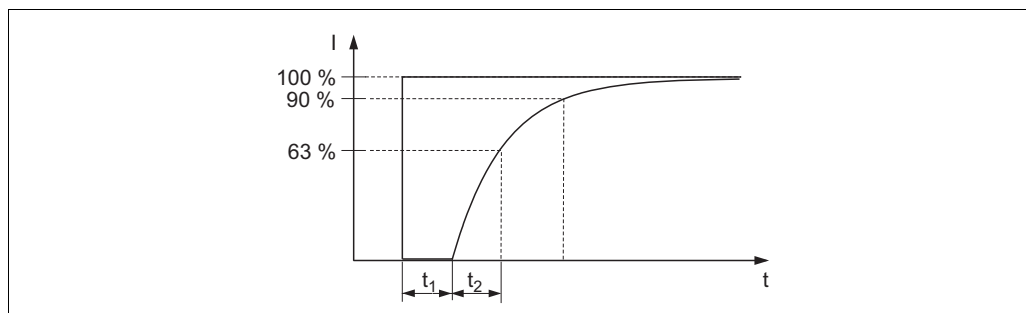
**Dynamic behavior:
current output****Dead time, time constant (T63)**

P01-xxxxxxx-05-xx-xx-xx-007

Presentation of the dead time and the time constant

Type	Dead time t_1 [ms]	Time constant (T63), t_2 [ms]
FMB50	< 55	< 65
FMB51/52/53	< 500	< 250

Dynamic behavior: HART**Dead time, time constant (T63)**

A typical configuration for the PLC of 2 to 3 values per second results in the following total dead time:

Type	Dead time t_1 [ms]	Time constant (T63), t_2 [ms]
FMB50	305	< 65
FMB51/52/53	750	< 250

Reading cycle

HART commands: 2 to 3 per second on average.

The Deltapilot M commands the BURST MODE function for cyclic value transmission via the HART communication protocol.

Response time

≤ 250 ms

Cycle time (update time)

On average 310 to 520 ms.

Damping

A damping affects all outputs (output signal, display).

- Via local display, handheld terminal or PC with operating program, continuous from 0 to 999 s
- Additionally for HART: via DIP switch on the electronic insert, switch position "on" = value set in the software (factory setting: 2 s) and "off"

Power supply

Electrical connection

Note!

- When using the measuring device in hazardous areas, installation must comply with the corresponding national standards and regulations and the Safety Instructions or Installation or Control Drawings.
→ 56 ff, "Safety Instructions" and "Installation/Control Drawings" sections.
- Overvoltage protection HAW569Z for the non-hazardous area and for ATEX II 1/2 G Exi can be ordered as an option (see "Ordering information" section).
- Protective circuits against reverse polarity, HF influences and overvoltage peaks are installed.

4 to 20 mA HART

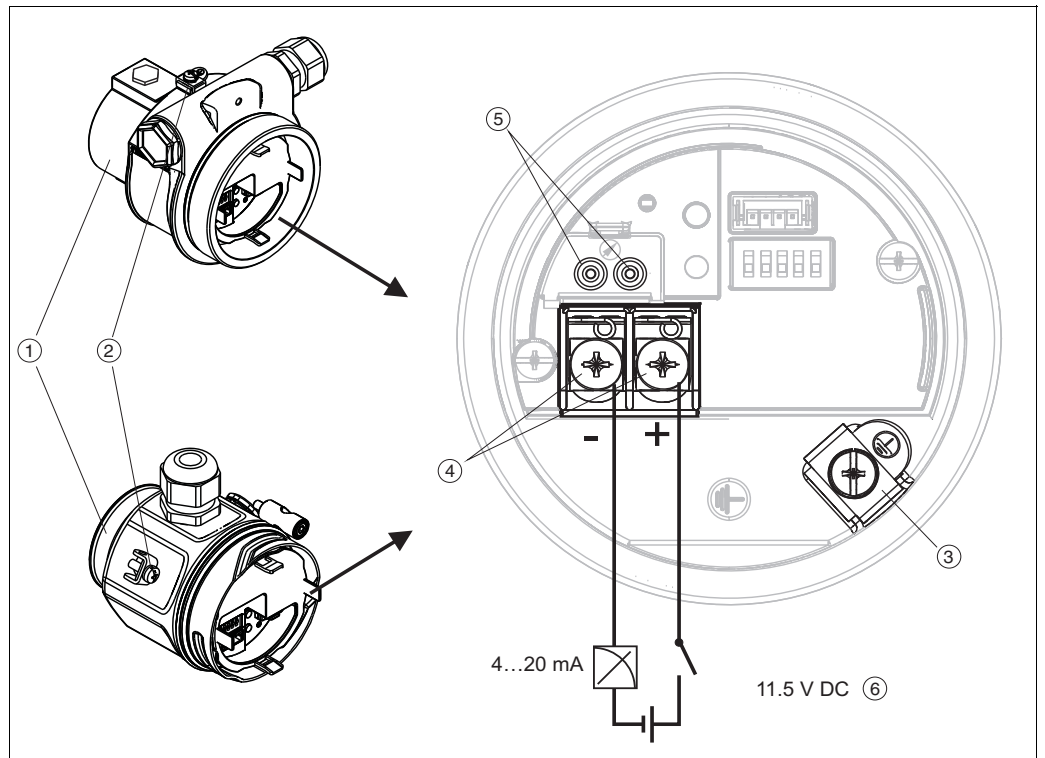

Electrical connection 4 to 20 mA HART

- 1 Housing
- 2 External ground terminal
- 3 Internal ground terminal
- 4 Power supply terminals
- 5 Test terminals, see "Taking 4 to 20 mA test signal"
- 6 Minimum supply voltage = 11.5 V DC

Taking 4 to 20 mA test signal

A 4 to 20 mA test signal may be measured via the test terminals without interrupting the measurement.

Devices with valve connector

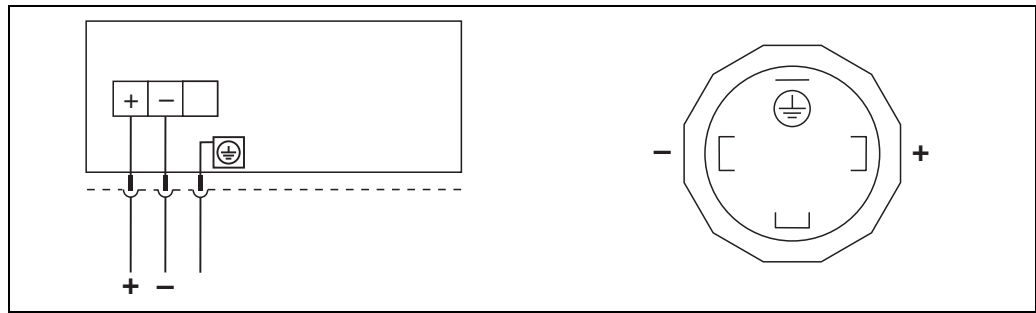

P01-xxxx5xxxx-04-xx-xx-xx-005

Left: electrical connection for devices with a valve connector
Right: view of the connector at the device

Devices with Harting connector Han7D

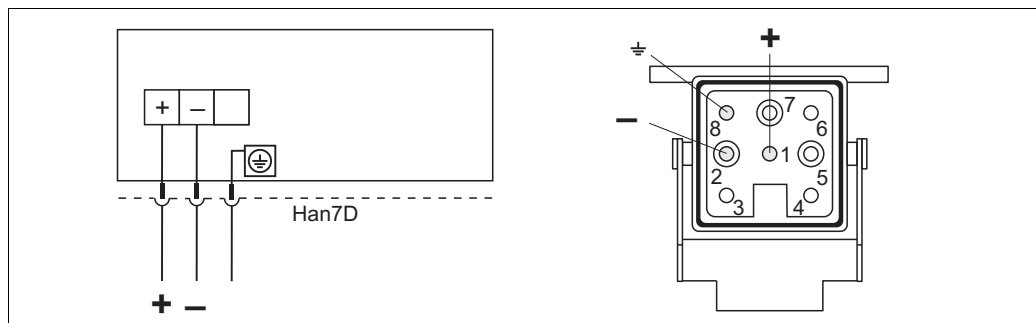

P01-xxxx7xxxx-04-xx-xx-xx-001

Left: electrical connection for devices with a Harting connector Han7D
Right: view of the connection at the device

Devices with M12 connector

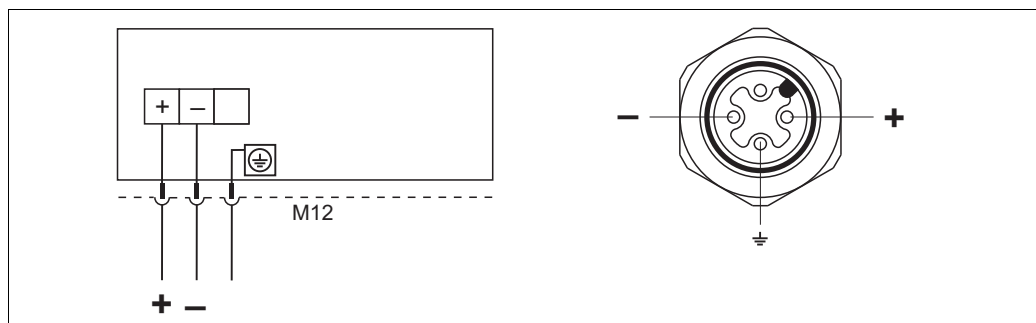

P01-xxxx7xxxx-04-xx-xx-xx-000

Left: electrical connection for devices with an M12 connector
Right: view of the connector at the device

Endress+Hauser offers the following accessories for devices with an M12 connector:

Plug-in jack M 12x1, straight

- Material: body PA; coupling nut CuZn, nickel-plated
- Degree of protection (fully locked): IP67
- Order number: 52006263 or through device order, see also → 43 ff "Ordering information" section

Plug-in jack M 12x1, elbowed

- Material: body PBT; coupling nut GD-Zn, nickel-plated
- Degree of protection (in screwed situation): IP67
- Order number: 71091284 or through device order, see also → 43 ff "Ordering information" section

Cable 4x0.34 mm² (20 AWG) with M12 socket, elbowed, screw plug, 5 m (16 ft) length

- Material: body PUR; coupling nut CuSn/Ni; cable PVC
- Degree of protection (fully locked): IP67
- Order number: 52010285 or through device order, see also → 43 ff "Ordering information" section

Devices with 7/8" connector

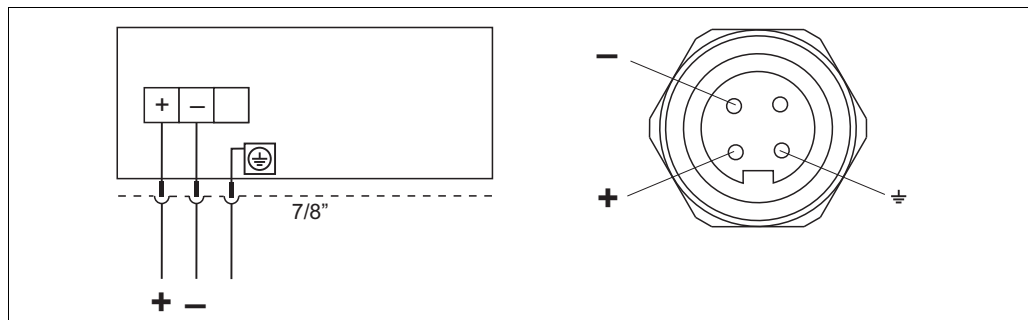

Left: electrical connection for devices with a 7/8" connector
 Right: view of the connector at the device

P01-xxxx/xxxx-04-xx-xx-xx-003

Cable gland

Approval	Type	Clamping area
Standard, CSA GP ATEX II1/2G or II2G Ex ia, IEC Ex ia Ga/Gb or Ex ia Gb, FM/ CSA IS	Plastic M20x1.5	5 to 10 mm (0,2 to 0,39 in)
ATEX II1/2D Ex t, II1/2GD Ex ia, II3G Ex nA, IEC Ex t Da/Db	Metal M20x1.5 (Ex e)	7 to 10.5 mm (0,28 to 0,41 in)

Terminals

For wire cross-sections of 0.5 to 2.5 mm² (20 to 14 AWG)

Supply voltage

Note!

- When using the measuring device in hazardous areas, installation must comply with the corresponding national standards and regulations and the Safety Instructions or Installation or Control Drawings.
- All explosion protection data are given in separate documentation which is available upon request. The Ex documentation is supplied as standard with all devices approved for use in explosion hazardous areas. → 56 ff, "Safety Instructions" and "Installation/Control Drawings" sections.

4 to 20 mA HART

- 11.5 to 45 V DC
(Versions with plug-in connection 35 V DC)
- For intrinsically safe device versions: 11,5...30 V DC

Cable entry

→ 43 ff, feature 50 "Electrical connection".

Cable specification

- Endress+Hauser recommends using twisted, shielded two-wire cables.
- Terminals for wire cross-sections 0.5 to 2.5 mm² (20 to 14 AWG)
- Cable outer diameter: 5 to 9 mm (0.2 to 0.35 in)

Residual ripple

No influence on 4 to 20 mA signal up to ± 5 % residual ripple within the permitted voltage range [according to HART hardware specification HCF_SPEC-54 (DIN IEC 60381-1)]

Influence of power supply

≤ 0.0006 % of URL/1 V

Performance characteristics

Reference operating conditions

- As per IEC 60770
- Ambient temperature T_A = constant, in the range of: +21 to +33°C (+70 to 91 °F)
- Humidity φ = constant, in the range of: 5 to 80 % RH
- Ambient pressure p_A = constant, in the range of: 860 to 1060 mbar (12.47 to 15.37 psi)
- Position of the measuring cell: constant, in range:
 - FMB50: horizontally $\pm 1^\circ$
 - FMB51/FMB52/FMB53: vertically $\pm 1^\circ$
- Input of LOW SENSOR TRIM and HIGH SENSOR TRIM for lower range value and upper range value
- Span based on zero point
- Material of the process isolating diaphragm: Alloy C276 (2.4819) and Alloy C276 with coating (AuRh or AuPt)
- Measuring cell material (meter body): Alloy C276, 316L/1.4435
- Filling oil: synthetic oil (FDA)/inert oil
- Supply voltage: 24 V DC \pm 3 V DC
- Load with HART: 250 Ω
- HART warm-up period:
 - FMB50 = <5 s
 - FMB51/FMB52/FMB53 = <8 s

Long-term stability

Measuring cell	Long-term stability [%]
0.1 bar (1,5 psi)	<ul style="list-style-type: none"> ■ < 0.18 of the upper range limit (URL) / year ■ < 0.45 of the upper range limit (URL) / 5 years
0.4 bar (6 psi) 1.2 bar (18 psi)	<ul style="list-style-type: none"> ■ < 0.1 of the upper range limit (URL) / year ■ < 0.25 of the upper range limit (URL) / 5 years
4 bar (60 psi) 10 bar (150 psi)	<ul style="list-style-type: none"> ■ < 0.05 of the upper range limit (URL) / year ■ < 0.125 of the upper range limit (URL) / 5 years

Influence of orientation

- < 2.3 mbar (0.0345 psi) when using synthetic oil (FDA)
- < 5 mbar (0.075 psi) when using inert oil

Note!

Position-dependent zero point shift can be corrected. →  18, "General installation instructions" section.

Calibration position

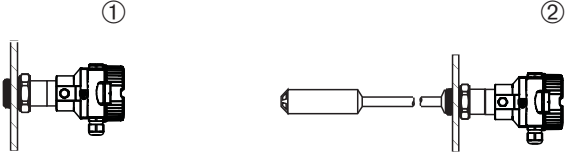
<p>① FMB50</p> <p>② FMB51, FMB52, FMB53 To minimize the effect of the orientation (e.g. in the case of vertical device installation), position offset is preset at the factory.</p>	
---	--

P01-FMB5xxxx-11-xx-xx-xx-001

Reference accuracy

The reference accuracy comprises the non-linearity according to limit point setting, hysteresis and non-reproducibility as per IEC 60770. The data refer to the calibrated span.

Reference accuracy in % of the calibrated span			
Measuring cell	TD	"Standard" option	"Platinum" option
0.1 bar (1.5 psi)	TD \leq 2:1 TD > 2:1	< 0.2 < 0.1 x TD	< 0.15 < 0.075 x TD
0.4 bar (6 psi)	TD \leq 4:1 TD > 4:1	< 0.2 < 0.05 x TD	< 0.15 < 0.0375 x TD

Reference accuracy in % of the calibrated span			
Measuring cell	TD	"Standard" option	"Platinum" option
1.2 bar (18 psi)	TD ≤ 2:1 TD > 2:1	< 0.2 < 0.1 x TD	< 0.1 < 0.05 x TD
4 bar (60 psi)	TD ≤ 4:1 TD > 4:1	< 0.2 < 0.05 x TD	< 0.1 < 0.025 x TD
10 bar (150 psi)	TD ≤ 2.5:1 TD > 2.5:1	< 0.2 < 0.08 x TD	< 0.1 < 0.04 x TD

Total performance

The "Total performance" specification comprises the non-linearity including hysteresis, non-reproducibility as well as the thermal change in the zero point.

Total performance in % of the URL				
Version	Measuring cell	-10 to +60°C (+14 to +140 °F)	60 to 85°C (140 to 185 °F)	85 to 100 C (185 to 212 °F)
FMB50 FMB51/52/53 snap-on	0.1 bar (1.5 psi)	< 0.35	< 0.45	< 0.6
FMB51/52/53 welded	0.1 bar (1.5 psi)	< 0.8	< 1	< 1.4
FMB50/51/52/53	0.4 bar (6 psi)	< 0.35	< 0.45	< 0.6
	1.2 bar (18 psi), 4 bar (60 psi), 10 bar (150 psi)	< 0.15	< 0.2	< 0.25

Total error

The total error comprises the long-term stability and the total performance:

Measuring cell	% of the URL/year (in the permitted temperature range)
0.1 bar (1.5 psi)	<ul style="list-style-type: none"> ■ Snap-on: ±0.63 ■ Welded: ±1.0
0.4 bar (6 psi)	■ ±0.61
1.2 bar (18 psi)	■ ±0.27
4 bar (60 psi), 10 bar (150 psi)	■ ±0.25

Thermal change in the zero output and the output span

Thermal change in % of the calibrated span				
Version	Measuring cell	-10 to +60°C (-94 to +752°F)	60 to 85 °C (+140 to +185°F)	85 to 100 °C (+140 to +185°F)
FMB50 FMB51/52/53 snap-on	0.1 bar (1.5 psi)	< (0.32 + 0.30 x TD)	< (0.34 + 0.40 x TD)	< (0.34 + 0.55 x TD)
FMB51/52/53 welded	0.1 bar (1.5 psi)	< (0.32 + 0.50 x TD)	< (0.34 + 0.60 x TD)	< (0.36 + 0.70 x TD)
FMB50/51/52/53	0.4 bar (6 psi)	< (0.31 + 0.25 x TD)	< (0.32 + 0.30 x TD)	< (0.33 + 0.35 x TD)
	1.2 bar (18 psi), 4 bar (60 psi), 10 bar (150 psi)	< (0.31 + 0.10 x TD)	< (0.32 + 0.15 x TD)	< (0.33 + 0.20 x TD)

Operating conditions (installation)

General installation instructions

- The position-dependent zero point shift can be corrected:
 - directly at the device via an operating key
 - directly at the device via operating keys on the display
 - via digital communication if the cover is not open
- Note!
In hazardous areas, comply strictly with the safety instructions when the housing cover is closed and open.
- The local display can be rotated in 90° stages.

FMB50

Level measurement

- Always install the device below the lowest measuring point.
- Do not install the device at the following positions:
 - in the filling curtain
 - in the tank outflow
 - or at a point in the tank that can be affected by pressure pulses from the agitator
- The calibration and functional test can be carried out more easily if you mount the device downstream of a shutoff device.
- Deltapilot M must be included in the insulation for media that can harden when cold.

Pressure measurement in gases

- Mount Deltapilot M with shutoff device above the tapping point so that any condensate can flow into the process.

Pressure measurement in steams

- Mount Deltapilot M with siphon below the tapping point.
- Fill the siphon with liquid before commissioning.
The siphon reduces the temperature to almost the ambient temperature.

Pressure measurement in liquids

- Mount Deltapilot M with the shutoff device below or at the same level as the tapping point.

FMB51/FMB52/FMB53

- When mounting rod and cable versions, make sure that the probe head is located at a point as free as possible from flow. To protect the probe from impact resulting from lateral movement, mount the probe in a guide tube (preferably made of plastic) or secure it with a clamping fixture.
- In the case of devices for hazardous areas, comply strictly with the safety instructions when the housing cover is open.
- The length of the extension cable or the probe rod is based on the planned level zero point. The top of the probe should be at least 5 cm (1.97 in) below this.
- Suspension clamp (FMB53 only)
Material: Edelstahl AISI 316L (1.4435), clamping jaw: fiberglass reinforced PA (polyamide)
Order number: 52010869
→  43 ff, feature 620, "Accessory enclosed", version "PO".

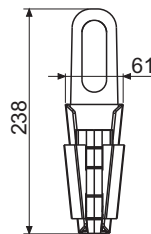

Supplementary installation instructions**Process isolating diaphragm**

- Do not clean or touch process isolating diaphragms with hard or pointed objects.
- The process isolating diaphragm in the rod and cable version is protected against mechanical damage by a plastic cap.

Seal

- Deltapilot M devices with a G 1 1/2 thread:
When screwing the device into the tank, the flat seal has to be positioned on the sealing surface of the process connection. To avoid additional strain on the process isolating diaphragm, the thread should never be sealed with hemp or similar materials.
- Deltapilot M devices with NPT threads:
 - Wrap Teflon tape around the thread to seal it.
 - Tighten the device at the hexagonal bolt only. Do not turn the device at the housing.
 - Do not overtighten the thread when screwing in the screw. Max. torque: 20 to 30 Nm (14.75 to 22.13 lbf ft)

Sealing the probe housing

Moisture must not penetrate the housing when mounting the device, establishing the electrical connection and during operation.

- Always firmly tighten the housing cover and the cable entries.
- Lubricant is provided on the O-ring seal in the housing cover and on the thread of the aluminum cover. To ensure that the cover seals tight, any lubricant which has been removed must be replaced. Use silicone grease or graphite paste as the lubricant. Mineral oil-based grease can destroy the O-ring.



Cable length tolerances

- FMB52
 - Cable length < 5 m (16 ft): up to -35 mm (-1.38 in)
 - Cable length > 5 m (16 ft): up to -100 mm (-3.94 in)
 - Cable length > 100 m (328 ft): up to -250 mm (-9,84 in)
- FMB53
 - Cable length < 5 m (16 ft): up to ±17,5 mm (±0.69 in)
 - Cable length > 5 m (16 ft): up to ±50 mm (±1.97 in)
 - Cable length > 100 m (328 ft): up to ±125 mm (±4,92 in)

Rod length tolerances

- FMB51
 - Rod length < 4000 mm (157 in): up to ±4 mm (±0,16 in)

Wall and pipe mounting

Endress+Hauser offers a mounting bracket for installing the device on pipes or walls
→  43 ff, feature 620, "Accessory enclosed", version "PA" or as separate accessory (part no.: 71102216).
For the dimensions, →  34.

"Separate housing" version

With the "separate housing" version, you are able to mount the housing with the electronics insert at a distance from the measuring point. This allows for trouble-free measurement:

- Under particularly difficult measuring conditions (at installation locations that are cramped or difficult to access)
- If rapid cleaning of the measuring point is required
- If the measuring point is exposed to vibrations

You can choose between different cable versions:

- PE (2 m (6.6 ft), 5 m (16 ft) and 10 m (33 ft))
- FEP (5 m (16 ft)).

→  43 ff, feature 600, "Separate housing".

For the dimensions, see →  34.

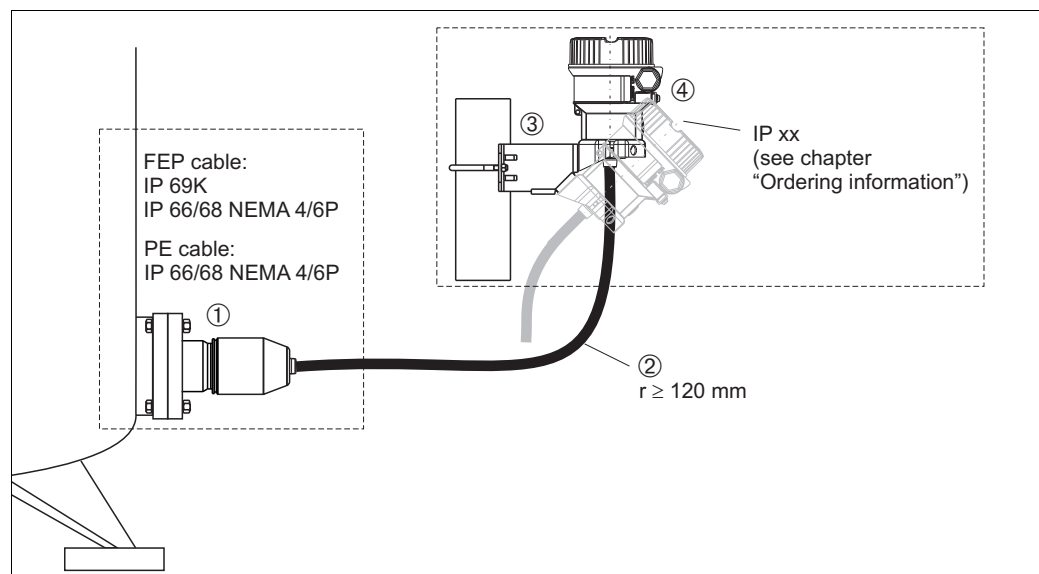

P01-PMx5xxxx-11-xx-xx-en-002

In the case of the "separate housing" version, the sensor is delivered with the process connection and cable ready mounted. The housing and a mounting bracket are enclosed as separate units. The cable is provided with a socket at both ends. These sockets are simply connected to the housing and the sensor.

- 1 Process connection with sensor
- 2 Cable, both ends are fitted with a socket
- 3 Mounting bracket provided, suitable for pipe and wall mounting (for pipes with 2" diameter)
- 4 Housing with electronic insert

Degree of protection for the process connection and sensor when using:

- FEP cable:
 - IP 69K
 - IP 66/68 NEMA 4/6P
- PE cable:
 - IP 66/68 NEMA 4/6P

Technical data of the PE and FEP cable:

- Minimum bending radius: 120 mm (4.72 in)
- Cable extraction force: max. 450 N (101 lbf)
- Resistance to UV light

Use in hazardous area:

- Intrinsically safe installations (Ex ia/IS)
- FM/CSA IS: for Div.1 installation only

Installation conditions

General conditions

- Installation without insulation
- Ambient temperature: max. 50°C (122°F)

Oxygen applications

Oxygen and other gases can react explosively to oils, grease and plastics. As a result, the following are some of the precautions that must be taken:

- All components of the system, such as measuring devices, must be cleaned in accordance with the BAM (DIN 19247) requirements.
- Depending on the materials used, a certain maximum temperature and maximum pressure must not be exceeded for oxygen applications. The maximum temperature T_{\max} for oxygen applications is 60°C (140°F).

The devices suitable for gaseous oxygen applications are listed in the following table with the specification p_{\max} .

Order code for devices ¹⁾ cleaned for oxygen applications	p_{\max} for oxygen applications
FMB50 ²⁾	<ul style="list-style-type: none"> ■ Depends on the lowest-rated element, with regard to pressure, of the selected components: over pressure limit (OPL) of the sensor or process connection (1.5 x PN)³⁾ ■ Depends on filling oil⁴⁾
FMB51 ²⁾	<ul style="list-style-type: none"> ■ Depends on the lowest-rated element, with regard to pressure, of the selected components: over pressure limit (OPL) of the sensor or process connection (1.5 x PN)³⁾ ■ Depends on filling oil⁴⁾ ■ Depends on seal material

- 1) Only device, not accessory or enclosed accessory
- 2) Feature 570 "Service" version "HB"
- 3) → 9, "Measuring range" section and → 25 ff, "Mechanical construction" section
- 4) Oxygen applications possible with FKM seal and inert oil.

Silicone-free applications

Special cleaning of the transmitter to remove paint-wetting substances, for use in paint shops → 43 ff feature 570 "Service", version "HC".

Applications with hydrogen

With regard to materials in which hydrogen formation takes place (e.g. digested sludge), hydrogen atoms can diffuse through the metal process isolating diaphragm. This can result in incorrect measurement results. Endress+Hauser offers process isolating diaphragms with a gold/rhodium coating for such instances.

→ Order via feature 170 "Material of the process isolating diaphragm", version "L".

Note!

To reduce the formation of hydrogen, you should not use galvanized assemblies.

Special measuring cells for acids, alkalis or sea water (not FMB50)

For acids, alkalis or sea water, Endress+Hauser offers process isolating diaphragms with a gold/platinum coating.

Note!

With temperature exposure (up to 85 °C (185 °F)) there is an additional zero point deviation of 1,1 mbar (0,0165 psi).

→ Order via feature 170 "Material of the process isolating diaphragm", version "N".

Operating conditions (environment)

Ambient temperature range

Version	FMB50	FMB51	FMB52	FMB53
Without LCD display	-40°C to +85°C (-40°F to +185°F)		With PE cable: -40°C to +70°C (-40°F to +158°F) With FEP cable: -40°C to +80°C (-40°F to +176°F)	
With LCD display ¹⁾	-20°C to +70°C (-4°F to +158°F)			
With M12 plug , elbowed	-25°C to +85°C (-13°F to +185°F)		With PE cable: -25°C to +70°C (-13°F to +158°F) With FEP cable: -25°C to +80°C (-13°F to +176°F)	
With separate housing (PE and FEP cable)	-20°C to +60 °C (-4°F to +140°F)			

- 1) Extended temperature application range (-40°C to +85°C (-40°F to +185°F)) with restrictions in optical properties such as display speed and contrast

Storage temperature range

Version	FMB50	FMB51	FMB52	FMB53
Without LCD display	-40°C to +90°C (-40°F to +194 °F)		With PE cable: -40°C to +70°C (-40°F to +158°F) With FEP cable: -40°C to +80°C (-40°F to +176°F)	
With LCD display	-40°C to +85°C (-40°F to +185°F)			
With M12 plug , elbowed	-25°C to +90°C (-13°F to +194°F)		With PE cable: -25°C to +70°C (-13°F to +158°F) With FEP cable: -25°C to +80°C (-13°F to +176°F)	
With separate housing and FEP cable	-20°C to +60°C (-4°F to +140°F)			

Degree of protection

- → ☞ 43 ff, feature 50 "Electrical connection".
- Separate housing → ☞ 20

Climate class

Class 4K4H (air temperature: -20 to 55°C (-4 to +131°F), relative humidity: 4 to 100%) satisfied as per DIN EN 60721-3-4 (condensation possible)

Vibration resistance

Device/accessory	Test standard	Vibration resistance
FMB50	GL VI-7-2 <ul style="list-style-type: none"> ■ Part 7: Guidelines for the Performance of Type Approvals ■ Chapter 2: Test Requirements for Electrical / Electronic Equipment and Systems 	Guaranteed for: 3 to 25 Hz: ±1.6 mm (0.06 in); 25 to 100 Hz: 4 g in all 3 planes
■ FMB50	IEC 61298-3 IEC 60068-2-6	Guaranteed for: 10 to 60 Hz: ±0.15 mm (0.01 in); 60 to 500 Hz: 2 g in all 3 planes
FMB51, FMB52, FMB53		Guaranteed for: 10 to Hz: 0,075 mm (0.003 in) 60...150 Hz 1g in all 3 planes

Electromagnetic compatibility

- Electromagnetic compatibility as per all the relevant requirements of the EN 61326 series and NAMUR Recommendation EMC (NE21). Details can be found in the Declaration of Conformity (in the Download area of "www.de.endress.com", "search area - Approvals and Certificates", "Manufact. Declaration").
- Maximum deviation: < 0.5 % of the span to turn down (TD) = 2:1
- All measurements were performed with a turn down (TD) = 2:1.

Overvoltage protection (optional)

The device can be fitted with overvoltage protection, see → 43 ff "Ordering information" feature 610 "Accessory mounted:" version "NA". The overvoltage protection is mounted at the factory on the housing thread (M20x1.5) for the cable gland and is approx. 70 mm (2.76 in) in length (take additional length into account when installing). The device is connected as illustrated in the following graphic. For details refer to TI103R/09/EN, XA036R/09/A3 and KA161R/09/A6.

Wiring

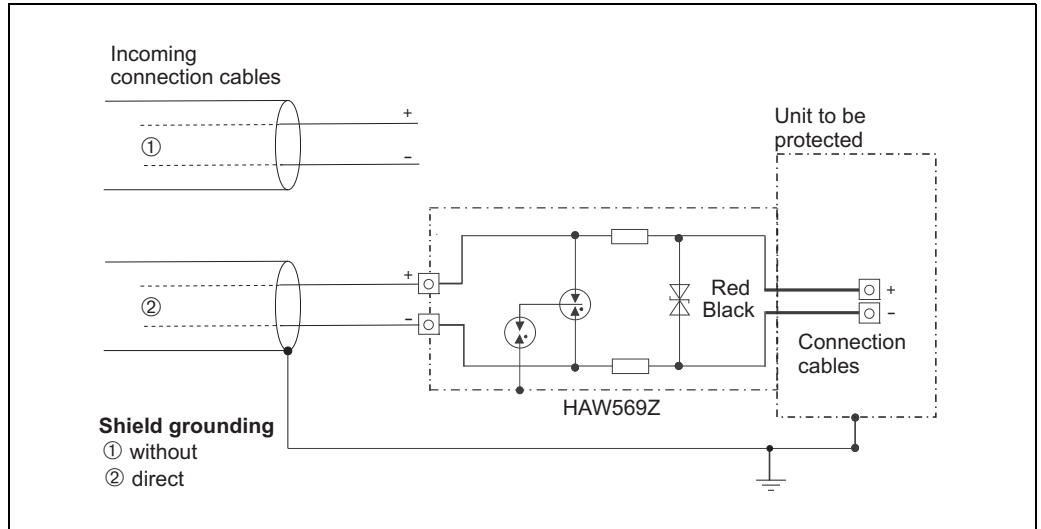

Operating conditions (process)

Process temperature range

FMB50	FMB51	FMB52	FMB53
-10°C to +100°C (+14°F to 212°F) 135°C (275°F) for 30 min. maximum	-10°C to +85°C (+14°F to +185°F)	With PE cable: -10°C to +70°C (-14°F to 158°F) With FEP cable: -10°C to +80°C (-14°F to 176°F)	

Lateral load FMB51 (static)

≤30 Nm

Pressure specifications

- The maximum pressure for the measuring device depends on the lowest-rated element with regard to pressure. See the following sections:
 - → 9 ff, "Measuring range" section
 - "Mechanical construction" section.
 The MWP (maximum working pressure) is specified on the nameplate. This value refers to a reference temperature of +20°C (68°F) or 100°F (38°C) for ANSI flanges and may be applied to the device for an unlimited time. Pay attention to pressure-temperature dependencies.
 - The pressure values permitted at higher temperatures can be found in the following standards:
 - EN 1092-1: 2001 Tab. 18¹
 - ASME B 16.5a – 1998 Tab. 2-2.2 F316
 - ASME B 16.5a – 1998 Tab. 2.3.8 N10276
 - JIS B 2220.
 - The test pressure corresponds to the over pressure limit of the device (OPL = 1.5 x MWP) and may be applied for only a limited time period in order to avoid permanent damage.
 - The Pressure Equipment Directive (EC Directive 97/23/EC) uses the abbreviation "PS". The abbreviation "PS" corresponds to the MWP (maximum working pressure) of the measuring device.
 - In the case of sensor range and process connection combinations where the OPL (over pressure limit) of the process connection is smaller than the nominal value of the sensor, the device is set at the factory, at the very maximum, to the OPL value of the process connection. If you want to use the entire sensor range, select a process connection with a higher OPL value (1.5 x PN; PN = MWP).
 - In oxygen applications, the values for "p_{max} and T_{max} for oxygen applications" as per → 21, "Oxygen applications" may not be exceeded.
- 1) With regard to their stability-temperature property, the materials 1.4435 and 1.4404 are grouped together under 13EO in EN 1092-1 Tab. 18. The chemical composition of the two materials can be identical.

Mechanical construction

F31 aluminum housing dimensions

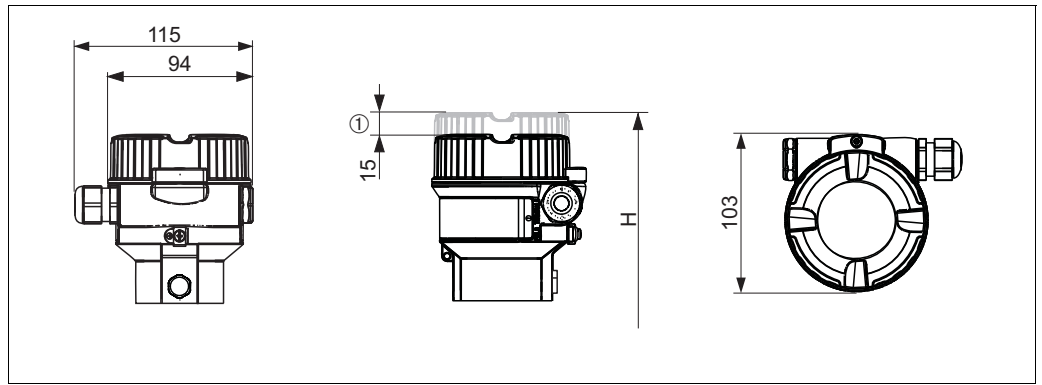

Front view, left-hand side view, top view

① The cover with viewing window is 15 mm (0,59 in) higher than the cover without viewing window.

→ For installation height H for housing with viewing window, see the specific process connection. Housing weight

→ 35

F15 stainless steel housing dimensions (hygienic)

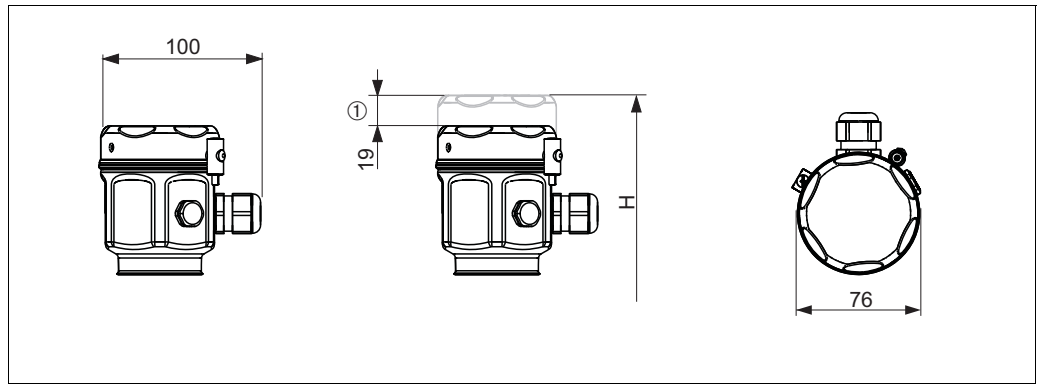

Front view, top view.

① The cover with viewing window is 19 mm (0,75 in) higher than the cover without viewing window.

→ For installation height H for housing with viewing window, see the specific process connection. Housing weight

→ 35

Process connections FMB50 (compact version)

Threaded connection ISO 228 and NPT

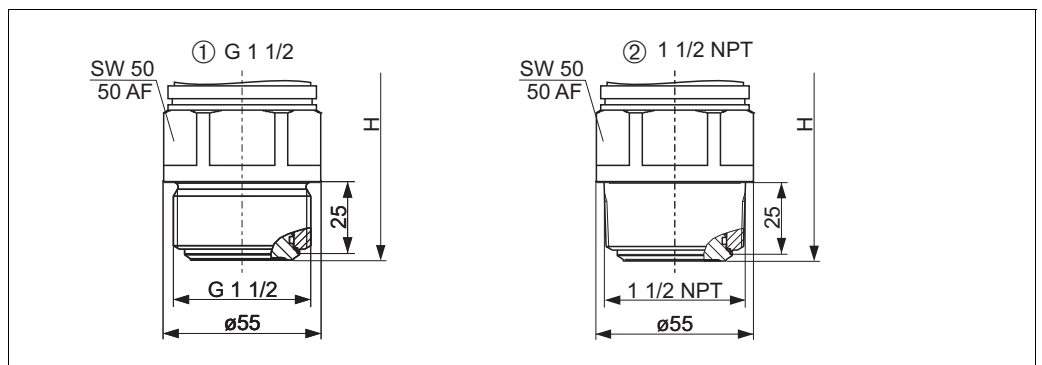

→ For the installation height, see the following table. For weight, see → 35.

- 1 Thread ISO 228 G 1 1/2 A;
Material version GGJ: AISI 316L/1.4435, version GGC: Alloy C276/2.4819
- 2 Thread ANSI 1 1/2 MNPT;
Material version RGJ: AISI 316L/1.4435

Installation height H, devices with a thread

F31 housing	F15 housing
156 mm (6.14 in)	148 mm (5.83 in)

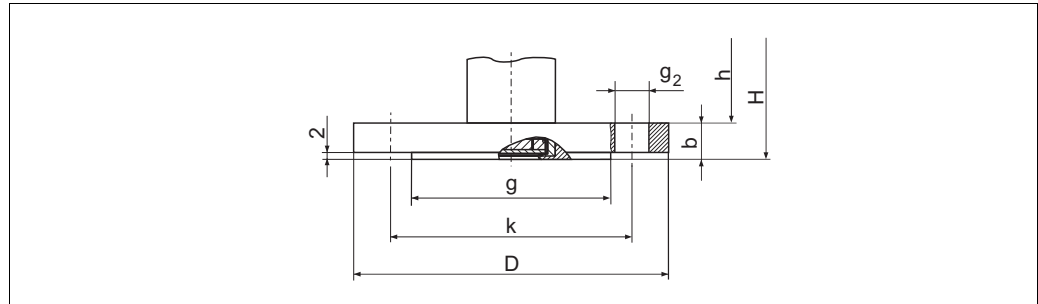
EN/DIN flanges, connection dimensions as per EN 1092-1/DIN 2527

P01-FMB70xxx-06-09-xx-xx-002

Flange with raised face

H : device height = height of device without flange h + flange thickness b
 Height H , see → 28.

Version	Flange ¹⁾								Boltholes			Flange weight ⁴⁾
	Material ²⁾	Nominal diameter	Nominal pressure	Shape ³⁾	Diameter	Thick-ness	Diameter of raised face	Height of raised face	Quantity	Diameter	Hole circle	
					D [mm]	b [mm]	g [mm]	f [mm]		g ₂ [mm]	k [mm]	
CEJ	AISI 316L	DN 40	PN 10/16	B1 (C)	150	18	88	2	4	18	110	2.6
CFJ	AISI 316L	DN 50	PN 10/16	B1 (C)	165	18	102	2	4	18	125	3.3
CGJ	AISI 316L	DN 80	PN 10/16	B1 (C)	200	20	138	2	8	18	160	5.1
CHJ	AISI 316L	DN 100	PN 10/16	B1 (C)	220	20	158	2	8	18	180	6.3

1) The roughness of the surface in contact with the medium, including the sealing surface of the flanges, is R_a 0.8 μm (31,5 μin). Lower surface roughness available on request.

2) AISI 316L

3) Designation as per DIN 2526 in brackets

4) Weight incl. pipe and measuring cell, housing weight, see → 35

ANSI flanges, connection dimensions as per ANSI B 16.5, raised face RF

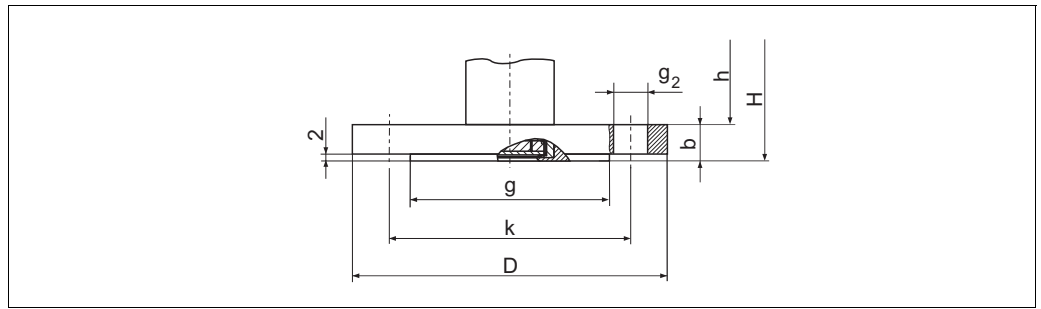

P01-FMB70xxx-06-09-xx-xx-002

Flange with raised face

H: device height = height of device without flange h + flange thickness b

Height H, see → 28.

Version	Flange ¹⁾							Boltholes			Flange weight ³⁾
	Material ²⁾	Nominal diameter	Class	Dia- meter D	Thick- ness b	Diameter of raised face g	Height of raised face f	Quant- ity	Diameter g ₂	Hole circle k	
		[in]	[lb./sq in]	[in] [mm]	[in] [mm]	[in] [mm]	[in] [mm]		[in] [mm]	[in] [mm]	[kg]
AEJ Not FMB51/52	AISI 316/ 316L	1 1/2	150	5 127	0.69 17.5	2.88 73.2	0.06 1.6	4	0.62 15.7	3.88 98.6	2.1
AFJ	AISI 316/ 316L	2	150	6 152.4	0.75 19.1	3.62 91.9	0.06 1.6	4	0.75 19.1	4.75 120.7	3.0
AGJ	AISI 316/ 316L	3	150	7.5 190.5	0.94 23.9	5 127	0.06 1.6	4	0.75 19.1	6 152.4	5.7
AHJ	AISI 316/ 316L	4	150	9 228.6	0.94 23.9	6.19 157.2	0.06 1.6	8	0.75 19.1	7.5 190.5	7.8

- 1) The roughness of the surface in contact with the medium, including the sealing surface of the flanges, is R_a 0.8 μm (31,5 μin). Lower surface roughness available on request.
- 2) Combination of AISI 316 for required pressure resistance and AISI 316L for required chemical resistance (dual rated)
- 3) Weight incl. pipe and measuring cell, housing weight, see → 35

JIS flanges, connection dimensions as per JIS B 2220 BL, raised face RF

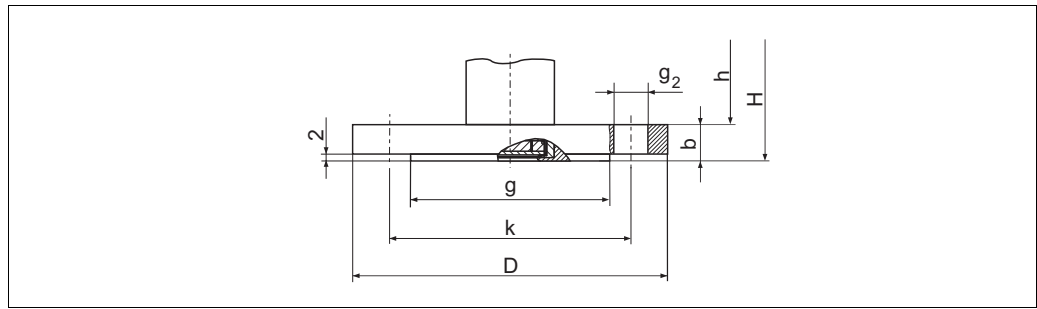

P01-FMB70xxx-06-09-xx-xx-002

Flange with raised face

H: device height = height of device without flange + flange thickness b

Height H, see → 28.

Version	Flange ¹⁾							Boltholes			Flange weight ²⁾
	Material	Nominal diameter	Nominal pressure	Diameter	Thickness	Diameter of raised face	Height of raised face	Quantity	Diameter	Hole circle	
				D [mm]	b [mm]	g [mm]	f [mm]		g ₂ [mm]	k [mm]	
KEJ	AISI 316L	40 A	10 K	140	16	81	2	4	19	105	2.1
KFJ	AISI 316L	50 A	10 K	155	16	96	2	4	19	120	2.5
KGJ	AISI 316L	80 A	10 K	185	18	126	2	8	19	150	3.8
KHJ	AISI 316L	100 A	10 K	210	18	151	2	8	19	175	4.9

1) The roughness of the surface in contact with the medium, including the sealing surface of the flanges (all standards), is R_a 0.8 μm (31,5 μin). Lower surface roughness available on request.

2) Weight incl. pipe and measuring cell, housing weight, see → 35

Installation height H, devices with flange

F31 housing	F15 housing
165 mm (6.5 in)	157 mm (6.18 in)

Universal process adapter

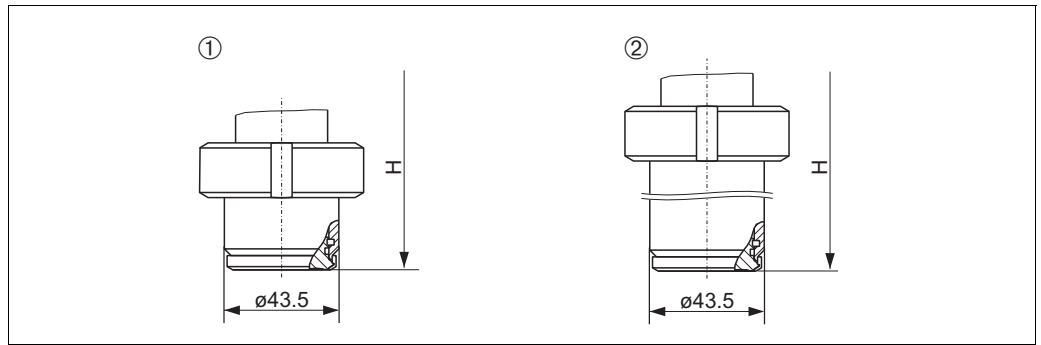

P01-FMB70xxx-06-09-xx-xx-003

Material: AISI 316L/1.4435;

Surface roughness of the surfaces in contact with the medium $R_a \leq 0.8 \mu\text{m}$ (6,18 in) as standard. Lower surface roughness available on request.

- 1 Version UPJ: universal process adapter incl. silicone molded seal, EHEDG, 3A
Version UNJ: universal process adapter incl. EPDM molded seal, EHEDG, 3A
- 2 Version UQJ: universal process adapter, 6 inch extension including silicone molded seal, EHEDG, 3A
Version UOJ: universal process adapter, 6 inch extension including EPDM molded seal, EHEDG, 3A

Installation height H, devices with universal process adapter

	F31 housing	F15 housing
Universal process adapter	196 mm (7.72 in)	189 mm (7.44 in)
Universal process adapter with 6 inch extension	307 mm (12.1 in)	299 mm (11.8 in)

Anderson process adapter

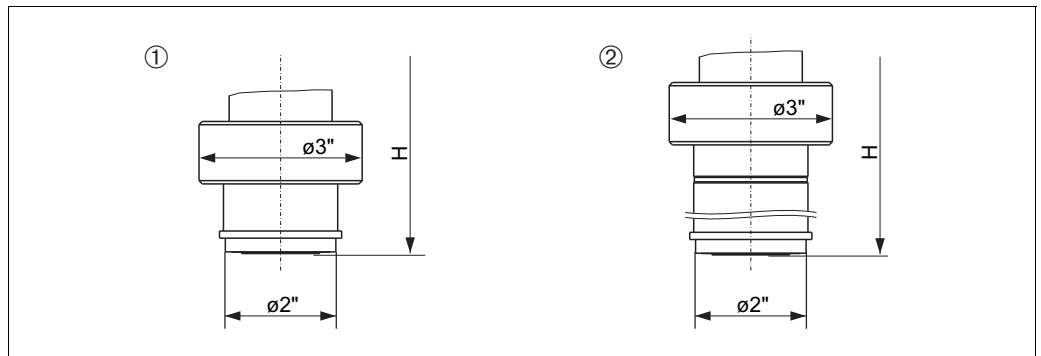

P01-FMBX0xxx-06-09-xx-xx-000

Material: AISI 316L/1.4435;

Surface roughness of the surfaces in contact with the medium $R_a \leq 0.8 \mu\text{m}$ (31,5 μin) as standard. Lower surface roughness available on request.

- 1 Version USJ: Anderson process adapter short 2-3/16", incl. silicone molded seal, 3A
- 2 Version UTJ: Anderson process adapter long 6-1/2", incl. silicone molded seal, 3A

Installation height H, devices with Anderson process adapter

	F31 housing	F15 housing
Anderson short	204 mm (8.03 in)	196 mm (7.72 in)
Anderson long	314 mm (12.4 in)	306 mm (12 in)

Hygienic connections

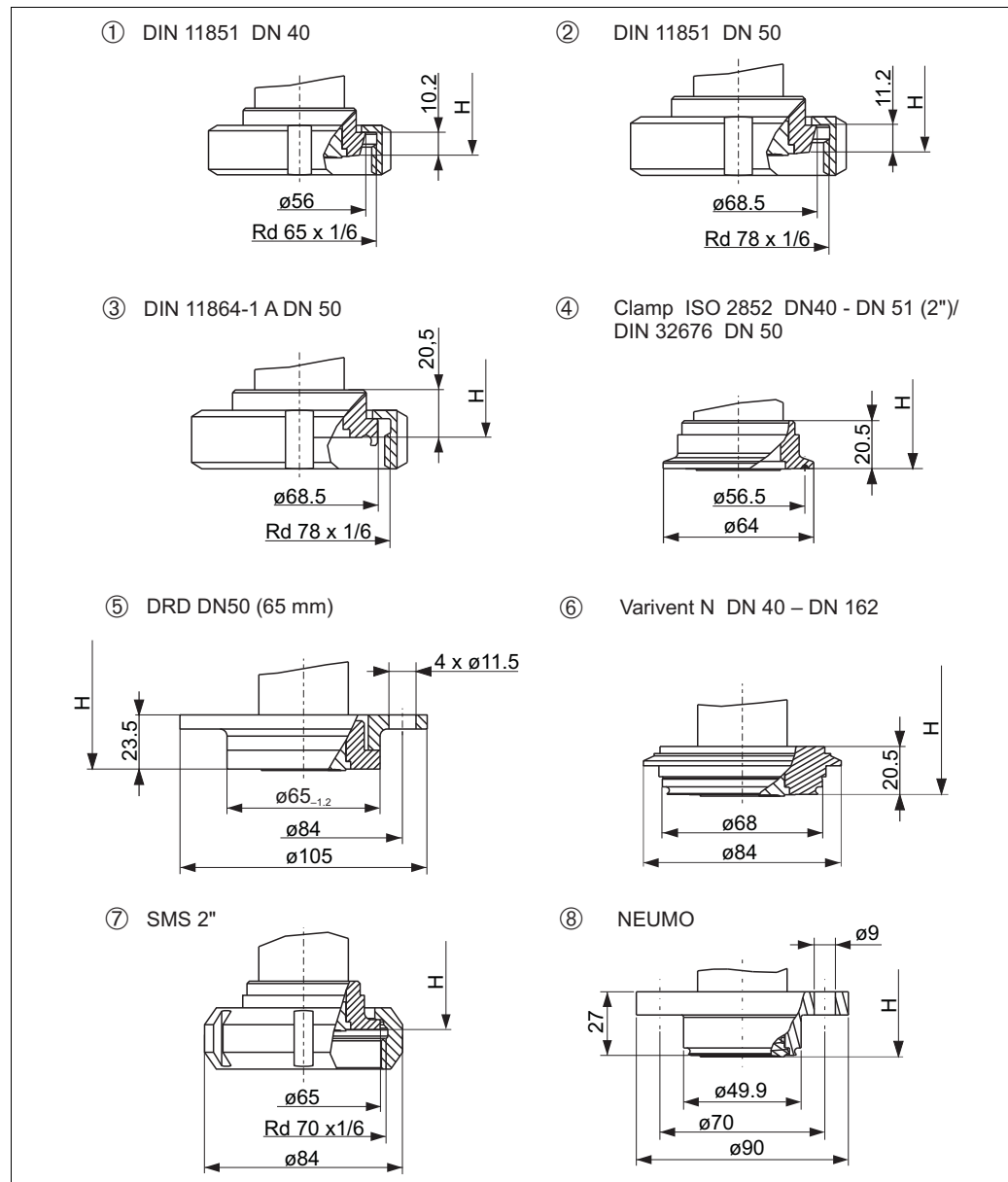

P01-FMB5xxxx-06-xx-xx-xx-001

Hygienic connections, material AISI 316L/1.4435

Surface roughness of the surfaces in contact with the medium $R_a \leq 0.8 \mu\text{m}$ ($31,5 \mu\text{in}$) as standard. Lower surface roughness available on request. For weight, see → 35.

- 1 Version MZJ: DIN 11851 DN 40 PN 25, EHEDG¹⁾, 3A²⁾
- 2 Version MRJ: DIN 11851 DN 50 PN 25, EHEDG¹⁾, 3A²⁾
- 3 Version NDJ: DIN 11864-1 A DN50 PN16 pipe DIN11866-A, threaded connection, 316L, EHEDG, 3A
- 4 Version TDJ: Tri-Clamp ISO 2852 DN 40 – DN 51 (2"), DIN 32676 DN 50, EHEDG¹⁾, 3A
- 5 Version TIJ: DRD DN50 (65 mm) PN 25, 316L
- 6 Version TRJ: Varivent Typ N for pipes 40 – 162, PN 40, EHEDG, 3A
- 7 Version TXJ: SMS 2", PN25, EHEDG¹⁾, 3A²⁾
- 8 Version S4J: NEUMO, D50, PN16, 316L, 3A

Installation height H, devices with Tri-Clamp or hygienic connection

F31 housing	F15 housing
185 mm (7.28 in)	178 mm (7.01 in)

- 1) Suitable fittings and seals must be used for hygienic design in accordance with EHEDG specifications.
- 2) Suitable fittings and seals must be used for hygienic design in accordance with 3A specifications.

Process connections FMB51
(rod version)

Threaded connection ISO 228 and NPT

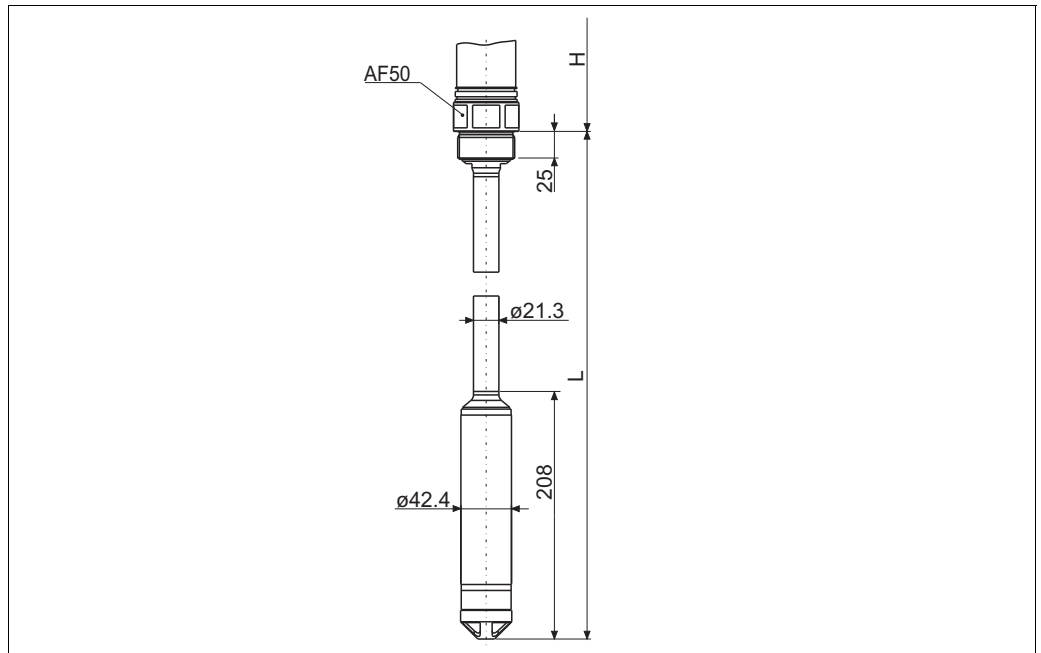

P01-FMB51-xxxx-06-xx-xx-en-000

Rod version with thread G 1 1/2 or 1 1/2 NPT

L Probe length = 0.4 to 4 m (1.3 ft to 13 ft)

H For installation height H → 26

→ For dimensions of process connections → 25 ff.

EN/DIN, ANSI and JIS flanges

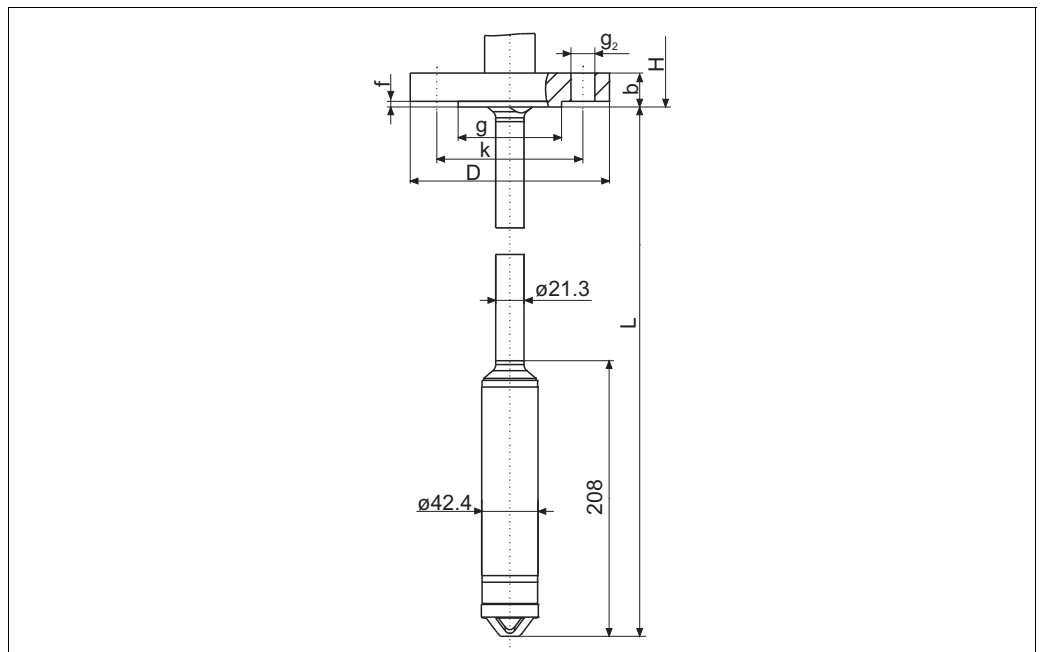

P01-FMB51-xxxx-06-xx-xx-en-001

Rod version with flange

L Probe length = 0.4 to 4 m (1.3 ft to 13 ft)

H For installation height H → 28

→ For dimensions of process connections → 25 ff.

Process connections FMB52
(cable version)

Threaded connection ISO 228 and NPT

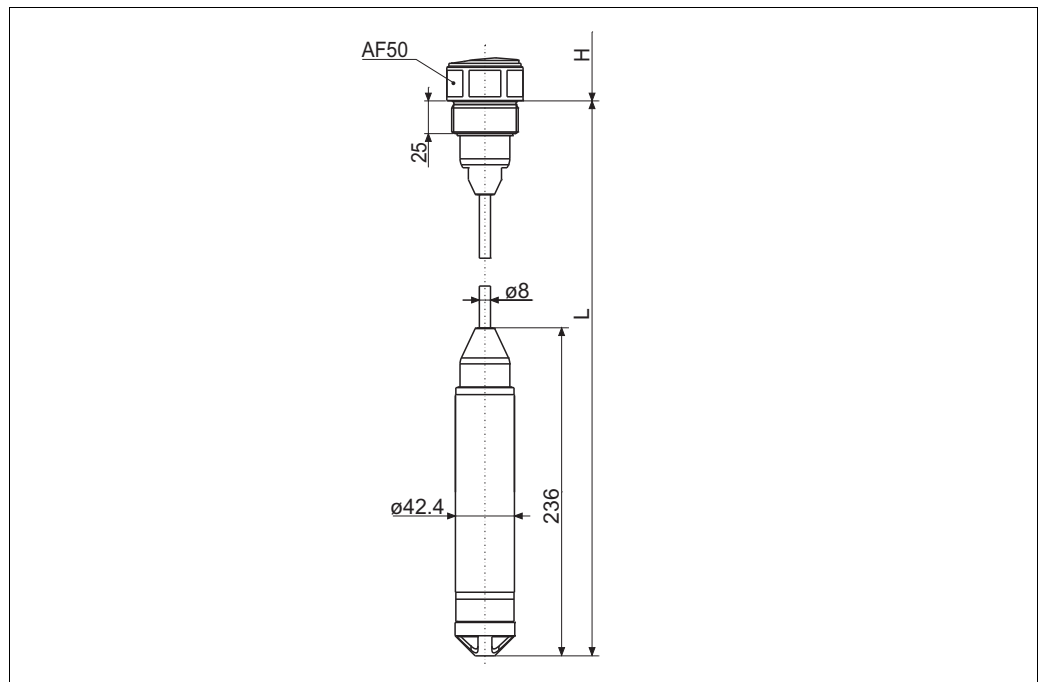

P01-FMB52xxx-06-xx-xx-en-000

Cable version with thread G 1 1/2 and 1 1/2 NPT

L Probe length = 0.5 to 400 m (1.6 to 1312 ft)

H For installation height $H \rightarrow$ 26

\rightarrow For dimensions of process connections \rightarrow 25 ff.

EN/DIN, ANSI and JIS flanges

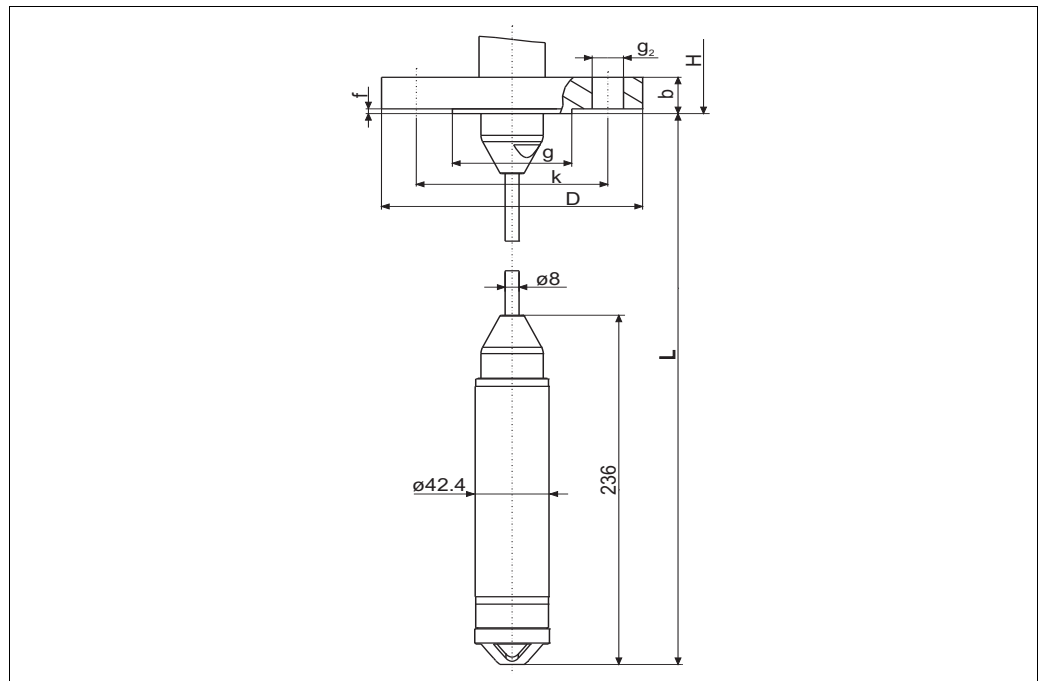

P01-FMB52xxx-06-xx-xx-xx-001

Cable version with flange

L Probe length = 0.5 to 400 m (1.6 to 1312 ft)

H For installation height $H \rightarrow$ 28

\rightarrow For dimensions of process connections \rightarrow 25 ff.

Dimensions of Deltapilot M FMB53 (suspension clamp and mounting bracket)

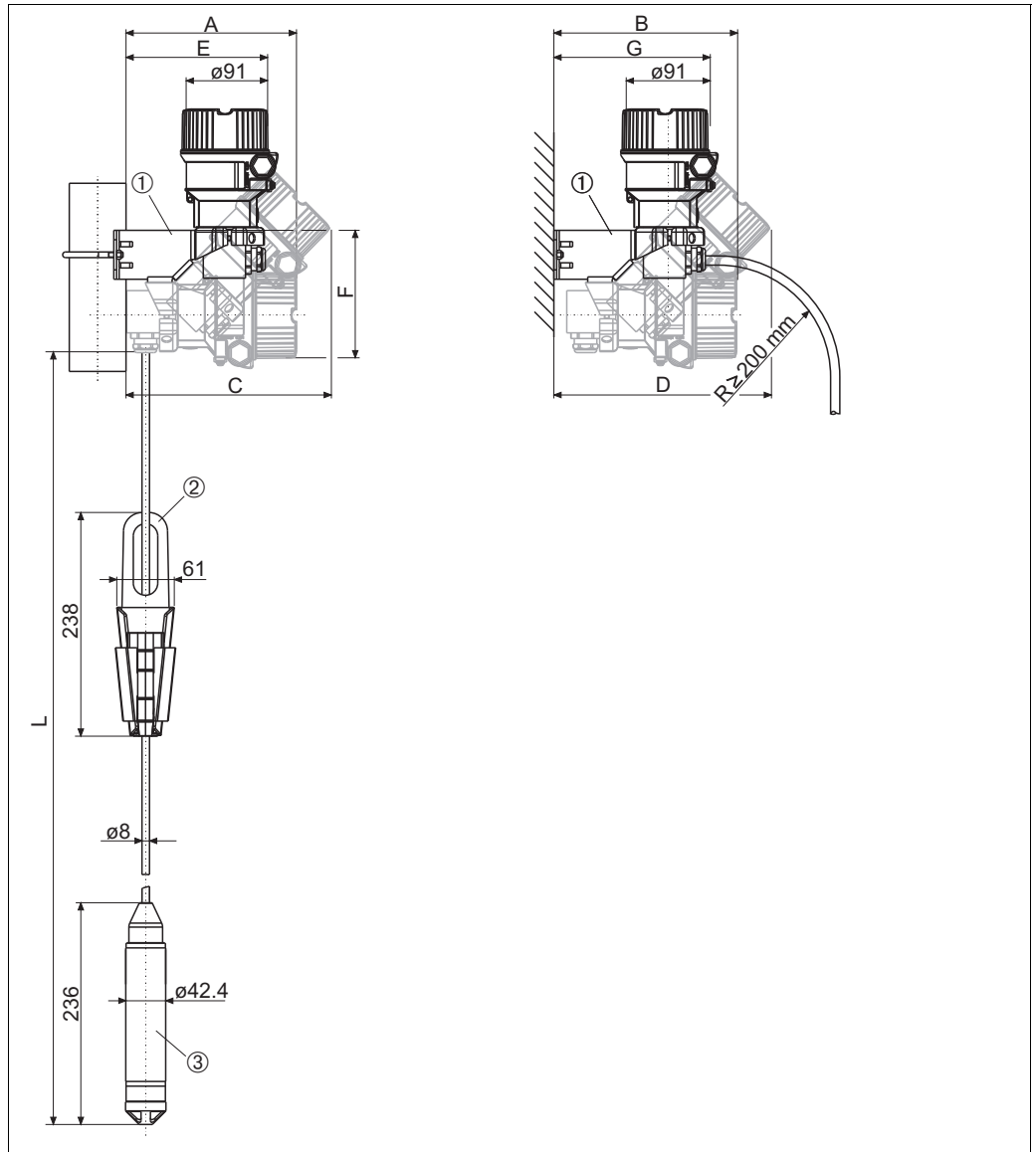

P01-FMB53xxxx-06-xx-xx-xx-000

FMB53 with suspension clamp and mounting bracket

- 1 Mounting bracket for pipe and wall mounting (for pipes with 2" diameter)
- 2 Suspension clamp
- 3 Measuring cell tube
- L Probe length = 0.5 to 400 m (1.6 to 1312 ft)

Dimensions (in mm)

	Pipe mounting				Wall mounting			
	A [mm (in)]		C [mm (in)]		B [mm (in)]		D [mm (in)]	
	Cover flat	Cover high	Cover flat	Cover high	Cover flat	Cover high	Cover flat	Cover high
F15 housing	154.7 (6.09)	173.7 (6.84)	197.1 (7.76)	210.6 (8.29)	167.7 (6.6)	186.7 (7.35)	210.1 (8.27)	223.6 (8.8)
F31 housing	167 (6.57)	181.3 (7.14)	211.8 (8.34)	221.7 (8.73)	180 (7.09)	194.3 (7.65)	224.8 (8.85)	234.7 (9.24)

	E [mm (in)]	F [mm (in)]	G [mm (in)]
F15 housing	146 (5.75)	127 (5)	159 (6.26)
F31 housing	156.2 (6.15)	137.2 (5.4)	169.2 (6.66)

Wall and pipe mounting with "Separate housing" version

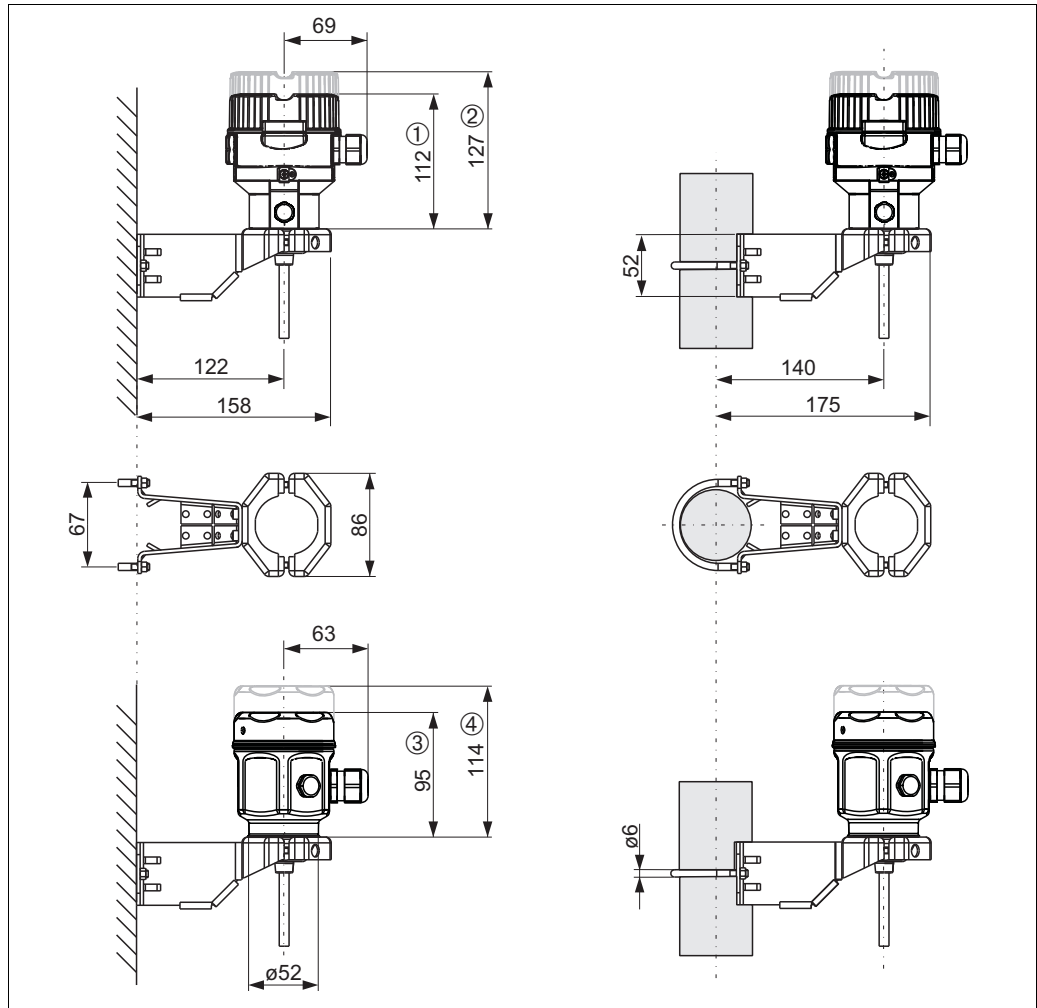

P01-xMx5xxxx-06-xx-xx-xx-004

F31 housing dimensions. Housing weight → 35. ① Cover without viewing window. ② Cover with viewing window.

F15 housing dimensions. Housing weight → 35. ③ Cover without viewing window. ④ Cover with viewing window.

Reduction in installation height

If the separate housing is used, the mounting height of the process connection is reduced compared to the dimensions of the standard version (see graphic).

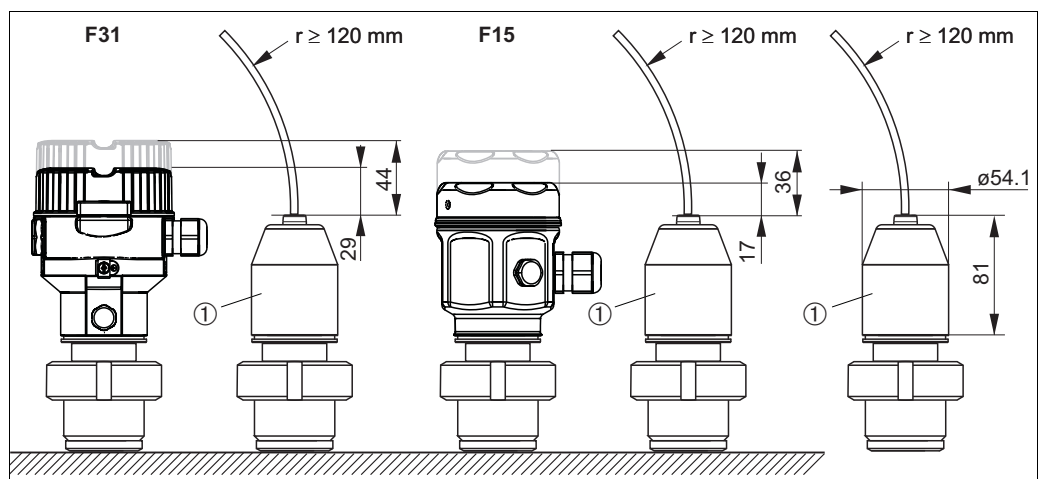

P01-xMx5xxxx-06-xx-xx-xx-000

1 Process connection adapter.

A minimum bending radius (r) of 120 mm (4,72 in) must be observed for the cable.

Example for a "Separate housing" version

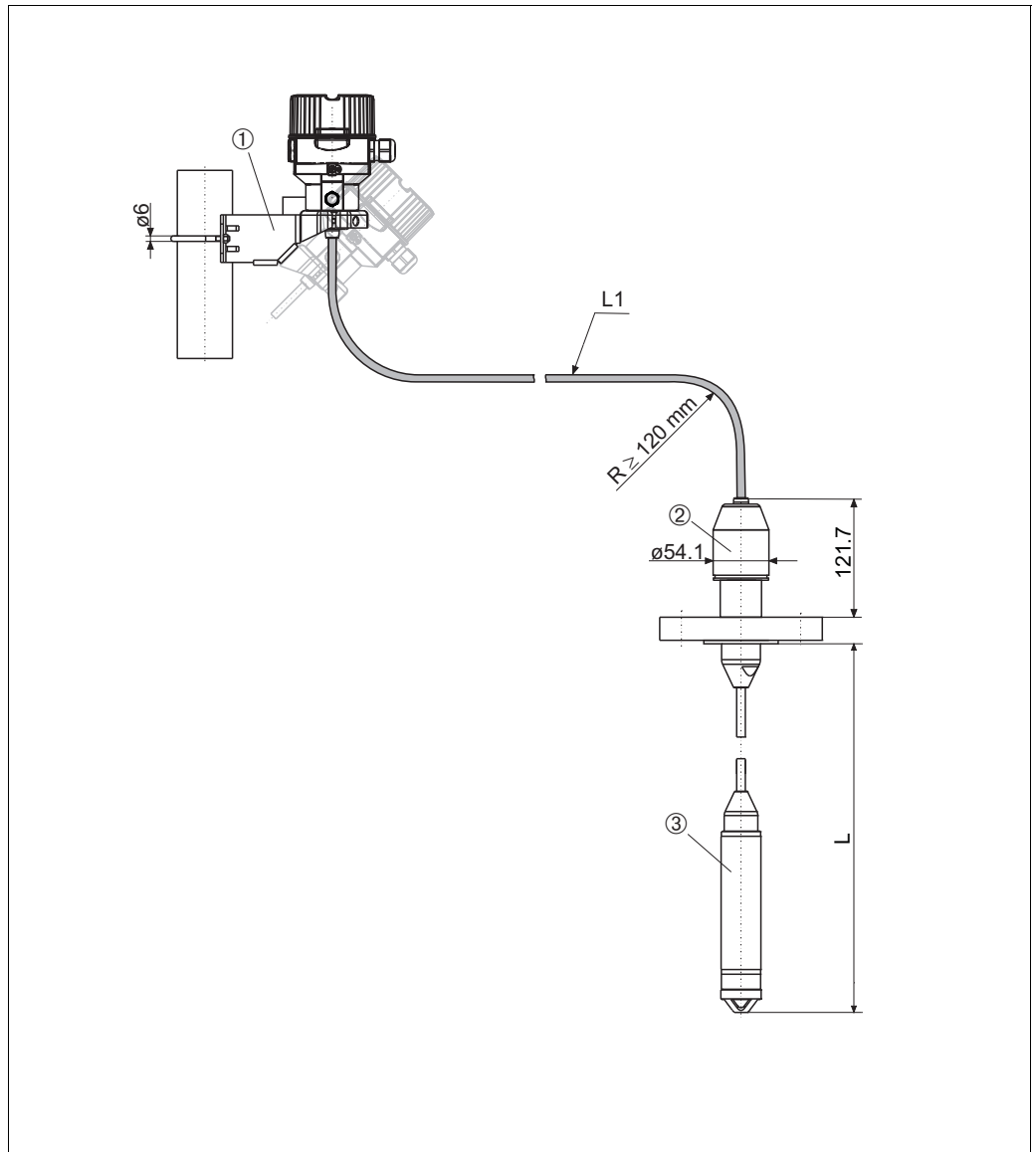

Connecting cable with process connection adapter and mounting bracket, here shown with an FMB52

- 1 Mounting bracket for pipe and wall mounting (for pipes with 2" diameter)
- 2 Process connection adapter
- 3 Measuring cell tube
- L1 PE cable = 2 m (6.6 ft), 5 m (16 ft) or 10 m (33 ft)
FEP cable = 5 m (16 ft)
- L Probe length = 0.5 to 400 m (1.6 to 1312 ft)

Note!

For FMB50, FMB51, FMB52, order the separate housing via feature 600 "Separate housing" or subsequently as an accessory.

Weight

Housing

	F31 housing	F15 housing
	Aluminum	AISI 316L
With electronic insert and local display	1.1 kg (2.43 lbs)	0.8 kg (1.76 lbs)

Separate housing

Designation	Weight
Separate housing for FMB50	Weight of housing (→ 35) + 0.5 kg (1.10 lbs).
Separate housing for FMB51 and FMB52	Weight of housing (→ 35) + 0.65 kg (1.43 lbs).
Process connection adapter	0.4 kg (0.88 lbs)
Mounting bracket	0.2 kg (0.44 lbs)
Pipe bend incl. cable entry	0.65 kg (1.43 lbs)
PE cable 2 m (6,6 ft)	0.16 kg (0.35 lbs)
PE cable 5 m (16 ft)	0.32 kg (0.71 lbs)
PE cable 10 m (33 ft)	0.59 kg (1.30 lbs)
FEP cable 5 m (16 ft)	0.62 kg (1.37 lbs)

Note!

Total weight = weight of separate housing + weight cable + weight mounting bracket +
 Pipe bend + weight process connection adapter + (see following chapters)
 Process connections FMB50 or Process connection and pipe FMB51 or Process connection and cable FMB52

Process connections FMB50

Process connection incl. sensor	Weight
DIN 11851 DN 40	0.7 kg (1.54 lbs)
DIN 11851 DN 50	0.9 kg (1.98 lbs)
Tri-Clamp ISO 2852 DN 40 – DN 51 (2")/DIN 32676 DN 50	0.7 kg (1.54 lbs)
DRD DN50 (65 mm)	1.1 kg (2.43 lbs)
Varivent Typ N for pipes DN 40 – DN 162	1.0 kg (2.21 lbs)
SMS 2"	0.7 kg (1.54 lbs)
NEUMO D50	1.1 kg (2.43 lbs)
Universal process adapter	0.8 kg (1.76 lbs)
Universal process adapter with 6 inch extended diaphragm seal	1.7 kg (3.75 lbs)
Thread ISO228 G1 1/2A, AISI316L / 1.4435	0.8 kg (1.76 lbs)
Thread ISO228 G1 1/2A, Alloy C276 / 2.4819	0.8 kg (1.76 lbs)
Thread ANSI 1 1/2 MNPT, AISI316L / 1.4435	0.8 kg (1.76 lbs)
Flange connection, incl. sensor, without a flange	0.45 kg (0.99 lbs)

Note!

Total weight of device = weight of housing (→ 35) + weight of process connection FMB50

Process connection and pipe FMB51

Process connection incl. sensor	Weight
Pipe incl. cable	0.77 kg/m (1.70 lbs/3.3 ft)
Threaded connection incl. measuring cell tube and sensor	1.65 kg (3.64 lbs)
Flange connection incl. measuring cell tube and sensor, without a flange	1.3 kg (2.87 lbs)

Note!

- Total weight of device with threaded connection = weight of housing (→ 35) + weight of pipe incl. cable x length + weight of process connection FMB51
- Total weight of device with flange connection = weight of housing (→ 35) + weight of pipe incl. cable x length + weight of process connection FMB51

Process connection and cable FMB52

Process connection incl. sensor	Weight
PE cable	0.13 kg/m (0.28 lbs/3.3 ft)
FEP cable	0.18 kg/m (0.40 lbs/3.3 ft)
Threaded connection incl. measuring cell tube and sensor	1.65 kg (3.64 lbs)
Flange connection incl. measuring cell tube and sensor, without a flange	1.3 kg (2.87 lbs)

Note!

- Total weight of device with threaded connection = weight of housing (→ 35) + weight of cable x length + weight of process connection FMB52
- Total weight of device with flange connection = weight of housing (→ 35) + weight of pipe incl. cable x length + weight of process connection FMB52 + weight of flange (→ 26 ff)

Process connection FMB53 – secured with suspension clamp and mounting bracket

Process connection incl. sensor	Weight
PE cable	0.13 kg/m (0.28 lbs/3.3 ft)
FEP cable	0.18 kg/m (0.40 lbs/3.3 ft)
Mounting bracket	0.2 kg (0.44 lbs)
Pipe bend incl. cable entry	0.65 kg (1.43 lbs)
Suspension clamp	0.4 kg (0.88 lbs)
Measuring cell tube incl. sensor	1.0 kg (2.21 lbs)

Note!

Total weight of device = weight of housing (→ 35) + weight of cable x length + weight of mounting bracket + weight of pipe bend + weight of suspension clamp + weight of measuring cell tube

Material**F31 housing:**

- F31 housing, optionally:
 - Die-cast aluminum with protective powder-coating on polyester base: RAL 5012 (blue), cover: RAL 7035 (gray)
- Sight glass: mineral glass
- Cable gland M20 x 1.5: polyamide (PA) or CuZn nickel-plated
- Pressure compensation filter: PA6 GF10
- Cable entry blind plug:
 - G 1/2": PBT-GF30 FR, for Dust Ex, Ex d, FM XP and CSA XP: AISI 316L (1.4435)
 - NPT 1/2": PBT-GF30 FR, for Dust Ex, Ex d, FM XP and CSA XP: AISI 316L (1.4435)
- Seals:
 - Cable gland and blind plug: EPDM
 - Pressure compensation filter O-ring: silicone (VMQ)
 - Cover: EPDM
 - Sight glass: silicone (VMQ)
- Nameplates: plastic

F15 housing:

- Housing and cover: stainless steel AISI 316L (1.4404)
- Sight glass:
 - Version for non-hazardous areas, ATEX Ex ia, NEPSI Zone 0/1 Ex ia, IECEx Zone 0/1 Ex ia, FM NI, FM IS, CSA IS: polycarbonate (PC)
 - ATEX 1/2 D, ATEX 1/3 D, ATEX 1 GD, ATEX 1/2 GD, ATEX 3 G, FM DIP, CSA Dust Ex: mineral glass
- Cable gland M20 x 1.5: polyamide PA, for Dust-Ex: CuZn nickel-plated
- Pressure compensation filter: PA6 GF10
- Blind plug: PBT-GF30 FR, for Dust Ex: AISI 316L (1.4435)
- Seals:
 - Cable gland and blind plug: NBR
 - Pressure compensation filter O-ring: silicone (VMQ)
 - Cover: silicone with PTFE coating
 - Sight glass: silicone (VMQ)

- Nameplates: lasered

DIN/EN flanges

Endress+Hauser supplies DIN/EN flanges made of stainless steel AISI 316L as per material numbers 1.4435 or 1.4404. With regard to their stability-temperature property, the materials 1.4435 and 1.4404 are grouped together under 13EO in EN 1092-1 Tab. 18. The chemical composition of the two materials can be identical.

Seals

- For universal process adapter 44
 - mm: silicone molded seal FDA 21CFR177.2600/USP Class VI.
 - EPDM molded seal, 3A, EHEDG.
- FKM
- EPDM
- Kalrez 6375

Separate housing

- Process connection adapter: AISI 316L (1.4404)
- Housing adapter:
 - FMB50, FMB51, FMB52: AISI 316L (1.4404)
 - FMB53: AISI 304 (1.4301)
 - Cable gland: CuZn nickel-plated
 - Sealing insert: TPE-V
 - O-ring: NBR
- Cable:
 - PE cable:
 - Abrasion-proof cable with strain-relief Dynema members; shielded using aluminum-coated foil; insulated with polyethylene (PE-LD), black; copper wires, twisted, UV-resistant
 - FEP cable:
 - Abrasion-proof cable; shielded using galvanized steel wire mesh; insulated with fluorinated ethylene propylene (FEP), black; copper wires, twisted, UV-resistant
 - O-ring: FKM, EPDM
 - Cable socket: AISI 316L (1.4404)
 - Bolts: A2

TSE Certificate of Suitability

The following applies to all process wetted device components:

- They do not contain any materials derived from animals.
- No auxiliaries or operating materials derived from animals are used in production or processing.

Note!

The wetted device components are listed in the "Mechanical construction" (→ 25 ff) and "Ordering information" (→ 43 ff) sections.

Miscellaneous:

- Mounting accessories: mounting bracket AISI 304 (1.4301)
 - Process isolating diaphragm: Alloy C276 (2.4819), Ø 35.8 mm (1.41 in)
 - Filling oil
 - Synthetic oil polyalphaolefin FDA 21 CFR 172.882
 - Inert oil
- For process connections and filling oils, see ordering information, → 43 ff.

Human interface

Local operation

Local display (optional)

A 4-line liquid crystal display (LCD) is used for display and operation. The local display shows measured values, dialog texts as well as fault and notice messages in plain text, thereby supporting the user at every stage of operation. The liquid crystal display of the device can be turned in 90° stages. Depending on the orientation of the device, this makes it easy to operate the device and read the measured values.

Functions:

- 8-digit measured value display including sign and decimal point, bar graph for 4 to 20 mA HART as current display
- Three keys for operation
- Simple and complete menu guidance as parameters are split into several levels and groups
- Each parameter is given a 3-digit ID number for easy navigation
- Possibility of configuring the display to suit individual requirements and preferences, such as language, alternating display, contrast setting, display of other measured values such as sensor temperature etc.
- Comprehensive diagnostic functions (fault and warning message etc.)

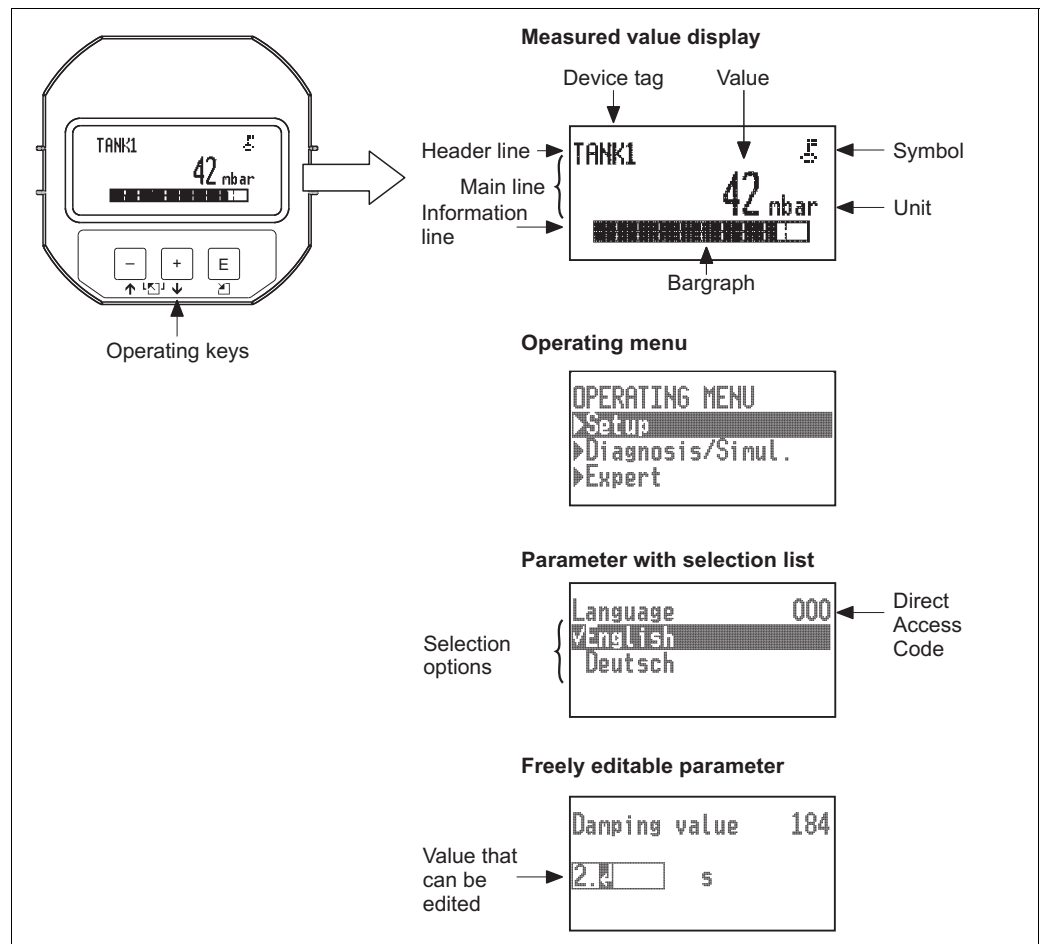

P01-Mxxxxxx-07-xx-xx-xx-002

Operating keys and elements located on the electronic insert

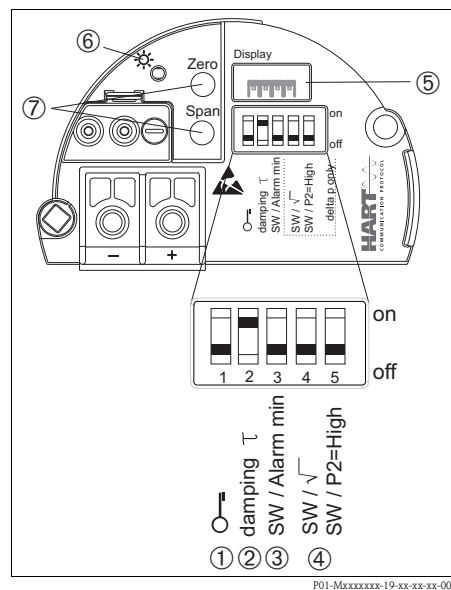

HART electronic insert

- 1 DIP switch for locking/unlocking parameters relevant to the measured value
- 2 DIP switch for switching damping on/off
- 3 DIP switch for alarm current SW / Alarm Min (3.6 mA)
- 4 DIP switch only for Deltabar M
- 5 Slot for optional local display
- 6 Green LED to indicate successful operation
- 7 Operating keys for lower range value (zero) and upper range value (span)

Functions of the local display and the operating keys and operating elements on the electronic insert

- Position adjustment (zero point correction)
- Setting lower range value and upper range value - reference pressure present at the device
- Device reset
- Locking and unlocking parameters relevant to the measured value
- Switching damping on and off
- Value acceptance indicated by the green LED (not visible if display attached)

Remote operation

All software parameters are accessible depending on the position of the write protection switch on the device.

HART

Remote operation via:

- Field Communicator 375 handheld terminal. Use the handheld terminal to set all parameters all along the bus cable via menu operation.
- Field Xpert. Field Xpert is an industrial PDA with integrated 3.5" touchscreen from Endress+Hauser based on Windows Mobile. It communicates via wireless with the optional VIATOR Bluetooth modem connected to a HART device point-to-point or wireless via WiFi and Endress+Hauser's Fieldgate FXA520. Field Xpert also works as a stand-alone device for asset management applications. For details refer to BA060S/00/EN.
- FieldCare. FieldCare is an Endress+Hauser asset management tool based on FDT technology. With FieldCare, you can configure all Endress+Hauser devices.
 - FieldCare supports the following functions:
 - Configuration of transmitters in offline and online mode
 - Loading and saving device data (upload/download)
 - Documentation of the measuring point
 - Connection options:
 - By means of the Commubox FXA191 for intrinsically safe HART communication with FieldCare via the RS232C interface of a computer. For details refer to TI237F/00/EN.
 - By means of the Commubox FXA195 for intrinsically safe HART communication with FieldCare via the USB port of a computer. For details refer to TI404F/00/EN.

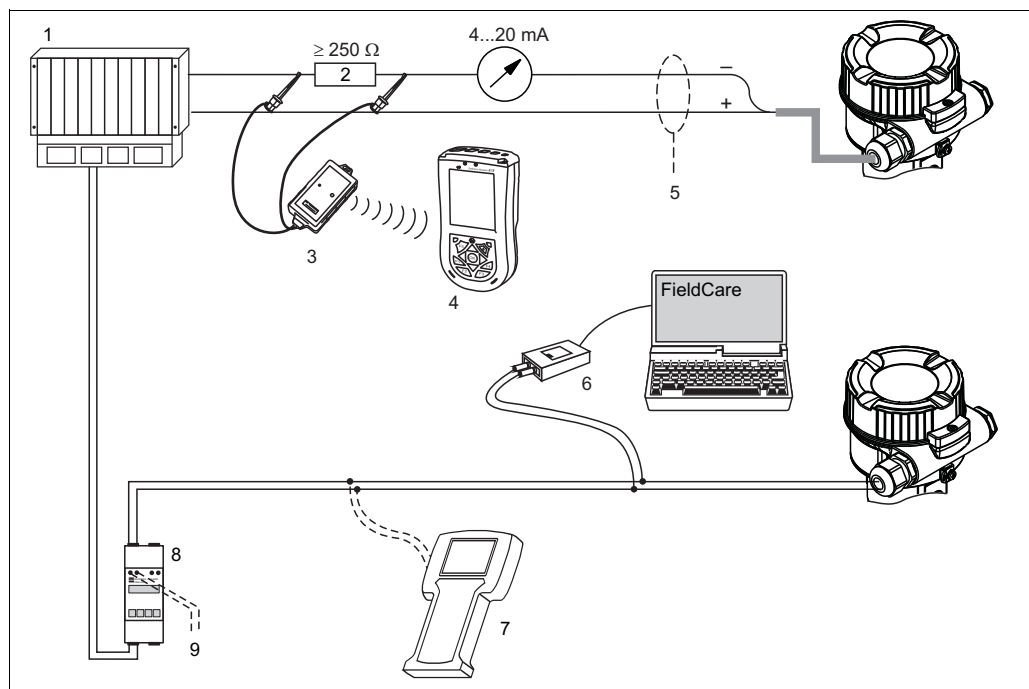

- 1 PLC
- 2 Resistor for HART communication
- 3 VIATOR Bluetooth Modem with connection cable
- 4 Field Xpert (Industrial PDA)
- 5 Screening
- 6 Commubox FXA191 (RS232), FXA195 (USB)
- 7 Handheld terminal DXR375/FC375
- 8 Transmitter power supply unit RMA422 or RN221N (with integrated communication resistor)
- 9 Connection for:
 - Commubox FXA191 (RS232), FXA195 (USB)
 - Handheld terminal DXR375/FC375

Note!

For further information please contact your local Endress+Hauser Sales Center.

Certificates and approvals

CE mark	The device meets the legal requirements of the relevant EC directives. Endress+Hauser confirms that the device has been successfully tested by applying the CE mark.
Ex approvals	<ul style="list-style-type: none"> ■ ATEX ■ FM ■ CSA ■ Also combinations of different approvals <p>All explosion protection data are given in separate documentation which is available upon request. The Ex documentation is supplied as standard with all devices approved for use in explosion hazardous areas. → 56 ff, "Safety Instructions" and "Installation/Control Drawings" sections.</p>
Suitability for hygienic processes	<p>The Deltapilot M is suitable for use in hygienic processes. Overview of permitted process connections from → 25. Many versions meet the requirements of 3A-Sanitary Standard No. 74 and are certified by the EHEDG (pending).</p> <p>Note! Gap-free connections can be cleaned without residue using the usual cleaning methods.</p> <div style="text-align: right;">  </div>
Standards and guidelines	<p>DIN EN 60770 (IEC 60770): Transmitters for use in industrial process control systems Part 1: Methods for inspection and routine testing</p> <p>DIN 16086: Electrical pressure measuring instruments, pressure sensors, pressure transmitters, pressure measuring instruments, concepts, specifications on data sheets</p> <p>EN 61326 series: EMC product family standard for electrical equipment for measurement, control and laboratory use.</p>
Pressure Equipment Directive (PED)	The Deltapilot M device corresponds to Article 3 (3) of the EC directive 97/23/EC (Pressure Equipment Directive) and has been designed and manufactured according to good engineering practice.
Drinking water approval	<ul style="list-style-type: none"> ■ KTW certificate ■ NSF 61 approval ■ ACS approval

Ordering information

FMB50

This overview does not mark options which are mutually exclusive.

10	Approval:	
	AA	For non-hazardous areas
	BA	ATEX II 1/2G Ex ia IIC T6
	BB	ATEX II 1/2D Ex t IIIC
	BD	ATEX II 3G Ex nA IIC T6
	BE	ATEX II 2G Ex ia IIC T6
	B1	ATEX II 1/2G Ex ia IIC T6 + ATEX II 1/2D, Ex iaD
	IA	IEC Ex ia IIC T6 Ga/Gb
	ID	IEC Ex t IIIC Da/Db
	IE	IEC Ex ic IIC T6 Gc
	I1	IEC Ex ia IIC T6 Ga/Gb+Ex ia IIIC Da/Db
	CA	CSA C/US IS Cl.I,II,III Div.1 Gr.A-G, CSA C/US IS Cl.I Div.2 Gr.A-D, Ex ia, C: Zone 0,1,2/US: Zone 0,1,2,20,21,22
	CC	CSA C/US Cl.II, III Div.1 Gr.E-G, US: Zone 21,22
	CD	CSA General Purpose
	FA	FM IS Cl.I,II,III Div.1 Gr.A-G, AEx ia, FM NI Cl.I Div.2 Gr.A-D FM IS: zone 0,1,2,20,21,22/FM NI: zone 2
	FC	FM DIP Cl.II, III Div.1 Gr.E-G, zone 21,22
	FD	FM NI Cl.I Div.2 Gr.A-D
	99	Special version
20	Output:	
	2	4-20mA HART
	9	Special version
30	Display, operation	
	1	LCD, push buttons
	2	W/o LCD, push buttons
	9	Special version
40	Housing:	
	I	F31 aluminum
	J	F31 aluminum, glass window
	Q	F15 stainless steel Hygiene
	R	F15 stainless steel Hygiene, glass, window
	S	F15 stainless steel Hygiene, plastic, window
	Y	Special version
50	Electrical connection:	
	A	Gland M20, IP66/68 NEMA4X/6P
	C	Thread G1/2, IP66/68 NEMA4X/6P
	D	Thread NPT1/2, IP66/68 NEMA4X/6P
	I	Connector M12, IP66/68, NEMA4X/6P
	M	Connector 7/8", IP66/68, NEMA4X/6P
	P	Connector Han7D, 90deg, IP65
	S	Cable 5m, IP66/68 NEMA4X/6P + pressure compensation via cable
	V	Valve connector ISO4400 M16, IP64
	Y	Special version
70	Sensor range:	
	1C	100mbar/10kPa/1.5psi relative, 1mH2O/3ftH2O/40inH2O Overload: 4bar/400kPa/60psi
	1F	400mbar/40kPa/6psi relative, 4mH2O/13ftH2O/160inH2O Overload: 8bar/800kPa/120psi
	1H	1.2bar/120kPa/18psi relative, 12mH2O/40ftH2O/480inH2O Overload: 24bar/2.4MPa/350psi
	1M	4bar/400kPa/60psi relative, 40mH2O/133ftH2O/1600inH2O Overload: 24bar/2.4MPa/350psi
	1P	10bar/1MPa/150psi relative, 100mH2O/333ftH2O/4000inH2O Overload: 40bar/4MPa/600psi
	99	Special version
80	Reference accuracy:	
	D	Platinum
	G	Standard
	Y	Special version

FMB50 (continued)

90		Calibration; Unit:
A		Sensor range; %
B		Sensor range; mbar/bar
C		Sensor range; kPa/MPa
D		Sensor range; mm/mH ₂ O
E		Sensor range; inH ₂ O/ftH ₂ O
F		Sensor range; psi
J		Customized pressure; see additional spec.
K		Customized level; see additional spec.
Y		Special version
110		Process connection:
Threaded connection		
GCC		Thread ISO228 G1-1/2, AlloyC
GGJ		Thread ISO228 G1-1/2, 316L
RGJ		Thread ANSI MNPT1-1/2, 316L
ANSI flanges		
AEJ		1-1/2" 150lbs RF, 316/316L, flange ANSI B16.5
AFJ		2" 150lbs RF, 316/316L, flange ANSI B16.5
AGJ		3" 150lbs RF, 316/316L, flange ANSI B16.5
AHJ		4" 150lbs RF, 316/316L, flange ANSI B16.5
EN flanges		
CEJ		DN40 PN10/16 B1, 316L, flange EN1092-1
CFJ		DN50 PN10/16 B1, 316L, flange EN1092-1
CGJ		DN80 PN10/16 B1, 316L, flange EN1092-1
CHJ		DN100 PN10/16 B1, 316L, flange EN1092-1
JIS flanges		
KEJ		10K 40 RF, 316L, flange JIS B2220
KFJ		10K 50 RF, 316L, flange JIS B2220
KGJ		10K 80 RF, 316L, flange JIS B2220
KHJ		10K 100 RF, 316L, flange JIS B2220
Hygienic connections		
MRJ		DIN11851 DN50 PN25 cap-nut, 316L, EHEDG ²⁾ , 3A ¹⁾
MZJ		DIN11851 DN40 PN25 cap-nut, 316L, EHEDG ²⁾ , 3A ¹⁾
NDJ		DIN11864-1 A DN50 PN16 tube DIN11866-A, threaded connection, 316L, EHEDG, 3A
S4J		NEUMO BioControl D50 PN16, 316L, 3A
TXJ		SMS 2" PN25, 316L, EHEDG ²⁾ , 3A ¹⁾
TIJ		DRD DN50 65mm PN25, 316L
TRJ		Varivent N pipe DN40-162 PN40, 316L, EHEDG, 3A
UNJ		Universal adapter 316L, EPDM molded seal, 3A, EHEDG
UOJ		Universal adapter 316L, 6" ext., EPDM molded seal, 3A, EHEDG
UPJ		Universal adapter 44mm 316L, 3A, EHEDG, incl. silicone molded seal
UQJ		Universal adapter 44mm 316L, ext. 6", 3A, EHEDG, incl. silicone molded seal
USJ		Anderson short 2-3/16", 316L, 3A, incl. silicone seal
UTJ		Anderson long 6-1/2", 316L, 3A, incl. silicone seal
Clamp connections		
TDJ		Tri-Clamp ISO2852 DN40-51 (2"), 316L, DIN32676 DN50, EHEDG ²⁾ , 3A
YYY		Special version

- 1) Suitable fittings and seals must be used for hygienic design in accordance with 3A specifications.
- 2) Suitable fittings and seals must be used for hygienic design in accordance with EHEDG specifications.

170		Material of the process isolating diaphragm:
B		AlloyC
L		Rhodium>gold>AlloyC
Y		Special version
180		Fill fluid:
2		Inert oil
3		Synthetic oil, FDA
9		Special version
190		Seal:
U		None, welded cell

FMB50 (continued)

Additional ordering information (optional)

500	Operating language:	
	AA	English
	AB	German
	AC	French
	AD	Spanish
	AE	Italian
	AF	Dutch
	AK	Chinese
	AL	Japanese
550	Calibration:	
	F1	Factory calibration certificate, 5-point
	F2	DKD calibration certificate 10-point
570	Service:	
	HA	Oil and grease removed ¹⁾
	HB	Cleaned for oxygen service ¹⁾
	HC	Cleaned for silicone-free applications ¹⁾
	HK	Surface quality Ra<0.38um electropolished (wetted)
	IA	Configured min alarm current
	IB	Configured HART Burst Mode PV
	I9	Special version
1) Only device, not accessory or enclosed accessory		
580	Test, certificate:	
	JA	EN10204-3.1 wetted material, inspection certificate
	JB	NACE MR0175 wetted
	JF	AD2000 pressurized
	KB	EN10204-3.1 wetted material + Ra, (Ra= surface roughness), dimensional check, inspection certificate
	KD	EN10204-3.1 helium leak test, inspection certificate
	KE	EN10204-3.1 pressure test, inspection certificate
	KF	EN10204-3.1 measurement Delta ferrite content, inspection certificate
	KG	EN10204-3.1 PMI test (PMI = positive material identification), inspection certificate
	K9	Special version
590	Other approvals:	
	LW	CoC Certificate of Compliance
600	Separate housing:	
	MA	Cable PE, 2m/80inch + housing mounting bracket, wall/pipe, 304
	MB	Cable PE, 5m/200inch + housing mounting bracket, wall/pipe, 304
	MC	Cable PE, 10m/400inch + housing mounting bracket, wall/pipe, 304
	MH	Cable FEP, 5m/200inch IP69K + housing mounting bracket, wall/pipe, 304
610	Accessory mounted:	
	NA	Overvoltage protection

FMB50 (continued)

620		Accessory enclosed:
	QJ	Welding neck G1-1/2, 316L
	QK	Welding neck G1-1/2, 316L, 3.1, EN10204-3.1 material, inspection certificate
	QL	Weld-in tool adapter G1-1/2, brass
	QP	Welding flange DRD DN50 65mm, 316L
	QR	Welding fl. DRD DN50 65mm, 316L 3.1, EN10204-3.1 material, inspection certificate
	QS	Weld-in tool flange DRD DN50 65mm, brass
	QT	Welding neck Uni D65, 316L
	QU	Welding neck Uni D65, 316L, 3.1, EN10204-3.1 material, inspection certificate
	Q1	Weld-in tool adapter Uni D65, brass
	Q2	Welding neck Uni D85, 316L
	Q3	Welding neck Uni D85, 316L, 3.1, EN10204-3.1 material, inspection certificate
	Q5	Welding neck Uni 6" D65, 316L
	Q6	Welding neck Uni 6" D65, 316L, 3.1, EN10204-3.1 material, inspection certificate
	Q7	Weld-in tool adapter Uni 6" D65, brass
	RA	Adapter Uni > DIN11851 DN40, 316L, slotted nut
	R1	Adapter Uni > DIN11851 DN40, 316L, 3.1, slotted nut, EN10204-3.1 material, inspection certificate
	RB	Adapter Uni > DIN11851 DN50, 316L, slotted nut
	R2	Adapter Uni > DIN11851 DN50, 316L, 3.1, slotted nut, EN10204-3.1 material, inspection certificate
	RC	Adapter Uni > DRD DN50 65mm, 316L
	R3	Adapter Uni > DRD DN50 65mm, 316L, 3.1, EN10201-3.1 material, inspection certificate
	RD	Adapter Uni > Clamp 2", 316L
	R4	Adapter Uni > Clamp 2", 316L, 3.1, EN10201-3.1 material, inspection certificate
	RF	Adapter Uni > Varivent, 316L
	R5	Adapter Uni > Varivent, 316L, 3.1, EN10201-3.1 material, inspection certificate
	RL	Plug-in jack M12
	RM	Plug-in jack M12, 90deg
	RN	Plug-in jack M12, 90deg+5m cable
850		Firmware version:
	78	01.00.zz, HART, DevRev01
895		Identification:
	Z1	Measuring point (TAG)
	Z2	Bus address

You can enter the versions for the specific feature in the following table. The versions entered make up the complete order code.

	10	20	30	40	50	70	80	90	110	170	180	190	500	550	570	580	590	600	610	620	850	895
FMB50 -																						

FMB51

This overview does not mark options which are mutually exclusive.

10	Approval:
AA	For non-hazardous areas
BA	ATEX II 1/2G Ex ia IIC T6
BB	ATEX II 1/2D Ex t IIIC
BD	ATEX II 3G Ex nA IIC T6
BE	ATEX II 2G Ex ia IIC T6
B1	ATEX II 1/2G Ex ia IIC T6 + ATEX II 1/2D, Ex iaD
IA	IEC Ex ia IIC T6 Ga/Gb
ID	IEC Ex t IIIC Da/Db
IE	IEC Ex ic IIC T6 Gc
I1	IEC Ex ia IIC T6 Ga/Gb+Ex ia IIIC Da/Db
CA	CSA C/US IS Cl.I,II,III Div.1 Gr.A-G, C/US IS Cl. I Div.2 Gr. A-D, Ex ia C: zone 0,1,2/US: zone 0,1,2,20,21,22
CC	CSA C/US Cl.II, III Div.1 Gr.E-G US: zone 21,22
CD	CSA General Purpose
FA	FM IS Cl.I,II,III Div.1 Gr.A-G, AEx ia, FM NI Cl.I Div.2 Gr.A-D FM IS: Zone 0,1,2,20,21,22/FM NI: Zone 2
FC	FM DIP Cl.II, III Div.1 Gr.E-G, zone 21,22
FD	FM NI Cl.I Div.2 Gr. A-D, zone 2
99	Special version
20	Output:
2	4-20mA HART
9	Special version
30	Display, operation:
1	LCD, push buttons
2	W/o LCD, push buttons
9	Special version
40	Housing:
I	F31 aluminum
J	F31 aluminum, glass window
Q	F15 stainless steel Hygiene
R	F15 stainless steel Hygiene, glass window
S	F15 stainless steel Hygiene, plastic window
Y	Special version
50	Electrical connection:
A	Gland M20, IP66/68 NEMA4X/6P
C	Thread G1/2, IP66/68 NEMA4X/6P
D	Thread NPT1/2, IP66/68 NEMA4X/6P
I	Connector M12, IP66/68, NEMA4X/6P
M	Connector 7/8", IP66/68, NEMA4X/6P
P	Connector Han7D, 90deg, IP65
V	Valve connector ISO4400 M16, IP64
Y	Special version
70	Sensor range:
1C	100mbar/10kPa/1.5psi relative, 1mH2O/3ftH2O/40inH2O Overload: 4bar/400kPa/60psi
1F	400mbar/40kPa/6psi relative, 4mH2O/13ftH2O/160inH2O Overload: 8bar/800kPa/120psi
1H	1.2bar/120kPa/18psi relative, 12mH2O/40ftH2O/480inH2O Overload: 25bar/2.5MPa/375psi
1M	4bar/400kPa/60psi relative, 40mH2O/133ftH2O/1600inH2O Overload: 25bar/2.5MPa/375psi
1P	10bar/1MPa/150psi relative, 100mH2O/333ftH2O/4000inH2O Overload: 40bar/4MPa/600psi
99	Special version
80	Reference accuracy:
D	Platinum
G	Standard
Y	Special version

FMB51 (continued)

90	Calibration; Unit:	
	A	Sensor range; %
	B	Sensor range; mbar/bar
	C	Sensor range; kPa/MPa
	D	Sensor range; mm/mH ₂ O
	E	Sensor range; inH ₂ O/ftH ₂ O
	F	Sensor range; psi
	J	Customized pressure; see additional spec.
100	Probe connection:	
	80 mm rod, 316L 400...4000 mm
	81 mm rod, AlloyC 400...4000 mm
	85 in rod, 316L 16...160 inch
	86 in rod, AlloyC 16...160 inch
	99	Special version
110	Process connection:	
	Threaded connection	
	GGC	Thread ISO228 G1-1/2, AlloyC
	GGJ	Thread ISO228 G1-1/2, 316L
	RGJ	Thread ANSI MNPT1-1/2, 316L
	ANSI flanges	
	AFJ	2" 150lbs RF, 316/316L, flange ANSI B16.5
	AGJ	3" 150lbs RF, 316/316L, flange ANSI B16.5
	AHJ	4" 150lbs RF, 316/316L, flange ANSI B16.5
	EN flanges	
	CEJ	DN40 PN10/16 B1, 316L, flange EN1092-1
	CFJ	DN50 PN10/16 B1, 316L, flange EN1092-1
	CGJ	DN80 PN10/16 B1, 316L, flange EN1092-1
	CHJ	DN100 PN10/16 B1, 316L, flange EN1092-1
	JIS flanges	
	KEJ	10K 40 RF, 316L, flange JIS B2220
	KFJ	10K 50 RF, 316L, flange JIS B2220
	KGJ	10K 80 RF, 316L, flange JIS B2220
	KHJ	10K 100 RF, 316L, flange JIS B2220
	YYY	Special version
170	Material of the process isolating diaphragm:	
	B	AlloyC
	L	Rhodium>gold>AlloyC
	N	Platinum>gold>AlloyC
	Y	Special version
180	Fill fluid:	
	2	Inert oil
	3	Synthetic oil, FDA
	9	Special version
190	Seal:	
	A	FKM Viton
	J	EPDM
	L	Kalrez 6375
	U	None, welded cell

FMB51 (continued)

Additional ordering information (optional)

500	Operating language:	
	AA	English
	AB	German
	AC	French
	AD	Spanish
	AE	Italian
	AF	Dutch
	AK	Chinese
	AL	Japanese
550	Calibration:	
	F1	Factory calibration certificate, 5-point
570	Service:	
	HA	Oil and grease removed ¹⁾
	HB	Cleaned for oxygen service ¹⁾
	HC	Cleaned for silicone-free applications ¹⁾
	IA	Configured min alarm current
	IB	Configured HART Burst Mode PV
	I9	Special version
1) Only device, not accessory or enclosed accessory		
580	Test, certificate:	
	JA	EN10204-3.1 wetted material, inspection certificate
	JB	NACE MR0175 wetted
	KD	EN10204-3.1 helium leak test, inspection certificate
	KE	EN10204-3.1 pressure test, inspection certificate
	KG	EN10204-3.1 PMI test (PMI = positive material identification), inspection certificate
	K9	Special version
600	Separate housing:	
	MA	Cable PE, 2m/80inch + housing mounting bracket, wall/pipe, 304
	MB	Cable PE, 5m/200inch + housing mounting bracket, wall/pipe, 304
	MC	Cable PE, 10m/400inch + housing mounting bracket, wall/pipe, 304
	MH	Cable FEP, 5m/200inch IP69K + housing mounting bracket, wall/pipe, 304
610	Accessory mounted:	
	NA	Overvoltage protection
620	Accessory enclosed:	
	QJ	Welding neck G1-1/2, 316L
	QK	Welding neck G1-1/2, 316L, 3.1, EN10204-3.1 material, inspection certificate
	QL	Weld-in tool adapter G1-1/2, brass
	RL	Plug-in jack M12
	RM	Plug-in jack M12, 90deg
	RN	Plug-in jack M12, 90deg+5m cable
850	Firmware version:	
	78	01.00.zz, HART, DevRev01
895	Identification:	
	Z1	Measuring point (TAG)
	Z2	Bus address

You can enter the versions for the specific feature in the following table. The versions entered make up the complete order code.

	10	20	30	40	50	70	80	90	100	110	170	180	190	500	550	570	580	600	610	620	850	895	
FMB51 -																							

FMB52

This overview does not mark options which are mutually exclusive.

10	Approval:	
	AA	For non-hazardous areas
	BA	ATEX II 1/2G Ex ia IIC T6
	BD	ATEX II 3G Ex nA IIC T6
	BE	ATEX II 2G Ex ia IIC T6
	IA	IEC Ex ia IIC T6 Ga/Gb
	IC	IEC Ex ia IIC T6 Gb
	IE	IEC Ex ic IIC T6 Gc
	CA	CSA C/US IS Cl. I, II, III Div.1 Gr. A-G, CSA C/US IS Cl. I Div. 2 Gr. A-D, Ex ia C: Zone 0,1,2/US: Zone 0,1,20,21,22
	CD	CSA General Purpose
	FE	FM IS Cl.I Div.1 Gr.A-D, AEx ia, Zone 0,1,2
	99	Special version
20	Output:	
	2	4-20mA HART
	9	Special version
30	Display, operation:	
	1	LCD, push buttons
	2	W/o LCD, push buttons
	9	Special version
40	Housing:	
	I	F31 aluminum
	J	F31 aluminum, glass window
	Q	F15 stainless steel Hygiene
	R	F15 stainless steel Hygiene, glass window
	S	F15 stainless steel Hygiene, plastic window
	Y	Special version
50	Electrical connection:	
	A	Gland M20, IP66/68 NEMA4X/6P
	C	Thread G1/2, IP66/68 NEMA4X/6P
	D	Thread NPT1/2, IP66/68 NEMA4X/6P
	I	Connector M12, IP66/68, NEMA4X/6P
	M	Connector 7/8", IP66/68, NEMA4X/6P
	P	Connector Han7D, 90deg, IP65
	V	Valve connector ISO4400 M16, IP64
	Y	Special version
70	Sensor range:	
	1C	100mbar/10kPa/1.5psi relative, 1mH2O/3ftH2O/40inH2O Overload: 4bar/400kPa/60psi
	1F	400mbar/40kPa/6psi relative, 4mH2O/13ftH2O/160inH2O Overload: 8bar/800kPa/120psi
	1H	1.2bar/120kPa/18psi relative, 12mH2O/40ftH2O/480inH2O Overload: 25bar/2.5MPa/375psi
	1M	4bar/400kPa/60psi relative, 40mH2O/133ftH2O/1600inH2O Overload: 25bar/2.5MPa/375psi
	1P	10bar/1MPa/150psi relative, 100mH2O/333ftH2O/4000inH2O Overload: 40bar/4MPa/600psi
	99	Special version
80	Reference accuracy:	
	D	Platinum
	G	Standard
	Y	Special version
90	Calibration; Unit:	
	A	Sensor range; %
	B	Sensor range; mbar/bar
	C	Sensor range; kPa/MPa
	D	Sensor range; mm/mH2O
	E	Sensor range; inH2O/ftH2O
	F	Sensor range; psi
	J	Customized pressure; see additional spec.
	K	Customized level; see additional spec.
	Y	Special version

FMB52 (continued)

100 Probe connection:		
15 mm cable, PE	500...400.000 mm
25 in cable, PE	500...400.000 mm
35 mm cable, FEP	20...15748 inch
45 in cable, FEP	20...15748 inch
99	Special version	
110 Process connection:		
Threaded connection		
GGC	Thread ISO228 G1-1/2, AlloyC	
GGJ	Thread ISO228 G1-1/2, 316L	
RGJ	Thread ANSI MNPT1-1/2, 316L	
ANSI flanges		
AFJ	2" 150lbs RF, 316/316L, flange ANSI B16.5	
AGJ	3" 150lbs RF, 316/316L, flange ANSI B16.5	
AHJ	4" 150lbs RF, 316/316L, flange ANSI B16.5	
EN flanges		
CEJ	DN40 PN10/16 B1, 316L, flange EN1092-1	
CFJ	DN50 PN10/16 B1, 316L, flange EN1092-1	
CGJ	DN80 PN10/16 B1, 316L, flange EN1092-1	
CHJ	DN100 PN10/16 B1, 316L, flange EN1092-1	
JIS flanges		
KEJ	10K 40 RF, 316L, flange JIS B2220	
KFJ	10K 50 RF, 316L, flange JIS B2220	
KGJ	10K 80 RF, 316L, flange JIS B2220	
KHJ	10K 100 RF, 316L, flange JIS B2220	
YYY	Special version	
170 Material of the process isolating diaphragm:		
B	AlloyC	
L	Rhodium>gold>AlloyC	
N	Platinum>gold>AlloyC	
Y	Special version	
180 Fill fluid:		
2	Inert oil	
3	Synthetic oil, FDA	
9	Special version	
190 Seal:		
A	FKM Viton	
J	EPDM	
L	Kalrez 6375	
U	None, welded cell	

FMB52 (continued)

Additional ordering information (optional)

500	Operating language:	
	AA	English
	AB	German
	AC	French
	AD	Spanish
	AE	Italian
	AF	Dutch
	AK	Chinese
	AL	Japanese
550	Calibration:	
	F1	Factory calibration certificate, 5-point
570	Service:	
	HA	Oil and grease removed ¹⁾
	HC	Cleaned for silicone-free applications ¹⁾
	IA	Configured min alarm current
	IB	Configured HART Burst Mode PV
	I9	Special version
1) Only device, not accessory or enclosed accessory		
580	Test, certificate:	
	JA	EN10204-3.1 wetted material, inspection certificate
	JB	NACE MR0175 wetted
	KD	EN10204-3.1 helium leak test, inspection certificate
	KE	EN10204-3.1 pressure test, inspection certificate
	KG	EN10204-3.1 PMI test (PMI = positive material identification), inspection certificate
	K9	Special version
600	Separate housing:	
	MA	Cable PE, 2m/80inch + housing mounting bracket, wall/pipe, 304
	MB	Cable PE, 5m/200inch + housing mounting bracket, wall/pipe, 304
	MC	Cable PE, 10m/400inch + housing mounting bracket, wall/pipe, 304
	MH	Cable FEP, 5m/200inch IP69K + housing mounting bracket, wall/pipe, 304
610	Accessory mounted:	
	NA	Overvoltage protection
620	Accessory enclosed:	
	QJ	Welding neck G1-1/2, 316L
	QK	Welding neck G1-1/2, 316L, 3.1, EN10204-3.1 material, inspection certificate
	QL	Weld-in tool adapter G1-1/2, brass
	RL	Plug-in jack M12
	RM	Plug-in jack M12, 90deg
	RN	Plug-in jack M12, 90deg+5m cable
850	Firmware version:	
	78	01.00.zz, HART, DevRev01
895	Identification:	
	Z1	Measuring point (TAG)
	Z2	Bus address

You can enter the versions for the specific feature in the following table. The versions entered make up the complete order code.

	10	20	30	40	50	70	80	90	100	110	170	180	190	500	550	570	580	600	610	620	850	895
FMB52 -																						

FMB53

This overview does not mark options which are mutually exclusive.

10	Approval:
AA	For non-hazardous areas
BE	ATEX II 2G Ex ia IIC T6
BG	ATEX II 3G Ex ic IIC T6
IC	IEC Ex ia IIC T6 Gb
IE	IEC Ex ic IIC T6 Gc
CA	CSA C/US IS Cl. I, II, III Div.1 Gr. A-G, CSA C/US IS Cl. I Div. 2 Gr. A-D, Ex ia
CD	CSA General Purpose
FE	FM IS Cl.I Div.1 Gr.A-D, AEx ia, Zone 0,1,2
99	Special version
20	Output:
2	4-20mA HART
9	Special version
30	Display, operation:
1	LCD, push buttons
2	W/o LCD, push buttons
9	Special version
40	Housing:
I	F31 aluminum
J	F31 aluminum, glass window
Q	F15 stainless steel Hygiene
R	F15 stainless steel Hygiene, glass window
S	F15 stainless steel Hygiene, plastic window
Y	Special version
50	Electrical connection:
A	Gland M20, IP66/68 NEMA4X/6P
C	Thread G1/2, IP66/68 NEMA4X/6P
D	Thread NPT1/2, IP66/68 NEMA4X/6P
I	Connector M12, IP66/68, NEMA4X/6P
M	Connector 7/8", IP66/68, NEMA4X/6P
P	Connector Han7D, 90deg, IP65
V	Valve connector ISO4400 M16, IP64
Y	Special version
70	Sensor range:
1C	100mbar/10kPa/1.5psi relative, 1mH2O/3ftH2O/40inH2O Overload: 4bar/400kPa/60psi
1F	400mbar/40kPa/6psi relative, 4mH2O/13ftH2O/160inH2O Overload: 8bar/800kPa/120psi
1H	1.2bar/120kPa/18psi relative, 12mH2O/40ftH2O/480inH2O Overload: 25bar/2.5MPa/375psi
1M	4bar/400kPa/60psi relative, 40mH2O/133ftH2O/1600inH2O Overload: 25bar/2.5MPa/375psi
1P	10bar/1MPa/150psi relative, 100mH2O/333ftH2O/4000inH2O Overload: 40bar/4MPa/600psi
99	Special version
80	Reference accuracy:
D	Platinum
G	Standard
Y	Special version
90	Calibration; Unit:
A	Sensor range; %
B	Sensor range; mbar/bar
C	Sensor range; kPa/MPa
D	Sensor range; mm/mH2O
E	Sensor range; inH2O/ftH2O
F	Sensor range; psi
J	Customized pressure; see additional spec.
K	Customized level; see additional spec.
Y	Special version

FMB53 (continued)

100		Probe connection:	
	15 m cable, can be shortened, PE	0,5...400 m
	25 ft cable, can be shortened, PE	0,5...400 m
	35 m cable, can be shortened, FEP	2...1312 inch
	45 ft cable, can be shortened, FEP	2...1312 inch
	99	Special version	
170		Material of the process isolating diaphragm:	
	B	AlloyC	
	L	Rhodium>gold>AlloyC	
	N	Platinum>gold>AlloyC	
	Y	Special version	
180		Fill fluid:	
	2	Inert oil	
	3	Synthetic oil, FDA	
	9	Special version	
190		Seal:	
	A	FKM Viton	
	J	EPDM	
	L	Kalrez 6375	
	U	None, welded cell	
	Y	Special version	

FMB53 (continued)

Additional ordering information (optional)

500	Operating language:	
	AA	English
	AB	German
	AC	French
	AD	Spanish
	AE	Italian
	AF	Dutch
	AK	Chinese
	AL	Japanese

550	Calibration:	
	F1	Factory calibration certificate, 5-point

570	Service:	
	HA	Oil and grease removed ¹⁾
	HC	Cleaned for silicone-free applications ¹⁾
	IA	Configured min alarm current
	IB	Configured HART Burst Mode PV
	I9	Special version

1) Only device, not accessory or enclosed accessory

580	Test, certificate:	
	JA	EN10204-3.1 wetted material, inspection certificate
	JB	NACE MR0175 wetted
	KD	EN10204-3.1 helium leak test, inspection certificate
	KE	EN10204-3.1 pressure test, inspection certificate
	KG	EN10204-3.1 PMI test (PMI = positive material identification), inspection certificate
	K9	Special version

610	Accessory mounted:	
	NA	Overvoltage protection

620	Accessory enclosed:	
	PO	Suspension clamp, 316L
	PW	Extension cable shortening kit
	RL	Plug-in jack M12
	RM	Plug-in jack M12, 90deg
	RN	Plug-in jack M12, 90deg+5m cable

850	Firmware version:	
	78	01.00.zz, HART, DevRev01

895	Identification:	
	Z1	Measuring point (TAG)
	Z2	Bus address

You can enter the versions for the specific feature in the following table. The versions entered make up the complete order code.

	10	20	30	40	50	70	80	90	100	170	180	190	500	550	570	580	610	620	850	895	
FMB53 -																					

Documentation

Technical Information

- EMC test procedures: TI241F
- Deltabar M: TI434P/00/EN
- Cerabar M: TI436P/00/EN

Operating Instructions

- 4 to 20 mA HART:
- Cerabar M, Deltabar M, Deltapilot M: BA382P/00/EN

Brief Operating Instructions

- 4 to 20 mA HART:
- Deltapilot M: KA1033P/00/EN
- Field Xpert: BA060S/04/EN

Safety Instructions

Authorities	Version in the order code	Approval	Category	Type	Electronics	Documentation
ATEX	BA	Ex ia IIC	II 1/2 G	FMB50, FMB51, FMB52	– 4 to 20 mA HART	– XA474P
	BB	Ex t IIC	II 1/2 D	FMB50, FMB51	– 4 to 20 mA HART	– XA475P
	BD	Ex nA	II 3 G	FMB50, FMB51, FMB52, FMB53	– 4 to 20 mA HART	– XA477P
	BE	Ex ia IIC	II 2 G	FMB50, FMB51, FMB52, FMB53	– 4 to 20 mA HART	– XA474P
	BG	Ex ic IIC	II 3 G	FMB50, FMB51, FMB52, FMB53	– 4 to 20 mA HART	– XA494P
	B1	Ex ia IIC Ex ia IIC	II 1/2 G II 1/2 D	FMB50, FMB51	– 4 to 20 mA HART	– XA476P

Authorities	Version in the order code	Approval	EPL	Type	Electronics	Documentation
IECEX	IA	Ex ia IIC	Ga/Gb	FMB50, FMB51, FMB52	– 4 to 20 mA HART	– XA478P
	IC	Ex ia IIC	Gb	FMB52, FMB53	– 4 to 20 mA HART	– XA478P
	ID	Ex t IIIC	Da/Db	FMB50, FMB51	– 4 to 20 mA HART	– XA479P
	IE	Ex ic IIC	Gc	FMB50, FMB51, FMB52, FMB53	– 4 to 20 mA HART	– XA493P
	I1	Ex ia IIC Ex ia IIIC	Ga/Gb Da/Db	FMB50, FMB51	– 4 to 20 mA HART	– XA480P

Installation/Control Drawings

Authorities	Version in the order code	Approval	Type	Electronics	Documentation
FM	FA	FM IS Cl.I,II,III Div.1 Gr.A-G, AEx ia, FM NI Cl.I Div.2 Gr.A-D, FM IS: Zone 0,1,2,20,21,22/FM NI: Zone 2	FMB50	- 4...20 mA HART	- ZD236P
		FM IS Cl.I,II,III Div.1 Gr.A-G, AEx ia, Zone 0,1,2,20,21,22	FMB51	- 4...20 mA HART	-
	FC	FM DIP Cl.II,III Div.1 Gr.E-G, Zone 21,22	FMB50, FMB51	- 4...20 mA HART	-
CSA	CA	C/US IS Cl.I,II,III Div.1 Gr.A-G, C/US IS Cl.I Div.2 Gr.A-D, Ex ia, Zone 0,1,2	FMB50, FMB53	- 4...20 mA HART	- ZD239P
		C/US IS Cl.I,II,III Div.1 Gr.A-G, C/US IS Cl.I Div.2 Gr.A-D, Ex ia C: Zone 0,1,2/ US: Zone 0,1,2,20,21,22	FMB51, FMB52	- 4...20 mA HART	-
	CC	CSA C/US Cl.II, III Div.1 Gr.E-G	FMB50	- 4...20 mA HART	-
		CSA C/US Cl.II, III Div.1 Gr.E-G US: Zone 21,22	FMB51	- 4...20 mA HART	-

Accessories

Suspension clamp (FMB53 only) → 18 ff

Extension cable shortening kit (FMB53 only) → 43 ff, feature 620, "Accessory enclosed", version "PW". For details refer to SD553P/00/a2.

M12 connector → 14 ff

Welding necks and Weld-in tool flanges

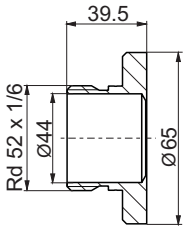
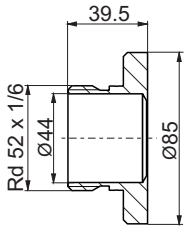
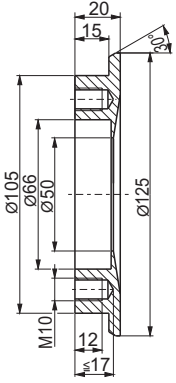
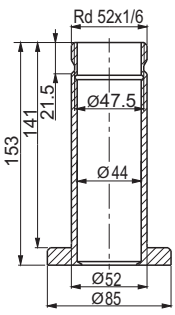
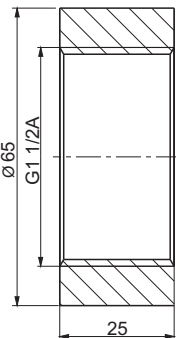
	 P01-PMx5xxxx-06-xx-xx-xx-008	 P01-PMx5xxxx-06-xx-xx-xx-009	 P01-PMx5xxxx-06-xx-xx-xx-010	 P01-PMx5xxxx-11-xx-xx-xx-011	 P01-PMx5xxxx-06-xx-xx-xx-005
Typ	Uni D65	Uni D85	DRD DN50	Uni extens. 6" D85	G1-1/2, flush mounted
Material	316L				
Order	→ 43 ff, feature 620, "Accessory enclosed", versions see following table rows				
FMB50	QT / QU	Q2 / Q3	QP / QR	Q5 / Q6	QJ / QK
FMB51	—	—	—	—	QJ / QK
FMB52	—	—	—	—	QJ / QK
Weld-in tool adapters					
Material	brass				
FMB50	Q1	Q1	QS	Q7	QL
FMB51	—	—	—	—	QL
FMB52	—	—	—	—	QL

UNI process adapter

	<p>P01-PMx5xxxx-11-xx-xx-xx-006</p>	<p>P01-PMx5xxxx-11-xx-xx-xx-006</p>	<p>P01-PMx5xxxx-11-xx-xx-xx-006</p>
Typ	DIN11851 DN40	DIN11851 DN50	DRD DN50
Material	316L		
Order	→ 43 ff, feature 620, "Accessory enclosed", versions see following table row		
FMB50	RA / R1	RB / R2	RC / R3

	<p>P01-PMx5xxxx-11-xx-xx-xx-006</p>	<p>P01-PMx5xxxx-11-xx-xx-xx-006</p>
Typ	Clamp 2"	Varivent
Material	316L	
Order	→ 43 ff, feature 620, "Accessory enclosed", versions see following table row	
FMB50	RD / R4	RF / R6

Pressure

The following configuration data sheet has to be filled in and included with the order if the version "J - Customized pressure" has been selected in feature 90 "Calibration; unit" in the product structure.

Pressure Engineering Unit			
<input type="checkbox"/> mbar	<input type="checkbox"/> mmH2O	<input type="checkbox"/> mmHg	<input type="checkbox"/> Pa
<input type="checkbox"/> bar	<input type="checkbox"/> mH2O		<input type="checkbox"/> kPa
<input type="checkbox"/> psi	<input type="checkbox"/> ftH2O	<input type="checkbox"/> kgf/cm ²	<input type="checkbox"/> MPa
<input type="checkbox"/> inH2O			
Calibration Range / Output			
Low range value (LRV): _____		[pressure engineering unit]	
Upper range value (URV): _____		[pressure engineering unit]	
Display Information			
1st Value Display		2nd Value display	
Main Value		<input type="checkbox"/> none (default)	
		<input type="checkbox"/> Pressure	
		<input type="checkbox"/> Current [mA]	
		<input type="checkbox"/> Temperature	
		<input type="checkbox"/> Measured value (%)	
Damping			
Damping: ____ sec (Default 2 sec)			

P01-xxxxxxxx-10-xx-xx-xx-001

Note!
Smallest span (factory calibration) → 9.

Instruments International

Endress+Hauser
Instruments International AG
Kaegenstrasse 2
4153 Reinach
Switzerland

Tel. +41 61 715 81 00
Fax +41 61 715 25 00
www.endress.com
info@ii.endress.com

Endress+Hauser 

People for Process Automation

