

**Y2K**  
Compliant



## InterRanger DPS 300

Dual Point  
Interface Detection and  
Monitoring System  
For Automated  
Clarifier Control

 **MILLTRONICS**

# Reduce Operating Costs While Improving Plant Efficiency

## The InterRanger DPS 300 is a cost effective, dual point ultrasonic system for accurate sludge level monitoring and automated clarifier control

In many water and wastewater plants, getting accurate sludge level data is often a weak link in the drive to maximize overall plant efficiency. Manual methods of blanket measurement are not consistent, while many contacting devices require frequent maintenance.

## With the DPS 300, effective control of your clarifier process is no longer an uphill battle

The non-contacting InterRanger DPS 300 system provides the water and wastewater industry with advanced, reliable continuous measurement of primary and secondary clarifiers, utilizing the latest ultrasonic techniques. Combined with remote monitoring and

control, you have everything you need for a truly efficient and automated operation.

Unlike error-prone manual methods, the DPS 300 system uses Milltronics' patented echo processing techniques to deliver continuous, reliable blanket measurement week-in and week-out.

It is the only interface detector with a dual frequency monitor which ensures accurate, repeatable sludge blanket measurement in both heavy and light conditions. Now you can say goodbye to guesswork that could result in accidental environmental permit violations or process upsets.



Setting up the DPS 300 on-site with the infrared, handheld programmer. Electronics are not exposed.



**Improving performance at the clarification stages of the treatment process has a positive impact on process efficiencies downstream. This contributes to meeting accelerating demands on water and wastewater treatment operations for:**

- Improved effluent quality, by maximizing solids removal from influent
- Increased throughput volume
- Compliance with more stringent environmental permit regulations
- Tightening operating budgets
- Minimizing process upsets
- Reduction of capital expenditures and plant expansion requirements

One or two circular or rectangular clarifiers can be monitored, simultaneously, with just one instrument. The system includes one Echomax XCT-12 transducer for each clarifier, mounted just below the liquid surface. These hermetically-sealed sensors have an extremely active face and can be submerged for extended periods of time without fouling or maintenance.

# Minimize Sludge Handling Costs Maximize Overall Plant Process Control

## Flexible digital fieldbus communications options allow integrated clarifier control

The InterRanger DPS 300 has on-board communications for integration with plant-wide PLC, DCS or SCADA systems. You have access to all information required to cut non-productive time spent on troubleshooting and to reduce maintenance costs. Instead of operating on what happened yesterday, sludge levels can be regulated automatically, 24 hours a day, to attain peak efficiency from primary and secondary clarifiers. And, by automating corrective actions to alarm or non-standard operating conditions, overall plant performance and effluent flow capacity is improved.

The system is compatible with Milltronics' modular, plug-in SmartLinX™ interface module – for direct connection to popular industrial buses. The appropriate SmartLinX™ module can be installed at any time.

The communication port is completely flexible, providing RS-232 / RS-485 for Dolphin Plus, or a BIC II connection with Milltronics' bi-polar loop.



*By installing the DPS 300 with Dolphin Plus, an operator can "see" the sludge level profile to verify unit performance.*

## Fast, problem-free set-up and operation, at the instrument or remotely

The InterRanger DPS 300 is pre-calibrated for most sludge blanket detection applications. Operation is based on the same ultrasonic technology that many operators are already using on a daily basis, resulting in minimal training and fast set-up and operation.

*Consider these benefits when you automate monitoring and control of sludge blanket measurement with an InterRanger DPS 300:*

### **Primary Clarification Stage**

- Improved effluent quality due to a higher ratio of solids removal from influent
- Reduced sludge handling – only compacted sludge is sent to digesters/dryers
- Early warning of process upset conditions

### **Secondary Clarification Stage**

- Reduced sludge maintenance costs
- Better return activated sludge (RAS) handling because specified quantities of sludge are sent to aerators
- Lower operating costs in both the primary and secondary clarification stages through reductions in chemical usage, labour and sludge pump maintenance as well as optimization of flocculent additions

## Dolphin Plus software saves time and improves plant documentation

You can use the hand programmer to communicate with the electronics or configure and diagnose the instrument remotely with Milltronics' Dolphin Plus software and a laptop or standard PC. This Windows 95®-based configuration software provides remote connection, or local interface through the infrared ComVerter. You can set-up the DPS 300, change parameters, upload or download parameter files and diagnose the instrument without leaving your desk. It's simple to use with HELP files at your fingertips.

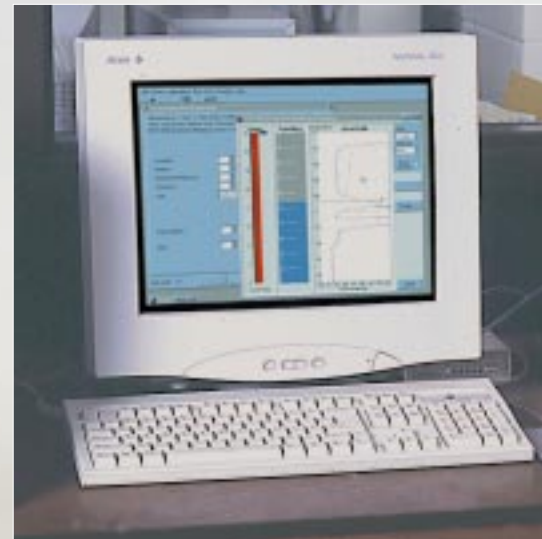

# How the InterRanger DPS 300 Works

The DPS 300 system consists of an electronic monitor and one or two Echomax® XCT-12 transducers with a mounting assembly and optional skimmer guard(s).

The transducer, with the face submerged below the liquid surface, continuously sends high frequency sonic

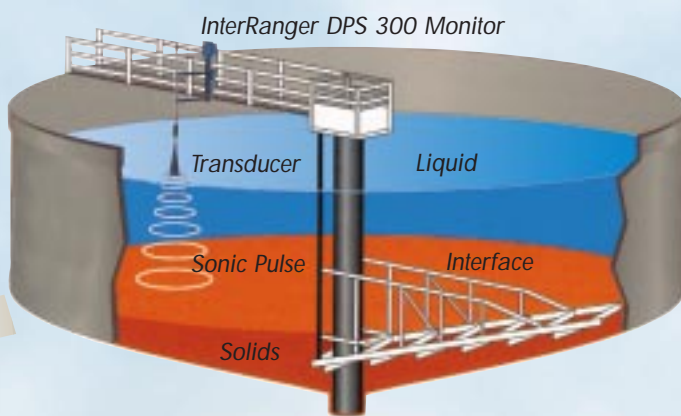

pulses through the liquid towards the bottom of the clarifier. The return echoes, reflected from the sludge interface present in the tank, are captured for processing with Milltronics' patented Sonic Intelligence® software. The round trip time of each sonic pulse from the transducer face to the sludge blanket is digitally converted into distance or level measurement and displayed in the selected linear engineering unit on the backlit LCD readout.

To optimize accuracy, output is automatically temperature compensated.

The DPS 300 has been used to detect a 4% suspended solids layer in turbid wastewater, typical of primary clarifiers, and a 0.2% layer in "clear" wastewater, typical of secondary clarifiers.

**Milltronics. Working to provide intelligent water management solutions to our customers.**

## The Sonic Intelligence® Advantage

The advanced echo processing techniques of Sonic Intelligence software makes sludge blanket data from the DPS 300 consistently reliable. It not only differentiates between the real echo and echoes generated by acoustical or electrical noise but also captures weak "true" echoes in harsh environments and in conditions with obstructions, turbulence and foam.

By using proven ultrasonic echo ranging principles with Sonic Intelligence and velocity compensation, the DPS 300 delivers outstanding measurement accuracy, up to 1% of range, depending on process conditions.

*The InterRanger DPS 300  
in a rectangular clarifier.*



# InterRanger DPS 300

## Key Features and Benefits

- Dual point scanning of sludge blanket levels in circular or rectangular clarifiers from 1m to 30m (3 ft. to 100 ft.). Low cost per point
- Proven echo analysis with patented Sonic Intelligence® software ensures reliable data
- The only interface detector with a dual frequency monitor for accurate sludge level detection under dynamic conditions
- Flexible, on-board communications to DCS, PLC or SCADA control systems automates clarifier control
- Continuous, remote blanket monitoring, improves process efficiency, increases throughput
- SmartLinX™ compatible for direct connection to popular industrial buses. An appropriate SmartLinX™ module can be installed at any time. Provides full parameter access and reduces maintenance and wiring costs
- Compact, durable Type 4X/NEMA 4X/IP 65 polycarbonate enclosure with easily accessible electronics and wiring. Can be mounted 365m (1200 ft.) from the sensor(s)
- Fast, problem-free set-up and operation. Pre-calibrated for most sludge blanket detection applications. Reduces set-up and training time
- Remote system set-up and diagnostics with a laptop or standard PC and Dolphin Plus Windows 95®-based software, saves time, improves plant performance documentation
- Simple to install. Pre-fabricated epoxy-coated aluminum mounting assembly ensures secure installation. In clarifiers with surface skimmers, a unique skimmer guard protects transducer(s) from damage
- Non-contacting. Hermetically-sealed Echomax XCT-12 transducer(s) can be submerged for extended periods of time without fouling or maintenance

***If you are looking for blanket measurement that is automated, reliable and, above all efficient, there's only one game in town.***

***Milltronics.***

*This compact system is designed for simple installation and rugged use. It comes with a pre-fabricated, epoxy-coated aluminum assembly for mounting on standard tubular railings.*

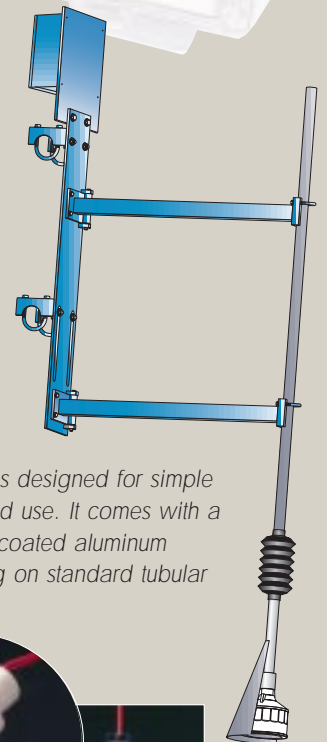

*In a clarifier equipped with a surface skimmer, a protective skimmer guard with a durable knuckle joint allows the transducer to ride up over the skimmer arm on contact.*



# Specifications

## OPERATIONS

Measurement Range	1m to 30m (3 ft. to 100 ft.)
Process Application	Interface level measurement in liquids
Accuracy and Resolution	1% of program range* or 2cm (0.8") whichever is greater
Temperature (sensor)	-40 to 145°C (-40 to 293°F). 2 TS-3 temperature sensors maximum
Temperature Compensation	Built-in temperature sensor
Electronics: Ambient Temp.	-20 to 50°C (-5 to 122°F)
Echo Processing	Sonic Intelligence® software
Power Supply – ac	100/115/200/230 V ac ±15%, 50/60 Hz, 31 VA

## INTERFACE

Outputs: Transducer Drive	150 to 315 V peak
Relays	4 programmable alarm / control relays 1 form "C" SPDT contact per relay, rated 5A at 250 V ac, non-inductive
Analog	2 outputs max. 0-20 or 4-20 mA, scalable. 0.1% resolution. 750 Ω, isolated
Display	Backlit LCD with 51mm x 127mm (2" x 5") viewing area and custom graphics
Communications	RS-232, RS-485, bi-polar current loop, SmartLinX™ ready

<b>ENCLOSURE:</b> Wall Mount	Type 4X / NEMA 4X / IP65 polycarbonate 285mm W x 209mm H x 92mm D (11.2" W x 8.2" H x 3.6" D)
Weight	2.7 kg (6 lb.)

<b>PROGRAMMING</b>	Via removable infrared programmer or optional Dolphin Plus, Milltronics Windows 95®-based software interface and infrared ComVerter link
Memory	EEPROM (non-volatile). No back-up battery required

<b>PROGRAMMER</b>	Hand held, 20 keys, 67mm x 100mm x 25mm (2.6" x 4" x 1") general purpose enclosure
-------------------	--

<b>COMMUNICATIONS OPTIONS</b>	For connection to PLC, DCS, or SCADA Systems
SmartLinX™	Interface modules that allow direct connection to popular industrial communication networks
BIC II	BIC II converts the bi-polar communication current loop to remote RS-232 or RS-422

## MOUNTING HARDWARE

Base Plate and Railing Brackets	Epoxy coated aluminum. Fits 5 cm (2") tubular railings with a 43 cm to 60 cm (17" to 24") spacing
Mounting Plate and Extension Arms	Epoxy coated aluminum
Skimmer Guard and Knuckle Joint	2 stainless steel models available for skimmers from 1cm to 20cm (1" to 8") and 20cm to 40cm (8" to 16"). Uni-directional, stainless steel knuckle joint
Fasteners	Stainless steel used throughout
Weight	15 kg (33 lbs.)

<b>InterRanger DPS 300 Compatible Transducer: ECHOMAX® XCT-12 MODEL – White Kynar Housing, IP 68</b>	
Beam Angle	22°
Frequency	Dual frequency 50 KHz and 150 KHz
Cable Type	2-wire shielded/twisted 0.52mm <sup>2</sup> (20 AWG), silicone jacket
Maximum Run	Up to 365m (1200 ft.) using RG-62 A/U coaxial cable, or 100m (330 ft.) using 18 AWG shielded twisted pair
Conduit Connection	1" NPT, 1" BSP

<b>APPROVALS</b>	<b>InterRanger DPS 300:</b> CE**, CSA <sub>NRTL/C</sub> . Pending: FM. <b>XCT-12:</b> CE**, CSA. FM. CENELEC
------------------	--