

Lightweight Up to **15% Weight reduced**

* Compared with the previous CP96 series (ø40, 100 mm stroke)

■ By adopting a new cushion method (Air cushion + Bumper cushion),

Cycle time shortened

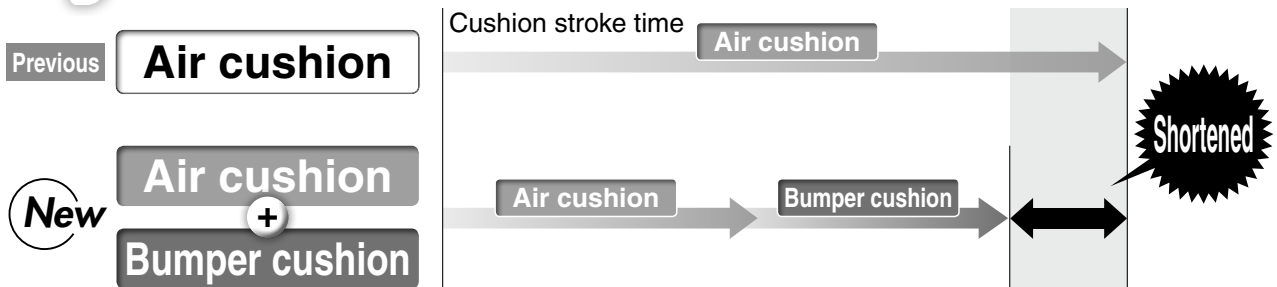

■ Bumper cushion reduces the metal noise that occurs when piston stops

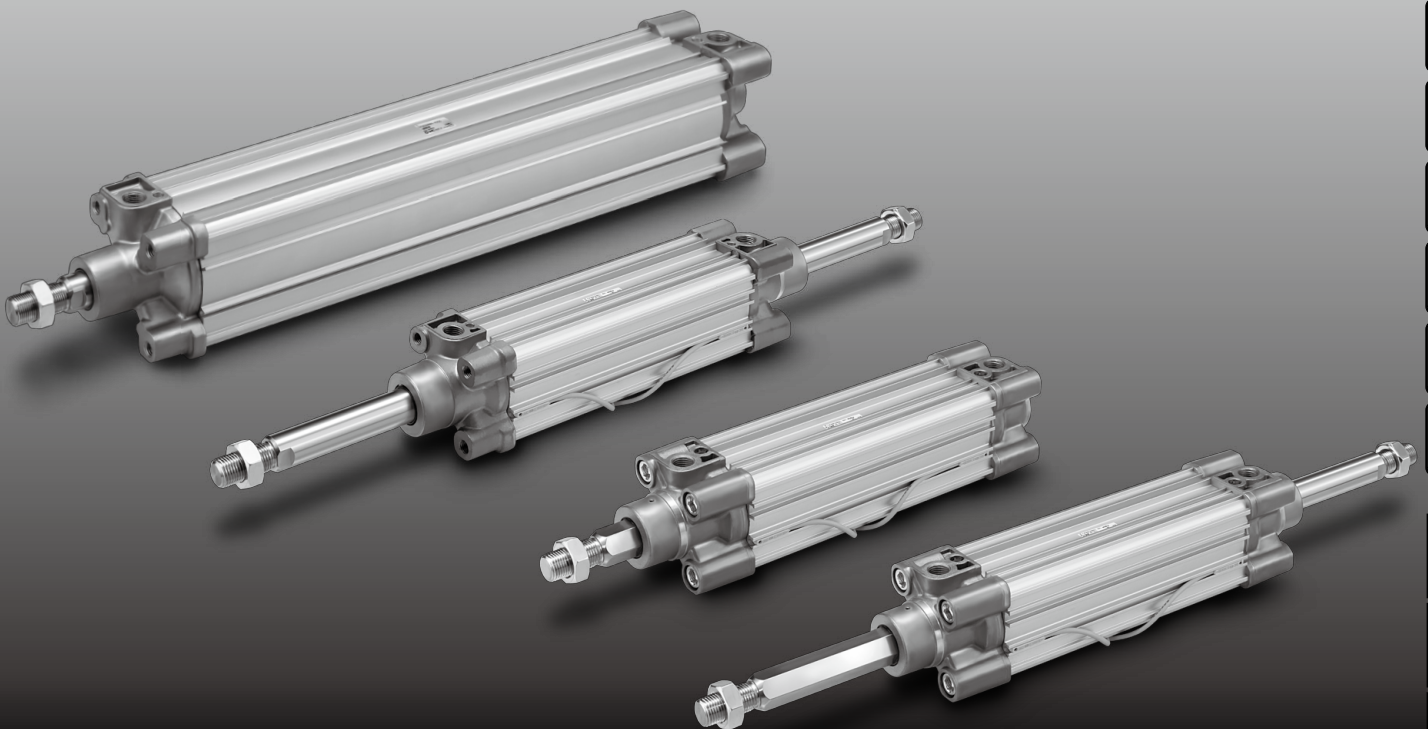

C85
C85W
C85-ST
C85K
C85K-ST
C85R
C75
C75W
C75-ST
C75K
C75K-ST
C75R
CP96
CP96K
C96
C96K
C96Y
C55
Auto Switch
Made to Order
Related Products

Dimensions

Basic: CP96S (D) B Bore size - Stroke C (J) W

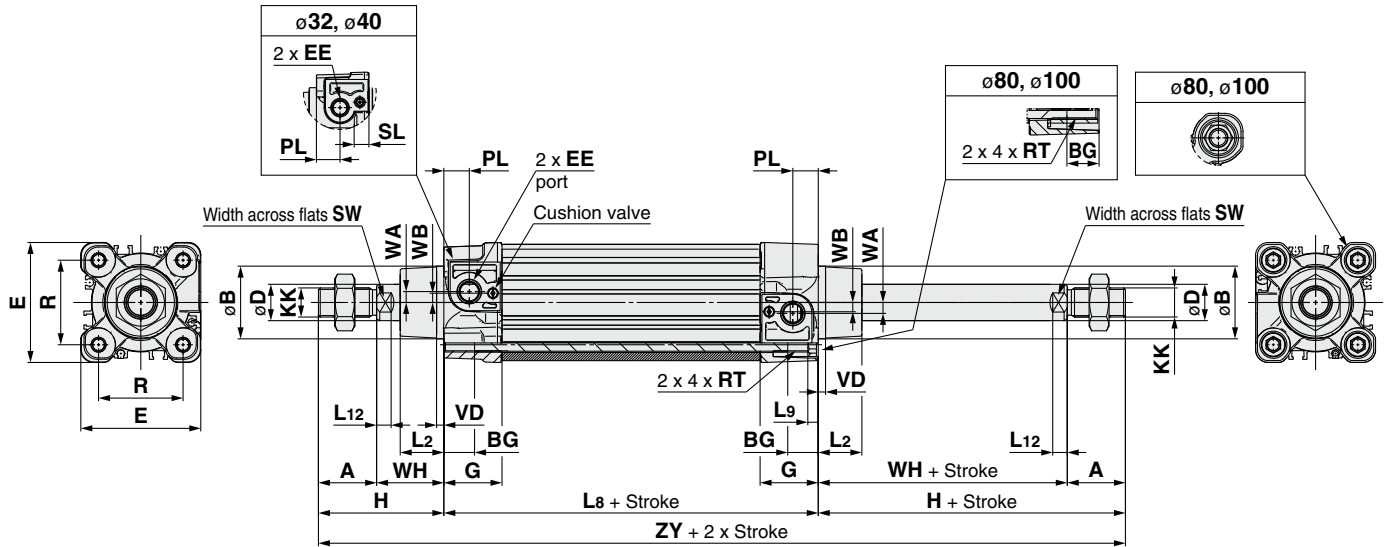

With rod boot at one end

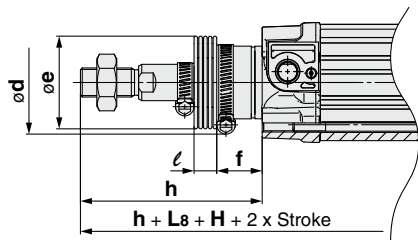

Bore size [mm]	Stroke range [mm]	A	ϕB d11	ϕD	EE	PL	RT	L12	KK	SW	G	BG	L8	VD	WA	WB	WH	ZY	E	R	L2	L9	H	SL
32	Up to 1000	22	30	12	G 1/8	13	M6 x 1	6	M10 x 1.25	10	28.9	16	94	4	4	7	26	190	47	32.5	15	4	48	8
40	Up to 1000	24	35	16	G 1/4	14	M6 x 1	6.5	M12 x 1.25	13	32.6	16	105	4	5	8.9	30	213	54	38	17	4	54	8
50	Up to 1000	32	40	20	G 1/4	14	M8 x 1.25	8	M16 x 1.5	17	32	16	106	4	6	5.1	37	244	66	46.5	24	5	69	—
63	Up to 1000	32	45	20	G 3/8	16	M8 x 1.25	8	M16 x 1.5	17	38.6	16	121	4	9	6.3	37	259	77	56.5	24	5	69	—
80	Up to 1000	40	45	25	G 3/8	16	M10 x 1.5	10	M20 x 1.5	22	38.4	17	128	4	11.5	6	46	300	99	72	30	—	86	—
100	Up to 1000	40	55	25	G 1/2	18	M10 x 1.5	10	M20 x 1.5	22	42.9	17	138	4	17	10	51	320	118	89	32	—	91	—

Bore size [mm]	ϕe	ϕd	f	ℓ										h													
				1 to 50	51 to 100	101 to 150	151 to 200	201 to 300	301 to 400	401 to 500	501 to 600	601 to 700	701 to 800	801 to 900	901 to 1000	1	51	101	151	201	301	401	501	601	701	801	901
32	36	54	23	12.5	25	37.5	50	75	100	125	150	175	200	225	250	75	88	100	113	138	163	188	213	238	263	288	313
40	36	54	23	12.5	25	37.5	50	75	100	125	150	175	200	225	250	75	88	100	113	138	163	188	213	238	263	288	313
50	51	64	25	12.5	25	37.5	50	75	100	125	150	175	200	225	250	87	100	112	125	150	175	200	225	250	275	300	325
63	51	64	25	12.5	25	37.5	50	75	100	125	150	175	200	225	250	87	100	112	125	150	175	200	225	250	275	300	325
80	56	68	30	12.5	25	37.5	50	75	100	125	150	175	200	225	250	103	116	128	141	166	191	216	241	266	291	316	341
100	56	76	32	12.5	25	37.5	50	75	100	125	150	175	200	225	250	103	116	128	141	166	191	216	241	266	291	316	341

- C85
- C85W
- C85-ST
- C85K
- C85K-ST
- C85R
- C75
- C75W
- C75-ST
- C75K
- C75K-ST
- C75R
- CP96**
- CP96K
- C96
- C96K
- C96Y
- C55
- Auto Switch
- Made to Order
- Related Products