

MODEL
CKIBXCN-HBY

Pilot-to-open check valve with standard pilot
CAPACITY: 120 gpm | CAVITY: T-19A

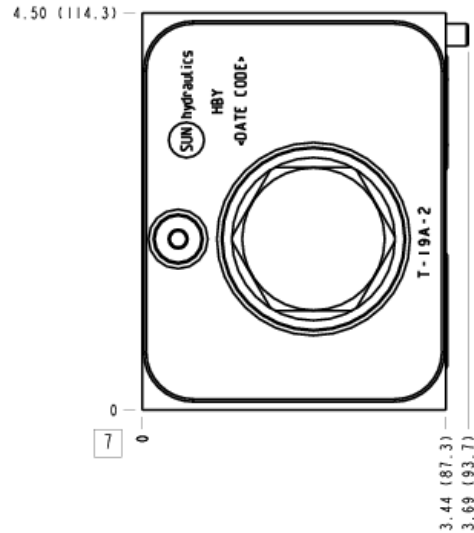
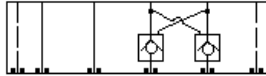
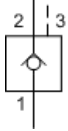

CARTRIDGE CONFIGURATION

X	Control	Standard Pilot
C	Cracking Pressure	30 psi (2 bar)
N	Seal Material	Buna-N
(none)	Material/Coating	

MANIFOLD CONFIGURATION

(none)	Modifier	6061-T651 Aluminum, Buna-N
---------------	----------	-------------------------------

NOTES

Important: Carefully consider the maximum system pressure. The pressure rating of the manifold is dependent on the manifold material, with the port type/size a secondary consideration. Manifolds constructed of aluminum are not rated for pressures higher than 3000 psi (210 bar), regardless of the port type/size specified.

This valve is a pilot to open check valve. It has a non-sealed pilot, a steel seat, and is non-vented. It allows free flow from the valve (port 2) to the load (port 1) and blocks flow in the opposite direction. Pressure at the pilot (port 3) will open the valve from port 1 to port 2. Pilot pressure needed at port 3 to open the valve is directly proportional to the load pressure at port 1. Pressure at port 2 directly opposes pilot pressure.

CARTRIDGE TECHNICAL DATA

Cavity	T-19A
Series	4
Capacity	120 gpm
Maximum Operating Pressure	5000 psi
Pilot Ratio	3:1
Maximum Valve Leakage at 110 SUS (24 cSt)	1 drops/min.
Valve Hex Size	1 5/8 in.
Valve Installation Torque	350 - 375 lbf ft
Seal kit - Cartridge	Buna: 990-019-007
Seal kit - Cartridge	EPDM: 990-019-014
Seal kit - Cartridge	Polyurethane: 990-019-002
Seal kit - Cartridge	Viton: 990-019-006
Model Weight	2.65 lb.

MANIFOLD TECHNICAL DATA

Body Type	Sandwich
Interface	ISO 08
Body Features	On A and B with cross pilot
Stack Height	3.44 in.
Open Cavities	2
Cavity	T-19A

CARTRIDGE TECHNICAL FEATURES

- Provides hose break protection, prevents loads from drifting and positively locks pressurized loads.
- Standard unsealed pilot allows air trapped in the pilot line to be purged from the circuit.
- Extremely low leakage. The seat and poppet are heat treated for long life. If the load drifts due to the valve, the seat has probably been damaged by contamination and the valve should be replaced.
- Optional external porting out of the hex end of the cartridge is available for external piloting. In this configuration, port 3 is blocked. See Control options E, and P.
- Pilot-to-open check cartridges are locking valves, not motion control valves. For motion control applications, use counterbalance valves.
- This 3 port pilot-to-open check valve and 3 port counterbalance valves are physically interchangeable (i.e. same cavities, same flow path for a given frame size). However, cartridge extension dimensions from the mounting surface may vary.
- For models with manual load release control option, turn load release clockwise to release load.
- Cartridges configured with EPDM seals are for use in systems with phosphate ester fluids. Exposure to petroleum based fluids, greases and lubricants will damage the seals.
- Corrosion resistant cartridge valves are intended for use in corrosive environments and are identified by the model code suffix /AP for external stainless steel components, or /LH for external zinc-nickel plated components. See the CONFIGURATION section for all options. For further details, please see the Materials of Construction page located under TECH RESOURCES.
- Incorporates the Sun floating style construction to minimize the possibility of internal parts binding due to excessive installation torque and/or cavity/cartridge machining variations.

ASSEMBLY FACES

FACE GRID

1	2	3	4
5	6	7	8
9	10	11	12

Face 5

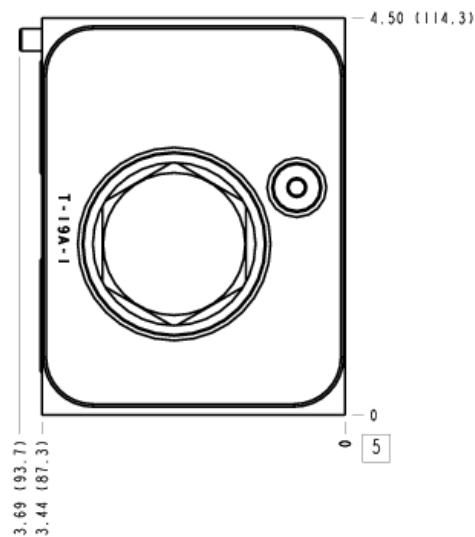

Face 6

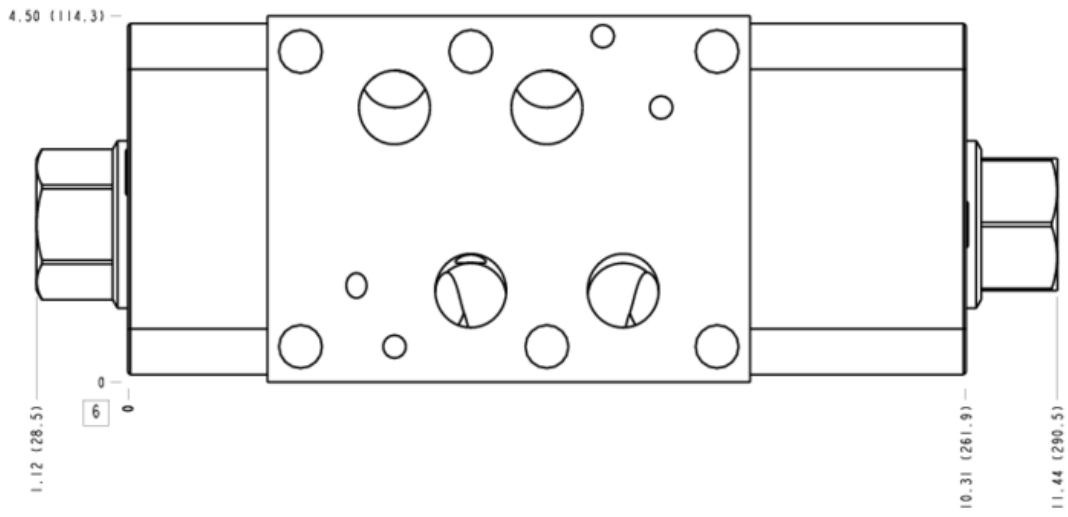

Face 7

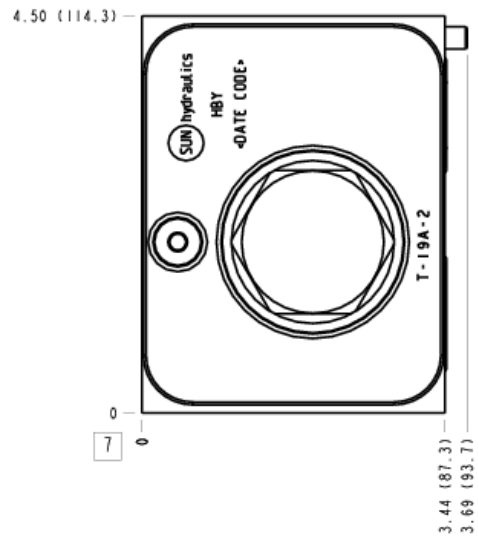

Face 8

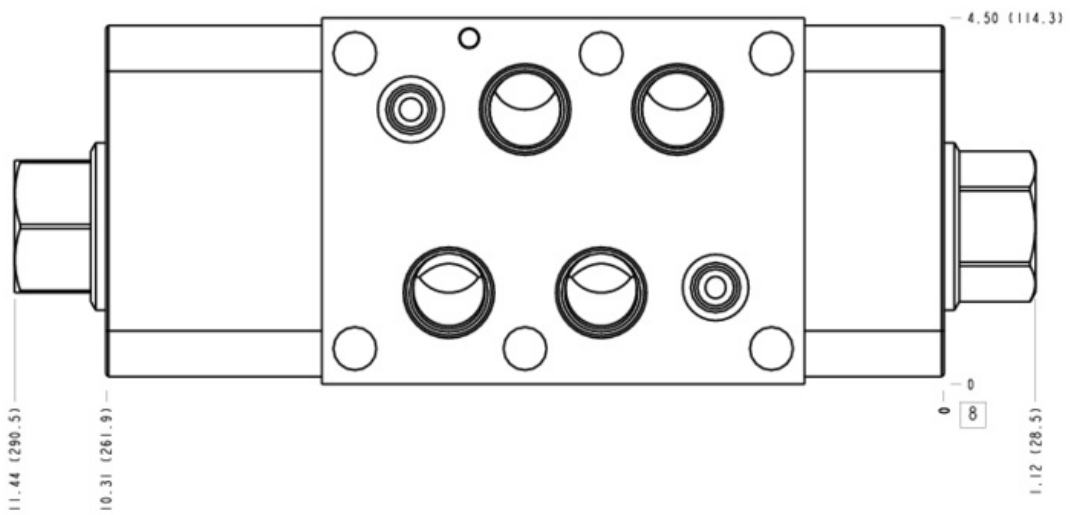

Face 10

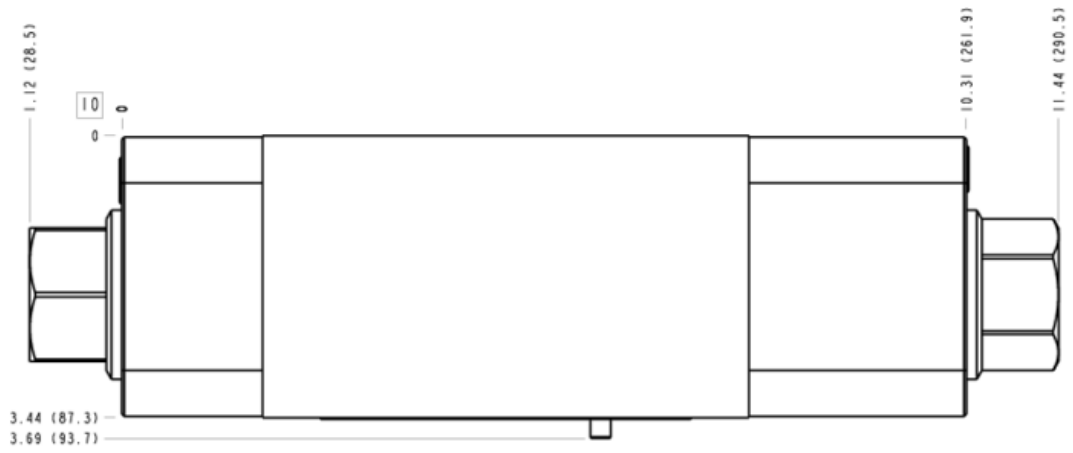

Copyright © 2002-2023 Sun Hydraulics. All rights reserved.