

## C(D)Q2, Compact Cylinder, Double Acting Single Rod, Long Stroke w/Auto Switch Mounting Groove

### CDQ2A80-200DCMZ

#### Datasheet

Following a review of our popular CQ2 compact cylinder Series our R&D engineers have totally redesigned the complete cylinder range to bring you even more performance benefits and increased cylinder options. The major difference between the new CQ2 range and the old model is the totally redesigned body, which offers improved auto-switch mounting possibilities plus an overall reduction of cylinder weight of between 5 -13% depending on the model. Now, all CQ2 cylinders from Ø 32 to 200mm are designed with slide in grooves which can accommodate auto-switches on all four cylinder sides without the need for auto-switch brackets. And, for smaller bore sizes between Ø 12 and 25mm, slide in grooves have also been integrated in the new body design to accommodate bracket free auto-switches on two surfaces. Designed for use with our simple to set, dual colour, solid state auto-switches, the integrated auto-switch channel ensures total protection against potential accidental damage and improved health and safety benefits during both installation and maintenance procedures.

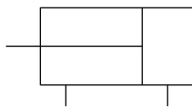

Double-acting, single-rod cylinder

### Standard specifications

Magnet	D (Built-in)
Mounting	A (Both Ends Tapped)
Bore Size	Ø80 mm
Port Thread Type	Rc
Stroke	200
Body Option	M (Rod End Male Thread)
Auto Switch	No Switch
Lead Wire or Prewired Connector	0.5 m or None in the Case of No Switch
Number	2 pcs.
Rod End Options	None
Made of Stainless Steel	None
Fluororubber Seal	None
Pressure medium	Compressed air
Maximum temperature of pressure medium with magnet	60 °C

Minimum temperature of pressure medium with magnet	-10 °C
Maximum operating pressure	1.0 MPa
Minimum operating pressure	0.05 MPa
Proof pressure	1.5 MPa
Maximum ambient temperature with magnet	60 °C
Minimum ambient temperature with magnet	-10 °C
Conform to the European RoHS Directive	Conform
Numero of pneumatic connections	2 pcs.
Pneumatic input connection	Rc 3/8
Mode of operation of drive	Double acting
Maximum piston speed	500 mm/s
Type of cushioning	Elastically
Piston rod end	Male-Thread
Geometric form of the piston rod	Single rod
Male thread of rod end	M22 x 1.5
Female thread of rod end	M16 x 2.0
Minimum piston speed	50 mm/s
Weight	3.918 Kg

## Dimensions

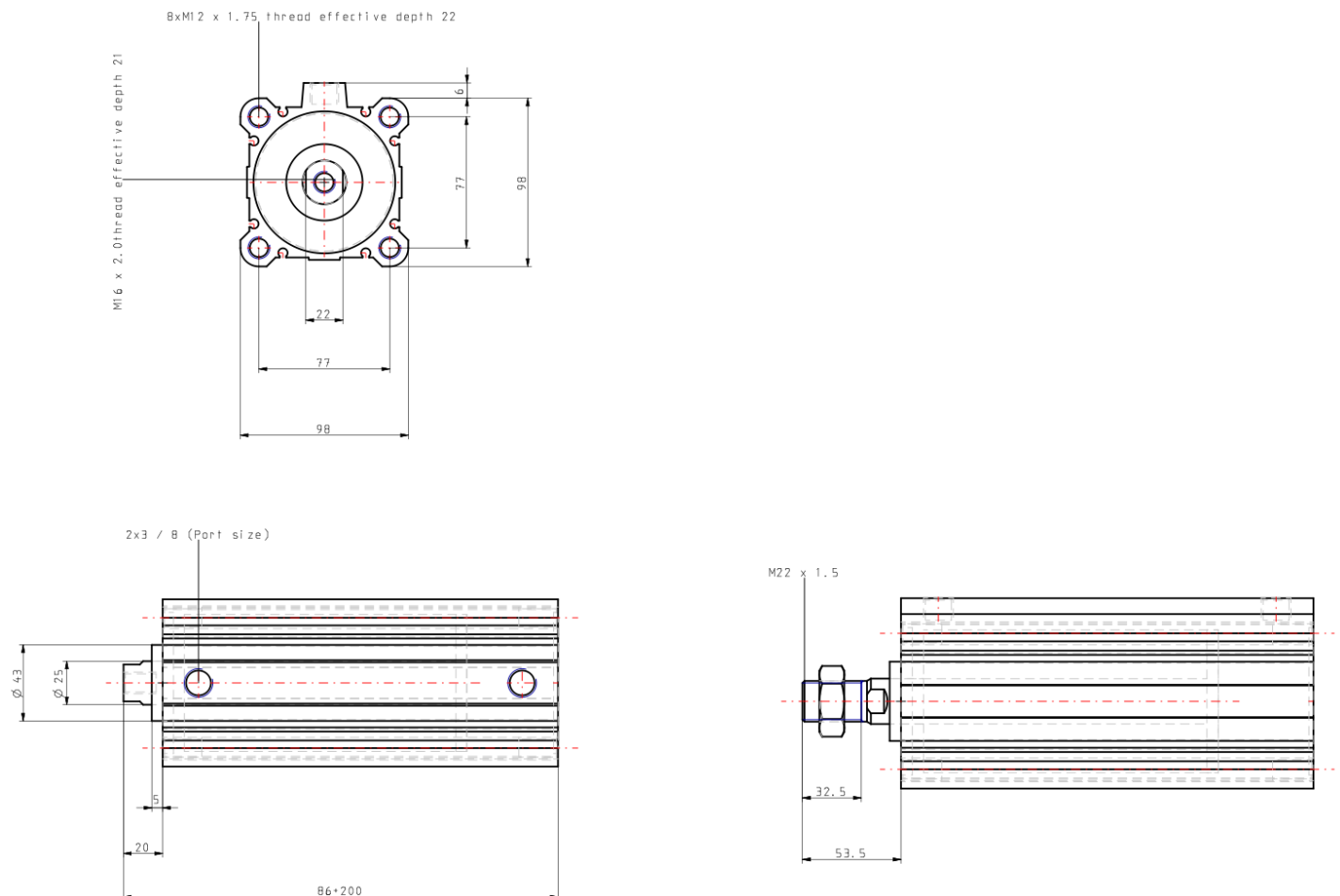

## Constructions

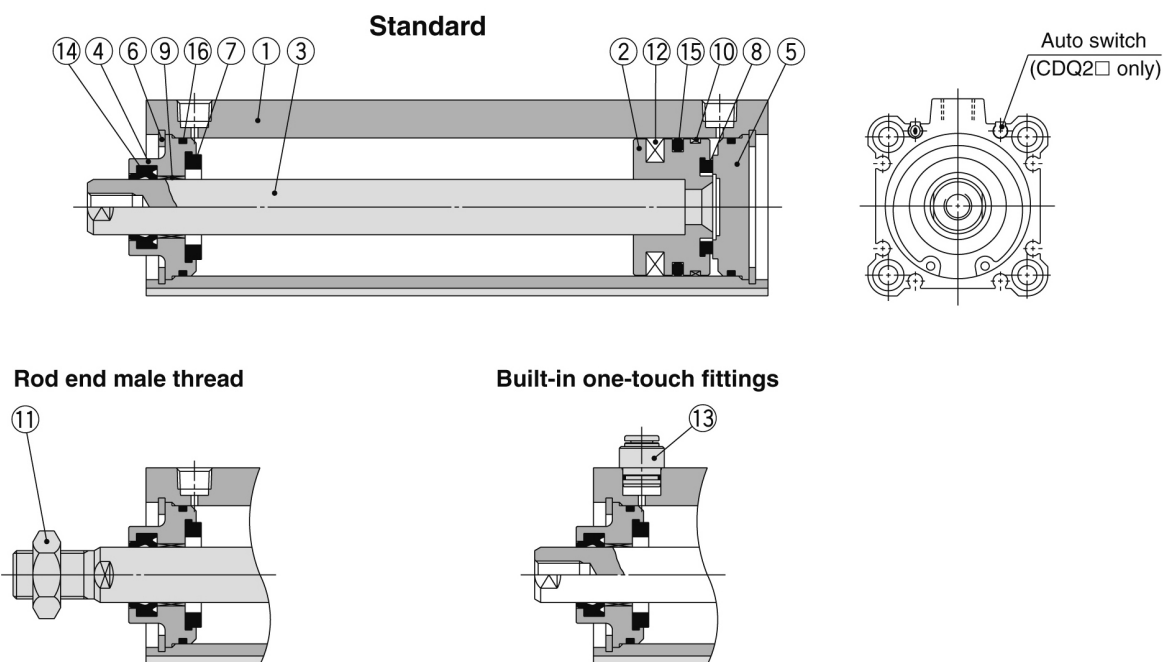

### Component Parts

No.	Description	Material	Note
1	Cylinder tube	Aluminum alloy	Hard anodised
2	Piston	Aluminum alloy	Chromated
3	Piston rod	Carbon steel	Hard chrome plated
4	Collar	Aluminum alloy	Anodised
5	Bottom plate	Aluminum alloy	Anodised
6	Retaining ring	Carbon tool steel	Phosphate coated
7	Bumper A	Urethane	
8	Bumper B	Urethane	
9	Bushing	Bearing alloy	
10	Wear ring	Resin	
11	Rod end nut	Carbon steel	Nickel plated
12	Magnet	—	For CDQ2A□ only
13	One-touch fitting	—	ø32 to ø63
14*	Rod seal	NBR	
15*	Piston seal	NBR	
16*	Tube gasket	NBR	

### Replacement Parts/Seal Kit

Bore size (mm)	Kit no.	Contents
32	CQ2A32-L-PS	Kits include items 14, 15, 16 from the table.
40	CQ2A40-L-PS	
50	CQ2A50-L-PS	
63	CQ2A63-L-PS	
80	CQ2A80-L-PS	
100	CQ2A100-L-PS	

\* Seal kit includes 14, 15, 16. Order the seal kit, based on each bore size.

\* Since the seal kit does not include a grease pack, order it separately.

**Grease pack part no.: GR-S-010 (10 g)**

## Additional information

Catalogue

[CQ2-Z-B\\_EU.pdf](#)