

Compact Cylinder

ISO Standards [ISO/21287]

New

It is possible to mount small auto switches on 4 surfaces.

Auto switches can be mounted on any of the 4 surfaces, depending on the installation conditions. Improved flexibility of system design.



2-color indication solid state auto switch

Appropriate setting of the mounting position can be performed without mistakes.

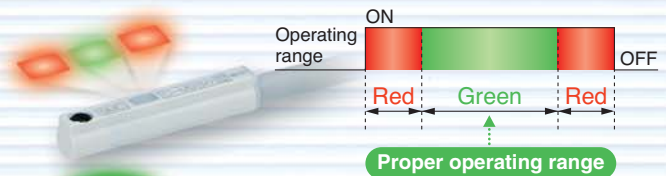

The **green** light lights up at a proper operating range.

Even if 2-color indication solid state auto switches are fixed at a proper operating range (the green light lights up), the operation may become unstable depending on the installation environment or magnetic field disturbance.

(Magnetic body, external magnetic field, proximal installation of cylinders with built-in magnet and actuators, temperature change, other factors for magnetic force fluctuation during operation, etc.)

NEW Bore sizes
ø80, ø100 added.



Series **C55**



CAT.ES20-184B

ISO Standards [ISO/21287]

Compact Cylinder

Series C55

∅20,∅25,∅32,∅40,∅50,∅63,∅80,∅100

How to Order

C55 B 20 - 10

With auto switch CD55 B 20 - 10 - M9B S

With auto switch (Built-in magnet)

Mounting style

B	Through-hole/Both ends tapped common (Standard)
L	Foot style
F	Rod side flange style
G	Head side flange style
C	Single clevis style

Bore size

20	20 mm
25	25 mm
32	32 mm
40	40 mm
50	50 mm
63	63 mm
80	80 mm
100	100 mm

Number of auto switches

Nil	2 pcs.
S	1 pc.
n	"n" pcs.

Auto switch

Nil	Without auto switch (Built-in magnet cylinder)
-----	--

* For the applicable auto switch model, refer to the table below.
* Auto switches are shipped together, (but not assembled).

Auto switch

Nil	Without auto switch (Built-in magnet cylinder)
-----	--

* For the applicable auto switch model, refer to the table below.
* Auto switches are shipped together, (but not assembled).

Rod end thread

Nil	Rod end female thread
M	Rod end male thread

Cylinder stroke (mm)

Refer to page 2 for standard and intermediate strokes.

Applicable Auto Switches/Refer to pages 16 to 21 for further information on auto switches.

Type	Special function	Electrical entry	Indicator light	Wiring (Output)	Load voltage		Auto switch model		Lead wire length (m)					Pre-wired connector	Applicable load		
					DC	AC	Perpendicular	In-line	0.5 (Nil)	1 (M)	3 (L)	5 (Z)	None (N)		IC circuit	Relay, PLC	
Solid state switch	—	Grommet	Yes	3-wire (NPN)	24 V	5 V, 12 V	—	M9NV	M9N	●	●	●	○	—	○	IC circuit	Relay, PLC
				3-wire (PNP)				M9PV	M9P	●	●	●	○	—	○		
				2-wire				M9BV	M9B	●	●	●	○	—	○		
	Diagnostic indication (2-color indication)			3-wire (NPN)				M9NWV	M9NW	●	●	●	○	—	○	IC circuit	
				3-wire (PNP)				M9PWV	M9PW	●	●	●	○	—	○		
				2-wire				M9B WV	M9B W	●	●	●	○	—	○		
				3-wire (NPN)				M9NAV	M9NA	○	○	●	○	—	○		
	Water resistant (2-color indication)			3-wire (PNP)				M9PAV	M9PA	○	○	●	○	—	○	IC circuit	
				2-wire				M9BAV	M9BA	○	○	●	○	—	○		
				2-wire (Non-polar)				—	P3DW	●	—	●	●	—	●		
Magnetic field resistant (2-color indication)	—	Grommet	Yes	3-wire (NPN equivalent)	24 V	5 V, 12 V	100 V or less	A96V	A96	●	—	●	—	—	—	IC circuit	—
	2-wire			A93V				A93	●	—	●	—	—	—	—	IC circuit	
	—			A90V				A90	●	—	●	—	—	—	—	IC circuit	

Lead wire length symbols: 0.5 m.....Nil (Example) M9NV
 1 m.....M (Example) M9NWM
 3 m.....L (Example) M9NWL
 5 m.....Z (Example) M9NWZ

* Solid state auto switches marked with "○" are produced upon receipt of order.

* There are other applicable auto switches other than the listed above. For details, refer to page 11.

* For details about auto switches with pre-wired connector, refer to pages 1328 and 1329 in Best Pneumatics No. 2. Refer to pages 20 and 21 for the D-P3DW□ type.

* Auto switches are shipped together, (but not assembled).



⚠ Caution

Be sure to read before handling.

- ① Refer to back cover for Safety Instructions and "Handling Precautions for SMC Product" (M-E03-3) for Actuators and Auto Switches Precautions.
- ② This product should not be used as a stopper.
- ③ Use the PF thread fittings for this cylinder.

Theoretical Output



Unit: N

Bore size (mm)	Operating direction	Operating pressure (MPa)		
		0.3	0.5	0.7
20	IN	71	118	165
	OUT	94	157	220
25	IN	113	189	264
	OUT	147	245	344
32	IN	181	302	422
	OUT	241	402	563
40	IN	317	528	739
	OUT	377	628	880
50	IN	495	825	1150
	OUT	589	982	1370
63	IN	841	1400	1960
	OUT	935	1560	2180
80	IN	1360	2270	3180
	OUT	1510	2520	3520
100	IN	2150	3580	5010
	OUT	2360	3930	5500

Mounting Bracket Part No.

Bore size (mm)	Foot	Flange	Single clevis
20	C55-L020	C55-F020	C55-C020
25	C55-L025	C55-F025	C55-C025
32	C55-L032	C55-F032	C55-C032
40	C55-L040	C55-F040	C55-C040
50	C55-L050	C55-F050	C55-C050
63	C55-L063	C55-F063	C55-C063
80	C55-L080	C55-F080	C55-C080
100	C55-L100	C55-F100	C55-C100

- Order two foot brackets per cylinder.
- Parts belonging to each bracket are as follows. Foot, Flange, Single clevis/Body mounting bolt

Specifications

Type	Pneumatic (Non-lube)	
Action	Double acting, Single rod	
Fluid	Air	
Proof pressure	1.5 MPa	
Maximum operating pressure	1.0 MPa	
Minimum operating pressure	0.05 MPa (ø20 to ø63), 0.03 MPa (ø80, ø100)	
Ambient and fluid temperature	Without auto switch: -10 to 70°C (No freezing) With auto switch: -10 to 60°C (No freezing)	
Cushion	Rubber bumper on both end	
Stroke length tolerance ^{Note)}	+1.0 0 mm	
Mounting	Through-hole/Both ends tapped common	
Piston speed	ø20 to ø63	50 to 500 mm/s
	ø80, ø100	50 to 300 mm/s

Note) Stroke length tolerance dose not include the amount of bumper change.

Standard Stroke

Bore size (mm)	Standard stroke (mm)
20 to 63	5, 10, 15, 20, 25, 30, 35, 40, 45, 50, 60, 80, 100, 125, 150
80, 100	10, 15, 20, 25, 30, 35, 40, 45, 50, 60, 80, 100, 125

Manufacture of Intermediate Stroke

Description	Dealing with the stroke by the 1 mm interval by using an exclusive body with the specified stroke
Part no.	Refer to "How to Order" for the standard model no. (page at left)
Stroke range	6 to 149
Example	Part no.: C55B32-47
	Makes 47 stroke tube

Weight

Without Auto Switch

Unit: g

Bore size (mm)	Cylinder stroke (mm)														
	5	10	15	20	25	30	35	40	45	50	60	80	100	125	150
20	111	124	137	150	163	176	189	202	215	228	254	306	357	422	487
25	152	168	183	199	214	230	246	261	277	292	323	386	448	526	603
32	250	273	295	317	339	362	384	406	428	451	495	584	673	785	896
40	315	339	364	388	412	436	461	485	509	533	582	679	776	897	1018
50	497	534	570	607	644	681	718	755	791	828	902	1049	1197	1381	1565
63	677	717	757	797	837	877	917	957	997	1037	1117	1277	1437	1638	1838
80	—	1164	1223	1281	1339	1398	1456	1514	1573	1631	1748	1981	2214	2506	—
100	—	2213	2295	2377	2459	2541	2623	2705	2787	2870	3034	3362	3690	4101	—

With Auto Switch (Built-in magnet)

Unit: g

Bore size (mm)	Cylinder stroke (mm)														
	5	10	15	20	25	30	35	40	45	50	60	80	100	125	150
20	113	126	139	152	165	178	191	204	216	229	255	307	359	424	489
25	154	170	185	201	217	232	248	263	279	294	325	388	450	528	606
32	254	277	299	321	343	366	388	410	432	455	499	588	677	788	900
40	319	344	368	392	416	441	465	489	513	537	586	683	780	901	1022
50	502	539	575	612	649	686	723	760	796	833	907	1054	1202	1386	1570
63	685	725	765	805	845	885	925	965	1005	1045	1125	1285	1445	1645	1845
80	—	1188	1246	1305	1363	1421	1480	1538	1596	1654	1771	2004	2238	2529	—
100	—	2248	2330	2412	2494	2577	2659	2741	2823	2905	3069	3397	3726	4136	—

Add each weight of auto switches and mounting brackets when mounting an auto switches. Refer to pages 16 to 21 for auto switch weight.

Series C55

Allowable Lateral Load

Make sure to operate strictly within the allowable lateral load range to the rod end.

Operation outside of this range may result in shorter service life or damage to the device.

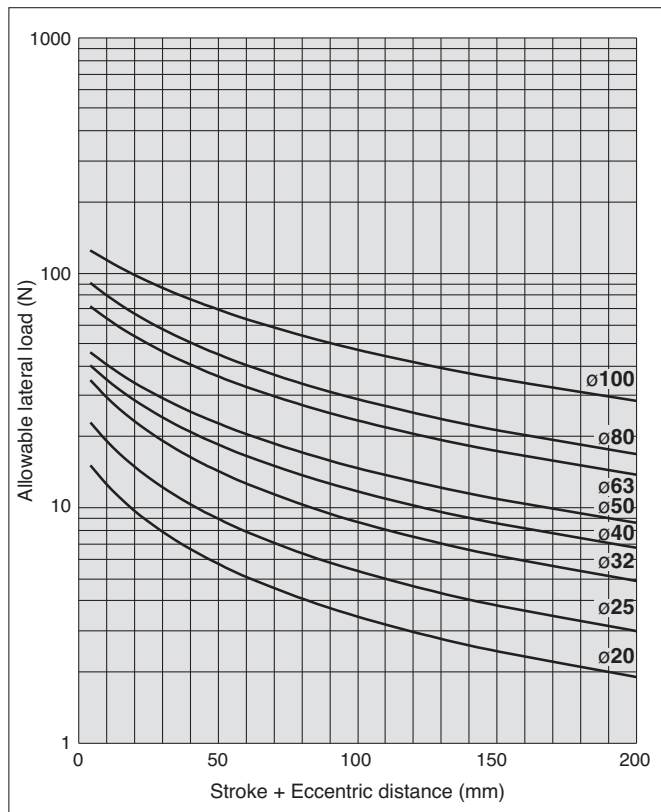
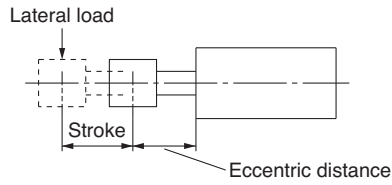

Allowable Kinetic Energy

Make sure to operate strictly within the allowable range of the load weight and maximum speed.

Operation outside of this range may cause excessive impact, which may result in the damage to the device.

Operating pressure: 1 MPa

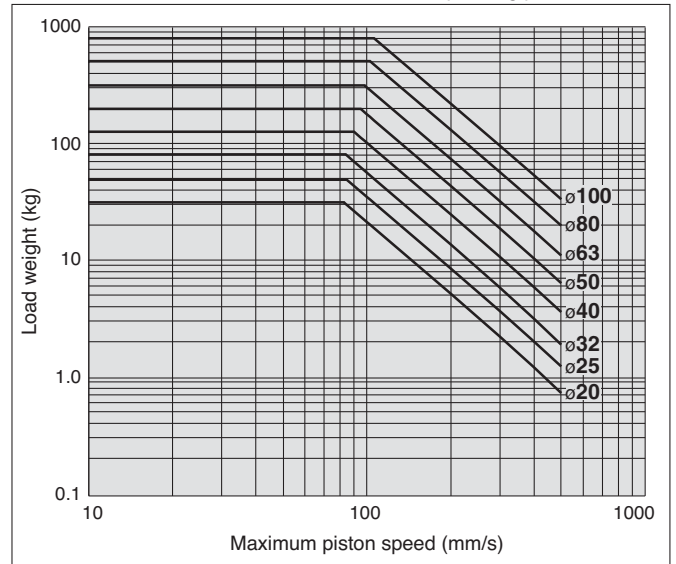

* Refer to Model Selection in Best Pneumatics No.2 for details about model selection procedure.

Construction

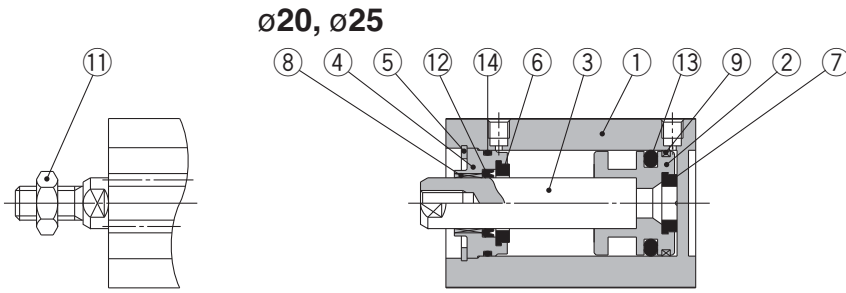

M: Rod end male thread

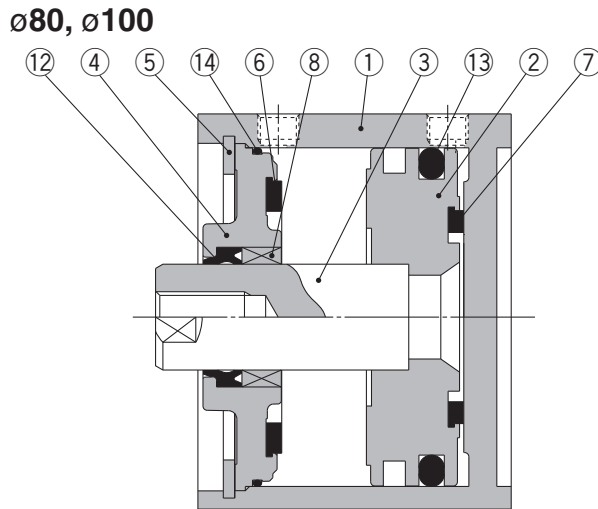
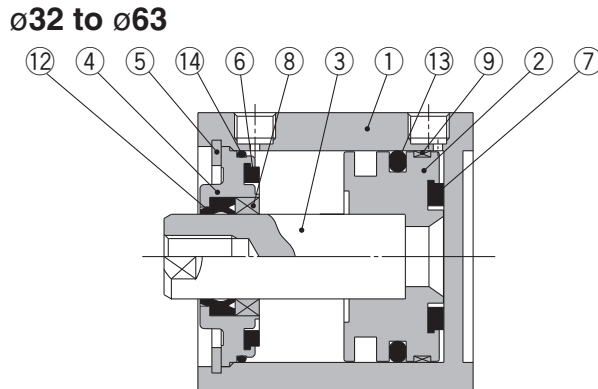

With auto switch (Built-in magnet)

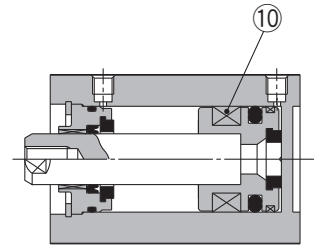

With auto switch (Built-in magnet)

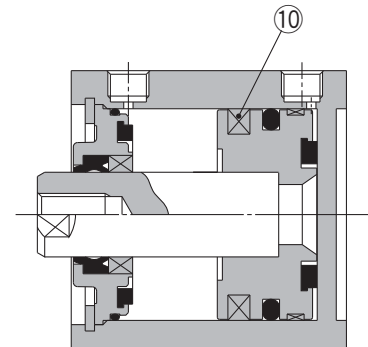

With auto switch (Built-in magnet)

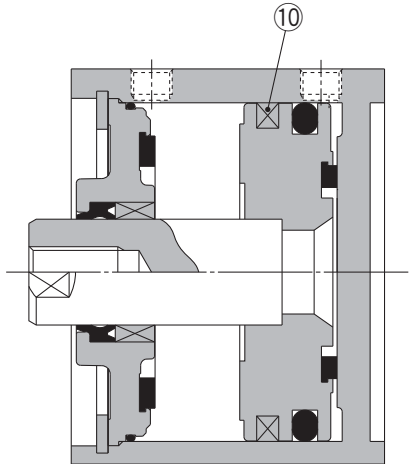

Component Parts

No.	Description	Material	Note
1	Cylinder tube	Aluminum alloy	Hard anodized
2	Piston	Aluminum alloy	Chromated
3	Piston rod	Stainless steel	$\varnothing 20, \varnothing 25$
		Carbon steel	$\varnothing 32$ to $\varnothing 100$ Hard chrome plated
4	Collar	Aluminum alloy	$\varnothing 20$ to $\varnothing 40$ Anodized
		Aluminum alloy casted	$\varnothing 50$ to $\varnothing 100$ Painted after chromated
5	Retaining ring	Carbon tool steel	Phosphate coated
6	Bumper A	Urethane	
7	Bumper B	Urethane	
8	Bushing	Bearing alloy	
9	Wear ring	Resin	$\varnothing 20$ to $\varnothing 63$
10	Magnet	—	
11	Rod end nut	Carbon steel	Nickel plated
12	Rod seal	NBR	
13	Piston seal	NBR	
14	Tube gasket	NBR	

Replacement Parts/Seal Kit

Bore size (mm)	Kit no.	Contents
20	CQ2B20-PS	Set of nos. at left (12, 13, 14)
25	CQ2B25-PS	
32	CQ2B32-PS	
40	CQ2B40-PS	
50	CQ2B50-PS	
63	CQ2B63-PS	
80	CQ2B80-PS	
100	CQ2B100-PS	

* Seal kit includes (12, 13, 14). Order the seal kit, based on each bore size.

Series C55

Mounting Bolt

Should use recommended bolt shown as below table when mounting the cylinder using through-hole.

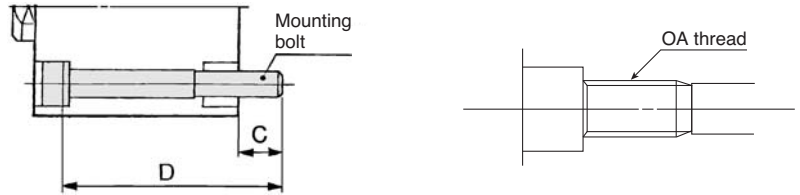

Note) To install a through-hole type mounting bolt, bore size 20 to 100 mm, make sure to use the flat washer that is provided.

Mounting Bolt for C55

Model	C	D	Mounting bolt	
C(D)55B20-5	7.2	45	M4 x 45 ℓ	
-10		50	x 50 ℓ	
-15		55	x 55 ℓ	
-20		60	x 60 ℓ	
-25		65	x 65 ℓ	
-30		70	x 70 ℓ	
-35		75	x 75 ℓ	
-40		80	x 80 ℓ	
-45		85	x 85 ℓ	
-50		90	x 90 ℓ	
-60				
-80		Fix the cylinder by using the OA thread that are provided with the cylinder tube.		
-100				
-125				
-150				
C(D)55B25-5	10.2	50	M4 x 50 ℓ	
-10		55	x 55 ℓ	
-15		60	x 60 ℓ	
-20		65	x 65 ℓ	
-25		70	x 70 ℓ	
-30		75	x 75 ℓ	
-35		80	x 80 ℓ	
-40		85	x 85 ℓ	
-45		90	x 90 ℓ	
-50		95	x 95 ℓ	
-60				
-80		Fix the cylinder by using the OA thread that are provided with the cylinder tube.		
-100				
-125				
-150				
C(D)55B32-5	10	55	M5 x 55 ℓ	
-10		60	x 60 ℓ	
-15		65	x 65 ℓ	
-20		70	x 70 ℓ	
-25		75	x 75 ℓ	
-30		80	x 80 ℓ	
-35		85	x 85 ℓ	
-40		90	x 90 ℓ	
-45		95	x 95 ℓ	
-50		100	x 100 ℓ	
-60		110	x 110 ℓ	
-80		130	x 130 ℓ	
-100	150	x 150 ℓ		
-125	Fix the cylinder by using the OA thread that are provided with the cylinder tube.			
-150				

Model	C	D	Mounting bolt
C(D)55B40-5	9	55	M5 x 55 ℓ
-10		60	x 60 ℓ
-15		65	x 65 ℓ
-20		70	x 70 ℓ
-25		75	x 75 ℓ
-30		80	x 80 ℓ
-35		85	x 85 ℓ
-40		90	x 90 ℓ
-45		95	x 95 ℓ
-50		100	x 100 ℓ
-60		110	x 110 ℓ
-80		130	x 130 ℓ
-100	150	x 150 ℓ	
-125	Fix the cylinder by using the OA thread that are provided with the cylinder tube.		
-150			
C(D)55B50-5	8.4	55	M6 x 55 ℓ
-10		60	x 60 ℓ
-15		65	x 65 ℓ
-20		70	x 70 ℓ
-25		75	x 75 ℓ
-30		80	x 80 ℓ
-35		85	x 85 ℓ
-40		90	x 90 ℓ
-45		95	x 95 ℓ
-50		100	x 100 ℓ
-60		110	x 110 ℓ
-80		130	x 130 ℓ
-100	150	x 150 ℓ	
-125	Fix the cylinder by using the OA thread that are provided with the cylinder tube.		
-150			
C(D)55B63-5	9.4	60	M6 x 60 ℓ
-10		65	x 65 ℓ
-15		70	x 70 ℓ
-20		75	x 75 ℓ
-25		80	x 80 ℓ
-30		85	x 85 ℓ
-35		90	x 90 ℓ
-40		95	x 95 ℓ
-45		100	x 100 ℓ
-50		105	x 105 ℓ
-60		115	x 115 ℓ
-80		135	x 135 ℓ
-100	155	x 155 ℓ	
-125	Fix the cylinder by using the OA thread that are provided with the cylinder tube.		
-150			

Model	C	D	Mounting bolt
C(D)55B80-10	11	70	M8 x 70 ℓ
-15		75	x 75 ℓ
-20		80	x 80 ℓ
-25		85	x 85 ℓ
-30		90	x 90 ℓ
-35		95	x 95 ℓ
-40		100	x 100 ℓ
-45		105	x 105 ℓ
-50		110	x 110 ℓ
-60		120	x 120 ℓ
-80		140	x 140 ℓ
-100		160	x 160 ℓ
-125	Fix the cylinder by using the OA thread that are provided with the cylinder tube.		
C(D)55B100-10	13	85	M8 x 85 ℓ
-15		90	x 90 ℓ
-20		95	x 95 ℓ
-25		100	x 100 ℓ
-30		105	x 105 ℓ
-35		110	x 110 ℓ
-40		115	x 115 ℓ
-45		120	x 120 ℓ
-50		125	x 125 ℓ
-60		135	x 135 ℓ
-80		155	x 155 ℓ
-100		175	x 175 ℓ
-125	Fix the cylinder by using the OA thread that are provided with the cylinder tube.		

Dimensions

[First angle projection]

ø20, ø25

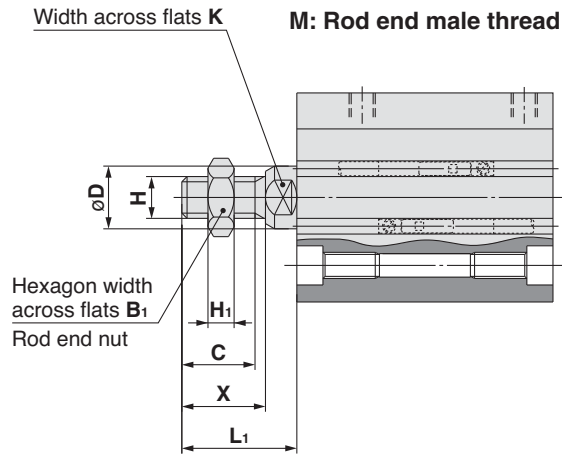
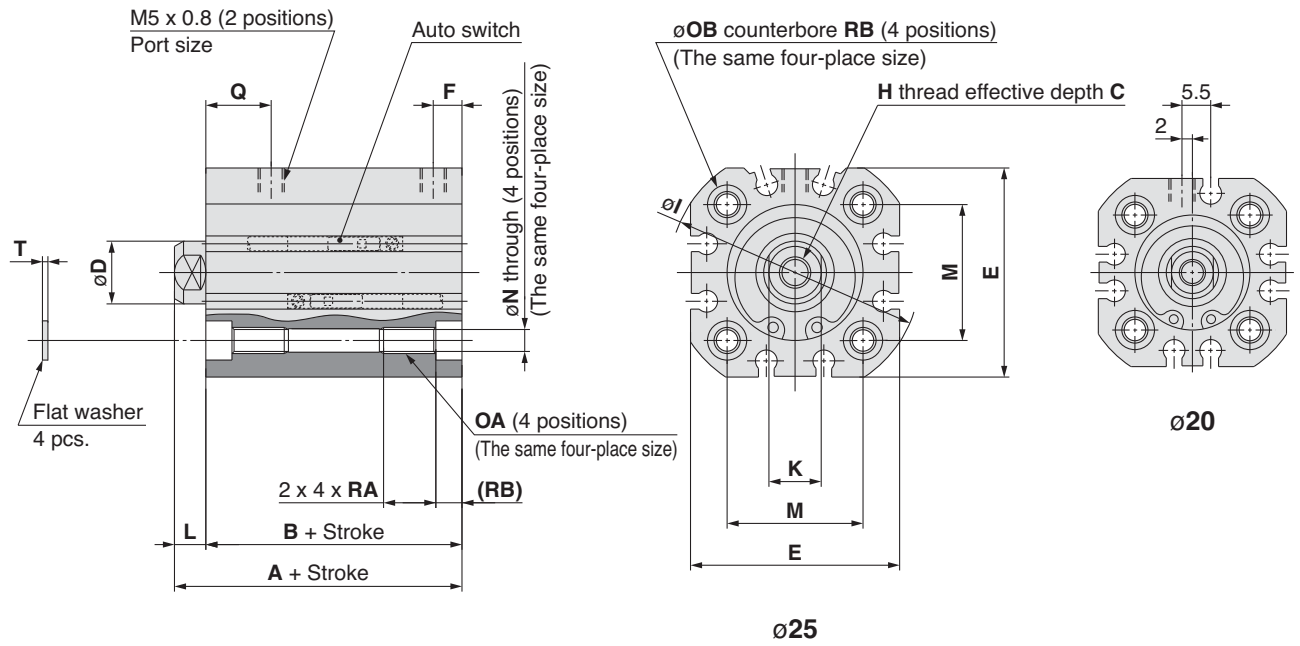

Rod End Male Thread (mm)

Bore size (mm)	B ₁	C	D	H	H ₁	K	L ₁	X
20	13	14	10	M8 x 1.25	5	8	22	16
25	13	14	12	M8 x 1.25	5	10	22	16

Basic Style

(mm)

Bore size (mm)	A	B	C	D	E	F	H	I	K	L	M	N	OA	OB	Q	RA	RB	T
20	43	37	10	10	36	5.5	M6 x 1.0	43	8	6	22	4.5	M5 x 0.8	7.5	13	10	5	0.8
25	45	39	10	12	40	5.5	M6 x 1.0	48	10	6	26	4.5	M5 x 0.8	7.5	13	10	5	0.8

Series C55

Dimensions

[First angle projection]

ø32 to ø63

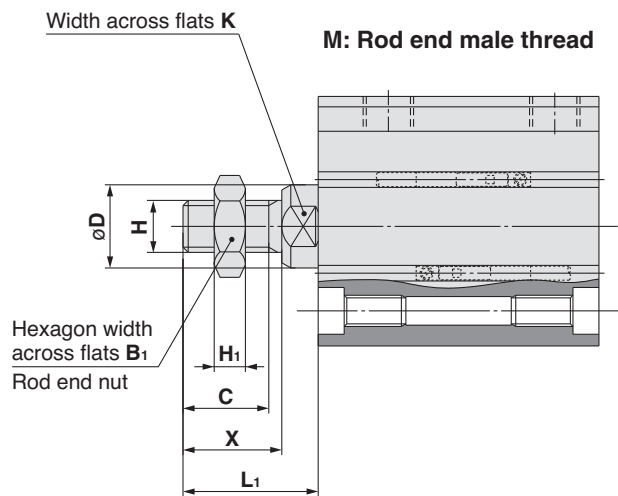
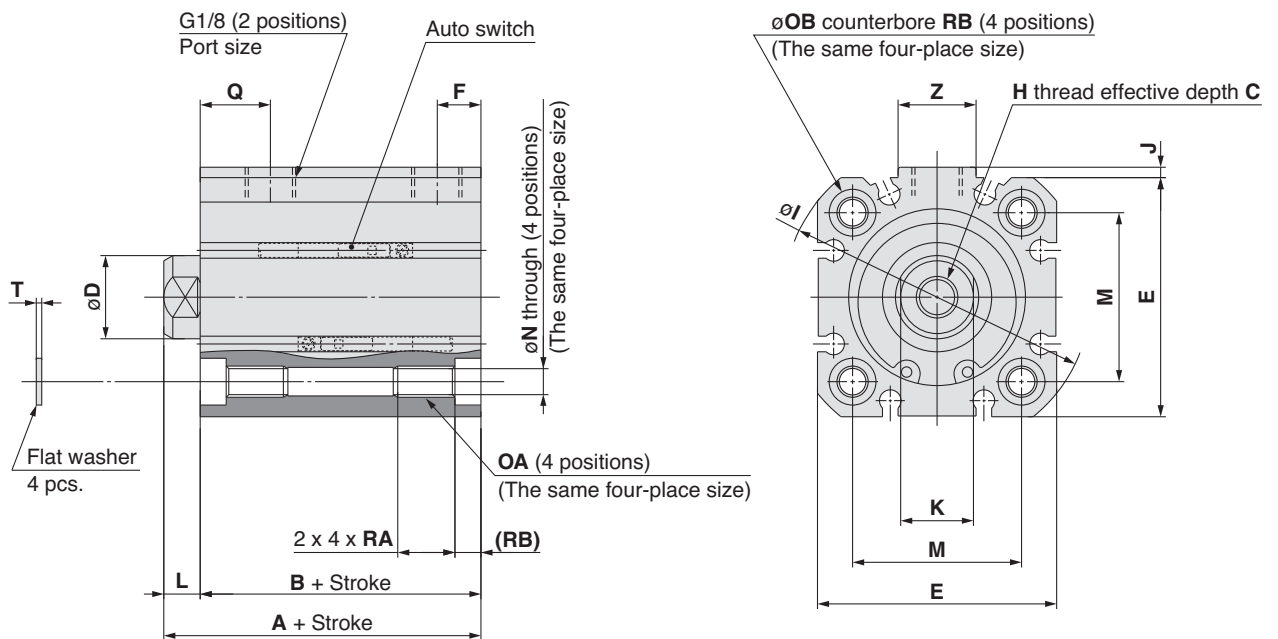

Rod End Male Thread

(mm)

Bore size (mm)	B_1	C	D	H	H_1	K	L_1	X
32	17	16.5	16	M10 x 1.25	6	14	26	19
40	17	16.5	16	M10 x 1.25	6	14	26	19
50	19	19.5	20	M12 x 1.25	7	17	30	22
63	19	19.5	20	M12 x 1.25	7	17	30	22

Basic Style

(mm)

Bore size (mm)	A	B	C	D	E	F	H	I	J	K	L	M	N	OA	OB	Q	RA	RB	T	Z
32	51	44	12	16	46	8.5	M8 x 1.25	59	2	14	7	32.5	5.5	M6 x 1.0	9	14.5	11	5	1	15
40	52	45	12	16	52	9.5	M8 x 1.25	67	3	14	7	38	5.5	M6 x 1.0	9	14.5	11	5	1	17
50	53	45	16	20	64	10.5	M10 x 1.5	82	2	17	8	46.5	6.6	M8 x 1.25	10.5	13.5	15	5	1.6	17
63	57	49	16	20	74	14.5	M10 x 1.5	96	3	17	8	56.5	6.6	M8 x 1.25	10.5	15.5	15	5	1.6	17

Dimensions

[First angle projection]

ø80, ø100

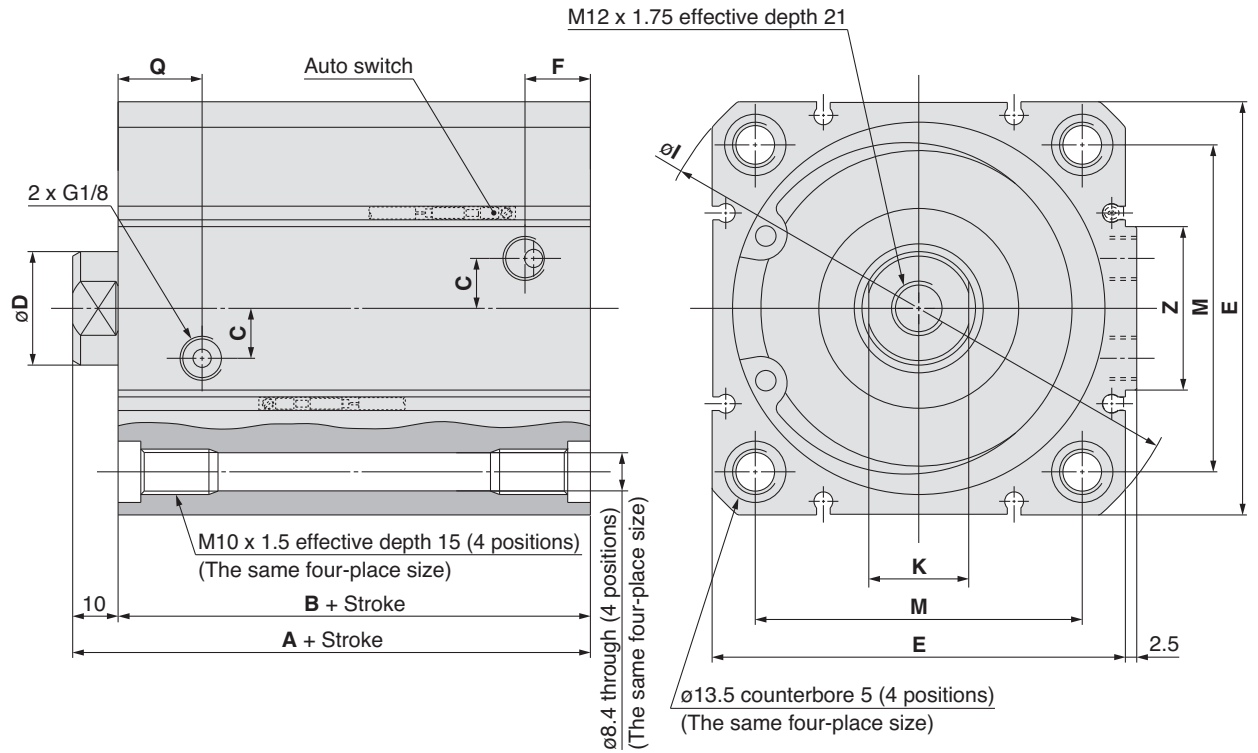

M: Rod end male thread

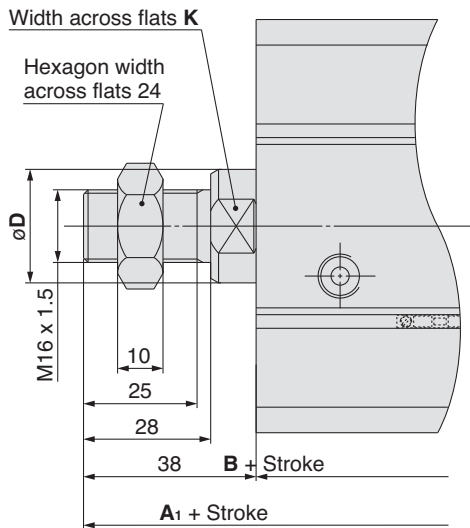

Basic Style

(mm)

Bore size (mm)	A	B	C	D	E	F	I	K	M	Q	Z
80	64	54	11	25	91	15	121	22	72	19	36
100	77	67	14	30	111	18	145	27	89	26	42

Rod End Male Thread (mm)

Bore size (mm)	A ₁
80	92
100	106.5

Mounting Bracket

[First angle projection]

Foot bracket

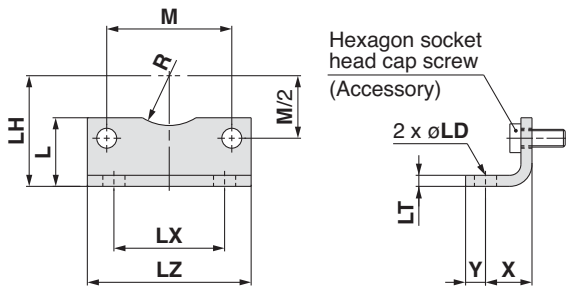

(mm)

Bore size (mm)	L	LD	LH	LT	LX	LZ	M	R	X	Y	Hexagon socket head cap screw
20	22	7	27	4	22	36	22	8	16	7	M5
25	22	7	29	4	26	40	26	10	16	7	M5
32	24.5	7	33.5	4	32	46	32.5	15	16	7	M6
40	26	10	38	4	36	52	38	17.5	18	9	M6
50	31	10	45	5	45	64	46.5	20	21	9	M8
63	31	10	50	5	50	74	56.5	22.5	21	9	M8
80	38.5	12	63	6	63	96	72	—	26	11	M10
100	45	14.5	74	6	75	116	89	—	27	13	M10

Flange bracket

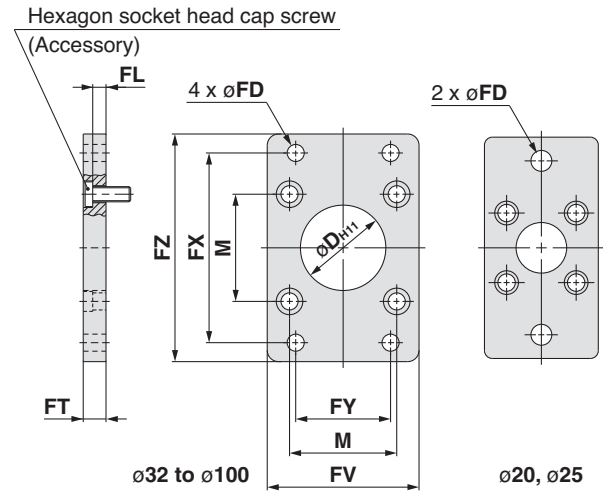

(mm)

Bore size (mm)	D	M	FD	FL	FT	FV	FX	FY	FZ	Hexagon socket head cap screw
20	16	22	6.6	2.8	8	38	55	—	68	M5
25	16	26	6.6	2.8	8	38	60	—	73	M5
32	30	32.5	7	5	10	50	64	32	79	M6
40	35	38	9	5	10	55	72	36	90	M6
50	40	46.5	9	6	12	70	90	45	110	M8
63	45	56.5	9	6	12	80	100	50	120	M8
80	45	72	12	8	16	100	126	63	153	M10
100	55	89	14	8	16	120	150	75	178	M10

Single clevis bracket

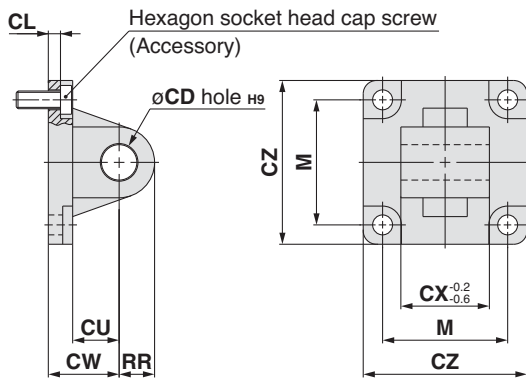

(mm)

Bore size (mm)	CD _{H9}	CL	CU	CW	CX	CZ	M	RR	Hexagon socket head cap screw
20	8	3	12	20	16	35	22	9	M5
25	8	3	12	20	16	40	26	9	M5
32	10	5.5	12	22	26	45	32.5	9.5	M6
40	12	5.5	15	25	28	51	38	12	M6
50	12	6.5	15	27	32	64	46.5	12	M8
63	16	6.5	20	32	40	74	56.5	16	M8
80	16	10	20	36	50	94	72	16	M10
100	20	10	25	41	60	113	89	20	M10

Proper Auto Switch Mounting Position (Detection at Stroke End) and Its Mounting Height [First angle projection]

Reed auto switch
D-A9□

Solid state auto switch
D-M9□
D-M9□W
D-M9□AL
D-P3DW□

∅20, ∅25

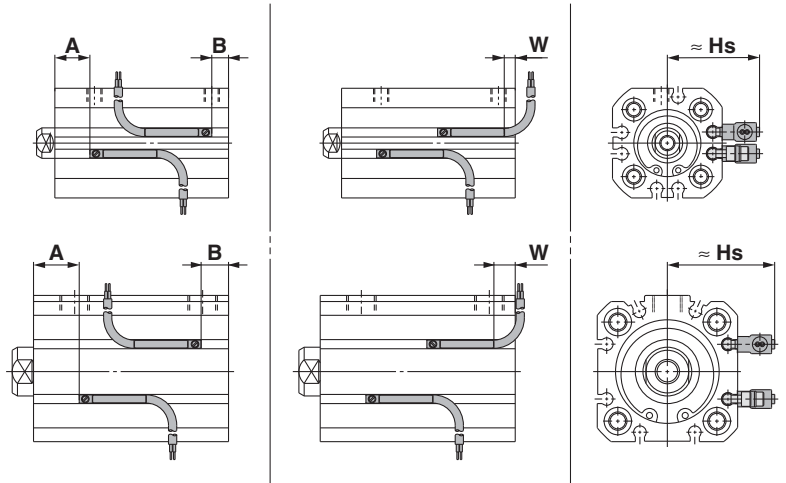

∅32, ∅40, ∅50, ∅63, ∅80, ∅100

* Figures in the table below are used as a reference when mounting the auto switches for stroke end detection. In the case of actually setting the auto switches, adjust them after confirming their operation.

Auto switch model Bore size (mm)	D-A9□			D-M9□ D-M9□W			D-M9□AL			D-P3DW□			
	A	B	W	A	B	W	A	B	W	A	B	W	Hs
20	11.5	5.5	1 (3.5)	15.5	9.5	-0.5	15.5	9.5	-2.5	6.0	0.5	-3.0	30
25	12.5	7.5	3 (5.5)	16.5	11.5	1.5	16.5	11.5	-0.5	7	2.5	-1	32
32	14.5	9.5	5 (7.5)	18.5	13.5	3.5	18.5	13.5	1.5	9.5	4	1	35
40	13	12	7.5 (10)	17	16	6	17	16	4	8	7	3.5	38
50	9.5	15.5	11 (13.5)	13.5	19.5	9.5	13.5	19.5	7.5	4.5	10.5	7	44
63	10.5	18.5	14 (16.5)	14.5	22.5	12.5	14.5	22.5	10.5	5.5	13.5	10	49
80	16.5	17.5	13 (15.5)	20.5	21.5	11.5	20.5	21.5	9.5	11.5	12.5	9	57.5
100	24.5	22.5	18 (20.5)	28.5	26.5	16.5	28.5	26.5	14.5	19.5	17.5	14	67.5

The dimension inside () is for D-A96.

Negative figures in the table W indicate an auto switch is mounted outward from the edge of the cylinder body.

Reed auto switch
D-A9□V

Solid state auto switch
D-M9□V
D-M9□WV
D-M9□AVL

∅20, ∅25

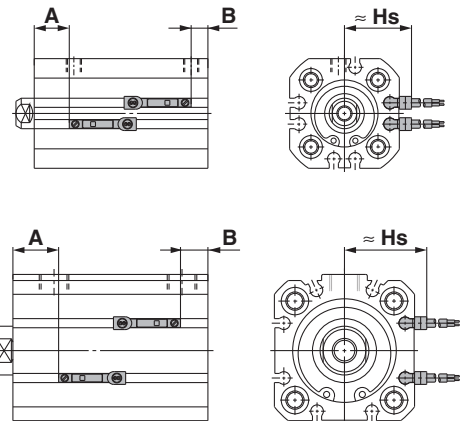

∅32, ∅40, ∅50, ∅63, ∅80, ∅100

* Figures in the table below are used as a reference when mounting the auto switches for stroke end detection. In the case of actually setting the auto switches, adjust them after confirming their operation.

Auto switch model Bore size (mm)	D-A9□V			D-M9□V D-M9□WV D-M9□AVL		
	A	B	Hs	A	B	Hs
20	11.5	5.5	22	15.5	9.5	24
25	12.5	7.5	24	16.5	11.5	26
32	14.5	9.5	27	18.5	13.5	29
40	13	12	30	17	16	32
50	9.5	15.5	36	13.5	19.5	38
63	10.5	18.5	41	14.5	22.5	43
80	16.5	17.5	49.5	20.5	21.5	52
100	24.5	22.5	60	28.5	26.5	62

Series C55

The Number of Surfaces and Grooves Where an Auto Switch Can Be Mounted (As Direct Mounting)

The number of the surfaces and grooves where the auto switch can be mounted, by switch type, are shown in the table below.

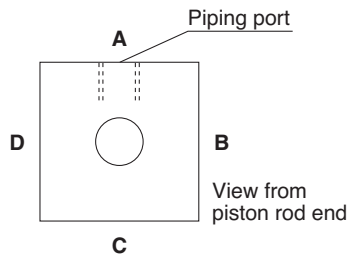

Mounting the D-P3DW□ on a $\phi 20$ to $\phi 25$ port surface interferes with the fitting, so it needs to be mounted on a place other than the port surface.

For $\phi 32$ to $\phi 100$, if the corner of the fitting hexagon interferes with the D-P3DW□ Series, adjust the tightening of the fitting to eliminate the interference.

Also, in the case of interference with an elbow type fitting, direct the port of the fitting away from the D-P3DW□ Series.

If you have any other questions, please contact SMC.

Auto switch model	D-A9□, M9□				D-P3DW□			
	A (Mounting groove no.)	B (Mounting groove no.)	C (Mounting groove no.)	D (Mounting groove no.)	A (Mounting groove no.)	B (Mounting groove no.)	C (Mounting groove no.)	D (Mounting groove no.)
20	○ (1)	○ (2)	○ (2)	○ (2)	×	○ (2)	○ (2)	○ (2)
25	○ (2)	○ (2)	○ (2)	○ (2)	×	○ (2)	○ (2)	○ (2)
32	○ (2)	○ (2)	○ (2)	○ (2)	×	○ (2)	○ (2)	○ (2)
40	○ (2)	○ (2)	○ (2)	○ (2)	×	○ (2)	○ (2)	○ (2)
50	○ (2)	○ (2)	○ (2)	○ (2)	×	○ (2)	○ (2)	○ (2)
63	○ (2)	○ (2)	○ (2)	○ (2)	×	○ (2)	○ (2)	○ (2)
80	○ (2)	○ (2)	○ (2)	○ (2)	○ (2)	○ (2)	○ (2)	○ (2)
100	○ (2)	○ (2)	○ (2)	○ (2)	○ (2)	○ (2)	○ (2)	○ (2)

Operating Range

Auto switch model	Bore size (mm)							
	20	25	32	40	50	63	80	100
D-A9□(V)	9	9	9	9	9	10.5	14	10.5
D-M9□(V) D-M9□W(V) D-M9□A(V)	5	4.5	5	4	4.5	5	10	8
D-P3DW□	5	5.5	5.5	5.5	5.5	6.5	9	7

* The operating ranges are provided as guidelines including hystereses and are not guaranteed values (assuming approximately $\pm 30\%$ variations). They may vary significantly with ambient environments.

Minimum Auto Switch Mounting Stroke

Bore size (mm)	Auto switch model No. of auto switch mounted	(mm)							
		D-A9□	D-A9□V	D-M9□	D-M9□W D-M9□A	D-M9□V	D-M9□WV	D-M9□AV	D-P3DW□
20	2 pcs.	10	10	15	15	5	10	10	15
	1 pc.	10	5	15	15	5	5	10	15
25	2 pcs.	10	10	10	15	5	10	10	15
	1 pc.	10	5	10	15	5	5	10	15
32, 40, 50	2 pcs.	10	10	10	15	5	10	10	10
	1 pc.	10	5	10	15	5	5	10	10
63	2 pcs.	10	10	10	15	5	10	10	10
	1 pc.	5	5	5	15	5	5	10	10
80, 100	2 pcs.	10	10	15	15	5	10	10	10
	1 pc.	10	5	15	15	5	5	10	10

Besides the models listed in "How to Order," the following auto switches are applicable.

* Normally closed (NC = b contact), solid state auto switch (D-F9G/F9H type, and D-F8 type) are also available. For details, refer to Best Pneumatics No.2.

* For solid state auto switches, auto switches with a pre-wired connector are also available. Refer to Best Pneumatics No.2 for details.

Mounting of Auto Switch/Direct Mounting Style

To mount auto switches, follow the instruction illustrated below.

<Applicable auto switch>

Solid state.....D-M9□(V)
 D-M9□W(V)
 D-M9□A(V)
 Reed.....D-A□(V)

∅20 to ∅100

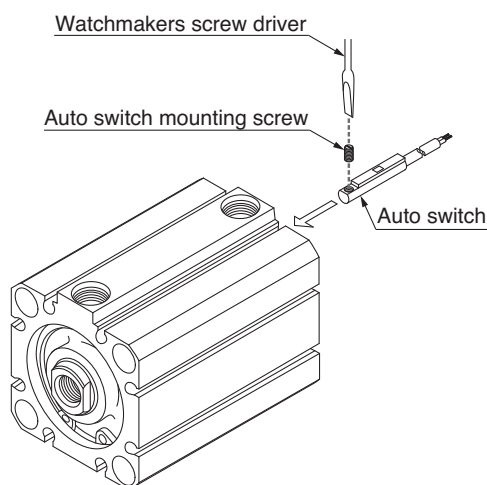

Use a watchmakers screwdriver with a handle 5 to 6 mm in diameter when tightening the auto switch mounting screw.

Tightening Torque of Auto Switch Mounting Screws

Auto switch model	Tightening torque (N·m)
D-M9□(V) D-M9□W(V) D-M9□A(V)L	0.05 to 0.15
D-A9□(V)	0.10 to 0.20

<Applicable auto switch>

Solid state.....D-P3DW□

∅20 to ∅100

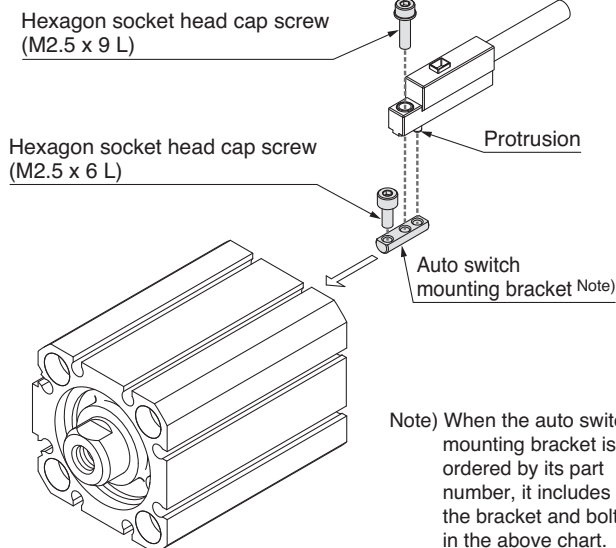

Note) When the auto switch mounting bracket is ordered by its part number, it includes all the bracket and bolts in the above chart.

Applicable auto switch	Auto switch mounting bracket part no.
D-P3DW□	BQ3-032S

- ① Insert the protrusion on the bottom of the auto switch into the mating part of the auto switch mounting bracket and fix the auto switch and the auto switch mounting bracket temporarily by tightening the hexagon socket head cap screw (M2.5 x 9 L) 1 to 2 turns.
- ② Insert the temporarily tightened mounting bracket into the mating groove of the cylinder/actuator, and slide the auto switch onto the cylinder/actuator through the groove.
- ③ Check the detecting position of the auto switch and fix the auto switch firmly with the hexagon socket head cap screw (M2.5 x 6 L, M2.5 x 9 L).*
- ④ If the detecting position is changed, go back to step ②.

* The hexagon socket head cap screw (M2.5 x 6 L) is used to fix the mounting bracket and cylinder/actuator. This enables the replacement of the auto switch without adjusting the auto switch position.

Note 1) Ensure that the auto switch is covered with the mating groove to protect the auto switch.

Note 2) The torque for tightening the hexagon socket head cap screw (M2.5 x 6 L, M2.5 x 9 L) is 0.2 to 0.3 N·m.

Note 3) Tighten the hexagon socket head cap screws evenly.

Note 4) For ∅80 or ∅100, in the case of mounting the auto switch of the D-P3DW□ Series onto the port surface, if the corner of the fitting hexagon interferes with the auto switch, adjust the tightening of the fitting to eliminate the interference. In the case of interference with an elbow type fitting, direct the port of the fitting away from the auto switch. Such interference must be avoided especially when selecting a speed controller with fittings or speed exhaust controller, etc.

Note 5) When the cylinder with auto switches is ordered, the body of the cylinder/auto switch and auto switch mounting bracket are shipped together.

Prior to Use

Auto Switches Common Specifications 1

⚠ Specific Product Precautions

Before handling auto switches, refer to “Handling Precautions for SMC Products” (M-E03-3) for Auto Switches Precautions.

Auto Switches Common Specifications

Type	Reed auto switch	Solid state auto switch
Operating time	1.2 ms	1 ms or less *
Impact resistance	300 m/s ²	1000 m/s ²
Insulation resistance	50 MΩ or more at 500 VDC Mega (Between lead wire and case)	
Withstand voltage	1500 VAC for 1 minute (Between lead wire and case)	1000 VAC for 1 minute (Between lead wire and case)
Ambient temperature	-10 to 60°C	
Enclosure	IEC60529 Standard IP67	

* The operating time for the D-P3DW□ is 40 ms or less.

Lead Wire

Lead wire length indication
(Example)

D-M9BW **L**

● Lead wire length

Nil	0.5 m
M	1 m
L	3 m
Z	5 m

Note 1) Lead wire length Z: 5 m

Applicable auto switches

Solid state auto switch: Manufactured upon receipt of order as standard.

Note 2) The standard lead wire length for water resistant 2-color indication solid state auto switches is 3 m.

(D-M9□A(V)L can be used with a lead wire of 0.5 m and 3 m.)

Note 3) 1 m (M): D-M9□(V), M9□W(V), M9□A(V)L only.

Note 4) Lead wire length tolerance

Lead wire length	Tolerance
0.5 m	±15 mm
1 m	±30 mm
3 m	±90 mm
5 m	±150 mm

Prior to Use

Auto Switches Common Specifications 2

⚠ Specific Product Precautions

Before handling auto switches, refer to “Handling Precautions for SMC Products” (M-E03-3) for Auto Switches Precautions.

Auto Switch Hysteresis

Hysteresis is the distance between the position at which piston movement operates an auto switch to the position at which reverse movement turns the switch off. This hysteresis is included in part of the operating range (one side).

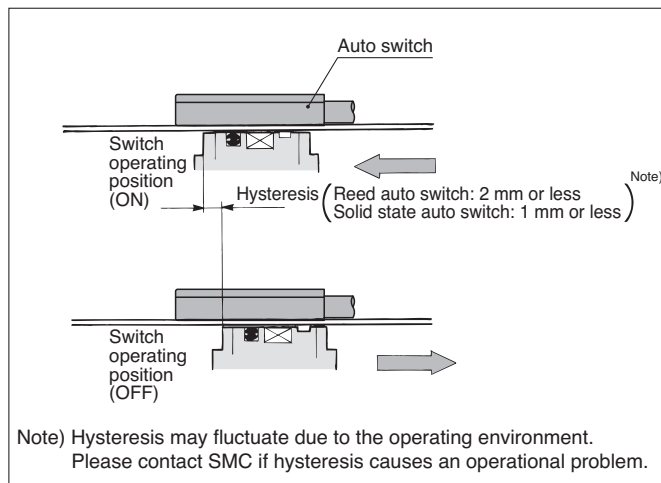

Contact Protection Box: CD-P11, CD-P12

<Applicable switch models>

D-A9/A9□V

The auto switches above do not have a built-in contact protection circuit. A contact protection box is not required for solid state auto switches due to their construction.

- ① Where the operation load is an inductive load.
- ② Where the wiring length to load is greater than 5 m.
- ③ Where the load voltage is 100 VAC.

Therefore, use a contact protection box with the switch for any of the above cases:

The contact life may be shortened (due to permanent energizing conditions.)

When the load voltage is increased by more than 10% to the rating of applicable auto switches above, use a contact protection box (CD-P11) to reduce the upper limit of the load current by 10% so that it can be set within the range of the load current range, 110 VAC.

Contact Protection Box Specifications

Part no.	CD-P11	CD-P12
Load voltage	100 VAC or less	200 VAC
Max. load current	25 mA	12.5 mA

* Lead wire length — Auto switch connection side 0.5 m
Load connection side 0.5 m



Contact Protection Box Internal Circuit

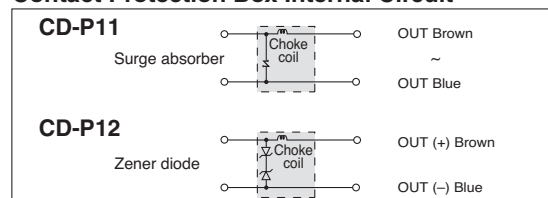

Contact Protection Box/Dimensions



Contact Protection Box Connection

To connect a switch unit to a contact protection box, connect the lead wire from the side of the contact protection box marked SWITCH to the lead wire coming out of the switch unit. Keep the switch as close as possible to the contact protection box, with a lead wire length of no more than 1 meter.

Prior to Use

Auto Switches Connection and Example

Basic Wiring

Solid state 3-wire, NPN

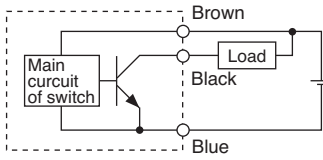

(Power supply for switch and load are separate)

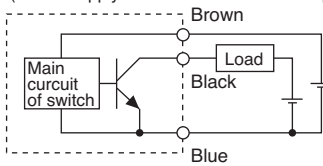

Solid state 3-wire, PNP

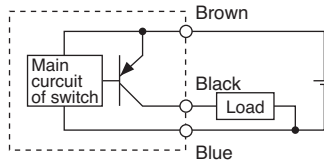

2-wire (Solid state)

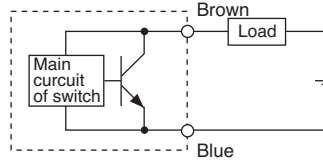

2-wire (Reed switch)

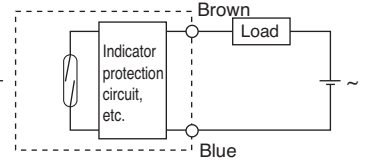

Example of Connection with PLC (Programmable Logic Controller)

•Sink input specifications

3-wire, NPN

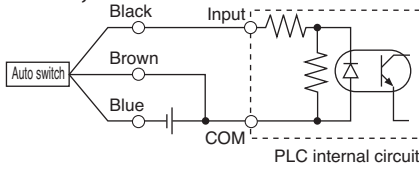

2-wire

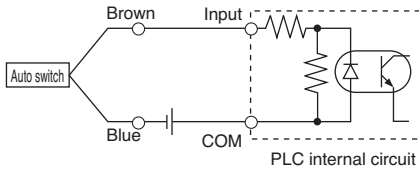

•Source input specifications

3-wire, PNP

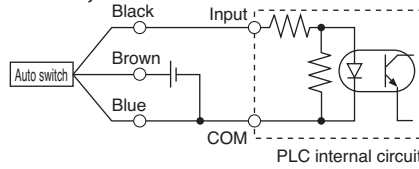

2-wire

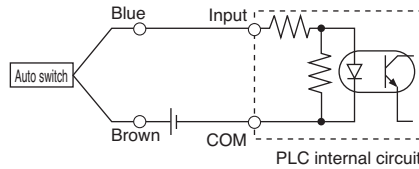

Connect according to the applicable PLC input specifications, as the connection method will vary depending on the PLC input specifications.

Example of AND (Series) and OR (Parallel) Connection

•3-wire

AND connection for NPN output (Using relays)

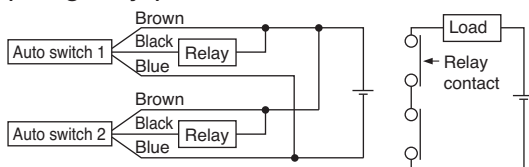

AND connection for NPN output (Performed with auto switches only)

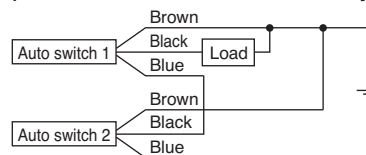

OR connection for NPN output

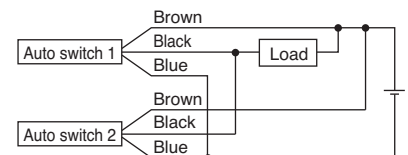

The indicator lights will light up when both auto switches are turned ON.

•2-wire

2-wire with 2-switch AND connection

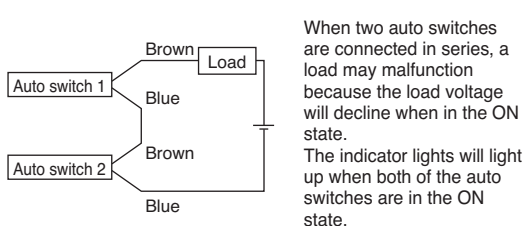

When two auto switches are connected in series, a load may malfunction because the load voltage will decline when in the ON state. The indicator lights will light up when both of the auto switches are in the ON state.

Load voltage at ON = Power supply voltage – Residual voltage x 2 pcs.
= 24 V – 4 V x 2 pcs.
= 16 V

Example: Power supply is 24 VDC
Internal voltage drop in auto switch is 4 V.

2-wire with 2-switch OR connection

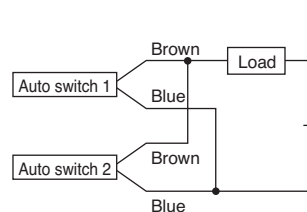

(Solid state auto switch) When two auto switches are connected in parallel, malfunction may occur because the load voltage will increase when in the OFF state.

Load voltage at OFF = Leakage current x 2 pcs. x Load impedance
= 1 mA x 2 pcs. x 3 kΩ
= 6 V

Example: Load impedance is 3 kΩ.
Leakage current from auto switch is 1 mA.

(Reed auto switch) Because there is no current leakage, the load voltage will not increase when turned OFF. However, depending on the number of auto switches in the ON state, the indicator lights may sometimes grow dim or not light up, due to the dispersion and reduction of the current flowing to the auto switches.

Solid State Auto Switch Direct Mounting Style D-M9N(V)/D-M9P(V)/D-M9B(V)



For details about certified products conforming to international standards, visit us at www.smcworld.com.

Grommet

- 2-wire load current is reduced (2.5 to 40 mA).
- Flexibility is 1.5 times greater than the conventional model (SMC comparison).
- Using flexible cable as standard spec.



⚠ Caution

Precautions

Fix the auto switch with the existing screw installed on the auto switch body. The auto switch may be damaged if a screw other than the one supplied is used.

Auto Switch Internal Circuit

D-M9N, D-M9NV

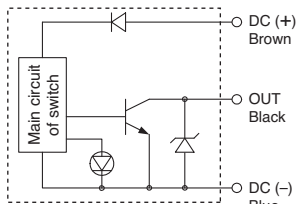

D-M9P, D-M9PV

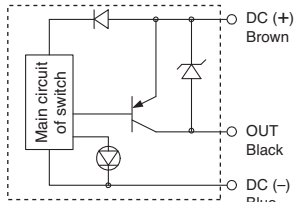

D-M9B, D-M9BV

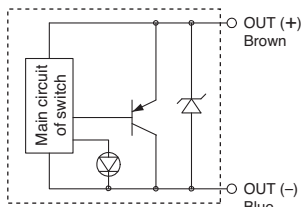

Auto Switch Specifications

PLC: Programmable Logic Controller

D-M9□, D-M9□V (With indicator light)						
Auto switch model	D-M9N	D-M9NV	D-M9P	D-M9PV	D-M9B	D-M9BV
Electrical entry direction	In-line	Perpendicular	In-line	Perpendicular	In-line	Perpendicular
Wiring type	3-wire				2-wire	
Output type	NPN		PNP		—	
Applicable load	IC circuit, Relay, PLC				24 VDC relay, PLC	
Power supply voltage	5, 12, 24 VDC (4.5 to 28 V)					
Current consumption	10 mA or less					
Load voltage	28 VDC or less		—		24 VDC (10 to 28 VDC)	
Load current	40 mA or less				2.5 to 40 mA	
Internal voltage drop	0.8 V or less at 10 mA (2 V or less at 40 mA)				4 V or less	
Leakage current	100 μA or less at 24 VDC				0.8 mA or less	
Indicator light	Red LED illuminates when turned ON.					
Standard	CE marking					

- Lead wires — Oilproof flexible heavy-duty vinyl cord: $\phi 2.7 \times 3.2$ ellipse, 0.15 mm², 2 cores (D-M9B(V)), 3 cores (D-M9N(V), D-M9P(V))

Note 1) Refer to page 13 for solid state auto switch common specifications.

Note 2) Refer to page 13 for lead wire lengths.

Weight

Unit: g

Auto switch model	D-M9N(V)	D-M9P(V)	D-M9B(V)	
Lead wire length (m)	0.5	8	8	7
	1	14	14	13
	3	41	41	38
	5	68	68	63

Dimensions

Unit: mm

D-M9□

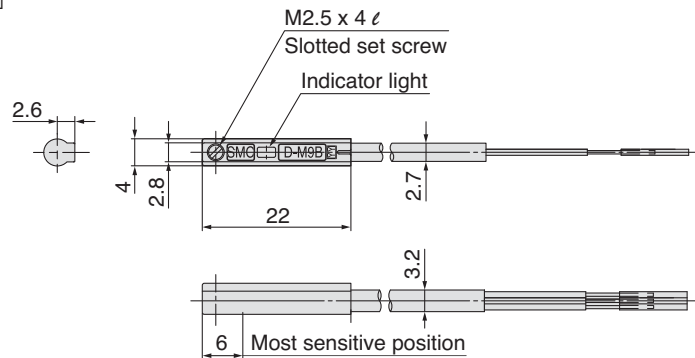

D-M9□V

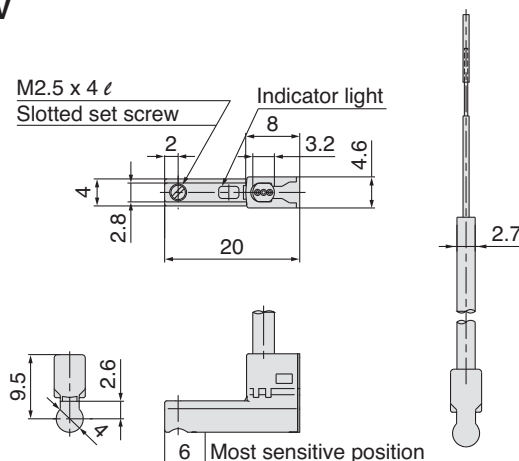

2-Color Indication Type Solid State Auto Switch Direct Mounting Style

D-M9NW(V)/D-M9PW(V)/D-M9BW(V)



For details about certified products conforming to international standards, visit us at www.smcworld.com.

Grommet

- 2-wire load current is reduced (2.5 to 40 mA).
- Flexibility is 1.5 times greater than the conventional model (SMC comparison).
- Using flexible cable as standard spec.
- A proper operating range can be determined by the color of the light. (Red → Green ← Red)

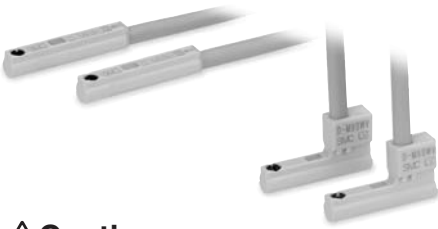

Caution

Precautions

Fix the auto switch with the existing screw installed on the auto switch body. The auto switch may be damaged if a screw other than the one supplied is used.

Auto Switch Internal Circuit

D-M9NW, D-M9NWV

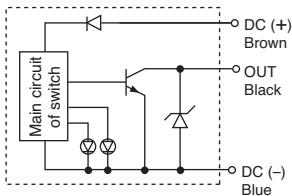

D-M9PW, D-M9PWV

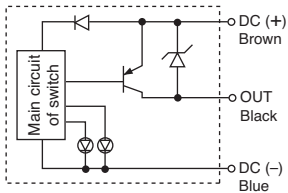

D-M9BW, D-M9BWV

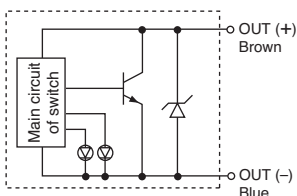

Indicator light / Display method

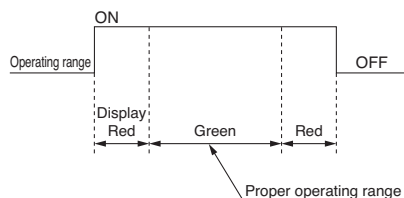

Auto Switch Specifications

PLC: Programmable Logic Controller

D-M9□W, D-M9□WV (With indicator light)						
Auto switch model	D-M9NW	D-M9NWV	D-M9PW	D-M9PWV	D-M9BW	D-M9BWV
Electrical entry direction	In-line	Perpendicular	In-line	Perpendicular	In-line	Perpendicular
Wiring type	3-wire				2-wire	
Output type	NPN		PNP		—	
Applicable load	IC circuit, Relay, PLC				24 VDC relay, PLC	
Power supply voltage	5, 12, 24 VDC (4.5 to 28 V)				—	
Current consumption	10 mA or less				—	
Load voltage	28 VDC or less		—		24 VDC (10 to 28 VDC)	
Load current	40 mA or less				2.5 to 40 mA	
Internal voltage drop	0.8 V or less at 10 mA (2 V or less at 40 mA)				4 V or less	
Leakage current	100 μA or less at 24 VDC				0.8 mA or less	
Indicator light	Operating range Red LED illuminates. Proper operating range Green LED illuminates.					
Standard	CE marking					

- Lead wires — Oilproof flexible heavy-duty vinyl cord: $\phi 2.7 \times 3.2$ ellipse, 0.15 mm², 2 cores (D-M9BW(V)), 3 cores (D-M9NW(V), D-M9PW(V))

Note 1) Refer to page 13 for solid state auto switch common specifications.

Note 2) Refer to page 13 for lead wire lengths.

Weight

Unit: g

Auto switch model	D-M9NW(V)	D-M9PW(V)	D-M9BW(V)
Lead wire length (m)	0.5	8	7
	1	14	13
	3	41	38
	5	68	63

Dimensions

Unit: mm

D-M9□W

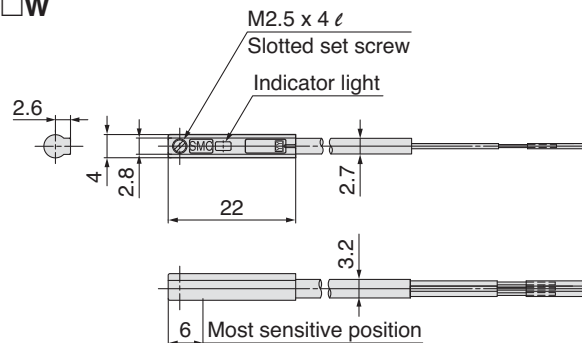

D-M9□WV

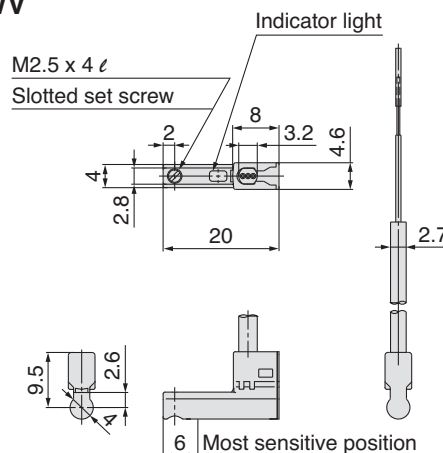

Water Resistant 2-Color Indication Type Solid State Auto Switch: Direct Mounting Style D-M9NA(V)/D-M9PA(V)/D-M9BA(V)

Grommet

- Water (coolant) resistant type
- 2-wire load current is reduced (2.5 to 40 mA).
- A proper operating range can be determined by the color of the light. (Red → Green ← Red)
- Using flexible cable as standard spec.



⚠ Caution

Precautions

Fix the auto switch with the existing screw installed on the auto switch body. The auto switch may be damaged if a screw other than the one supplied is used.

Auto Switch Internal Circuit

D-M9NA, D-M9NAV

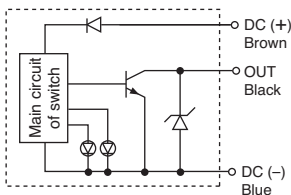

D-M9PA, D-M9PAV

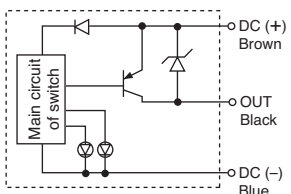

D-M9BA, D-M9BAV

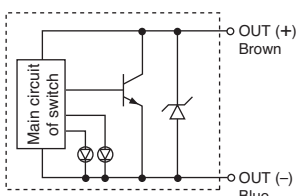

Indicator light/Display method

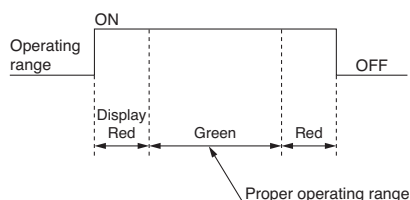

Auto Switch Specifications

PLC: Programmable Logic Controller

D-M9□A, D-M9□AV (With indicator light)						
Auto switch model	D-M9NA	D-M9NAV	D-M9PA	D-M9PAV	D-M9BA	D-M9BAV
Electrical entry direction	In-line	Perpendicular	In-line	Perpendicular	In-line	Perpendicular
Wiring type	3-wire				2-wire	
Output type	NPN		PNP		—	
Applicable load	IC circuit, Relay, PLC				24 VDC relay, PLC	
Power supply voltage	5, 12, 24 VDC (4.5 to 28 V)				—	
Current consumption	10 mA or less				—	
Load voltage	28 VDC or less		—		24 VDC (10 to 28 VDC)	
Load current	40 mA or less				2.5 to 40 mA	
Internal voltage drop	0.8 V or less at 10 mA (2 V or less at 40 mA)				4 V or less	
Leakage current	100 μA or less at 24 VDC				0.8 mA or less	
Indicator light	Operating range Red LED illuminates. Proper operating range Green LED illuminates.					
Standard	CE marking					

- Lead wires — Oilproof flexible heavy-duty vinyl cord: $\phi 2.7 \times 3.2$ ellipse, 0.15 mm², 2 cores (D-M9BA(V)), 3 cores (D-M9NA(V), D-M9PA(V))

Note 1) Refer to page 13 for solid state auto switch common specifications.

Note 2) Refer to page 13 for lead wire lengths.

Weight

Unit: g

Auto switch model	D-M9NA(V)	D-M9PA(V)	D-M9BA(V)	
Lead wire length (m)	0.5	8	8	7
	1	14	14	13
	3	41	41	38
	5	68	68	63

Dimensions

Unit: mm

D-M9□A

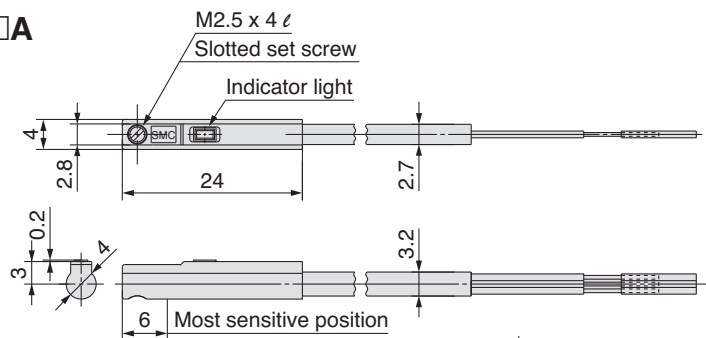

D-M9□AV

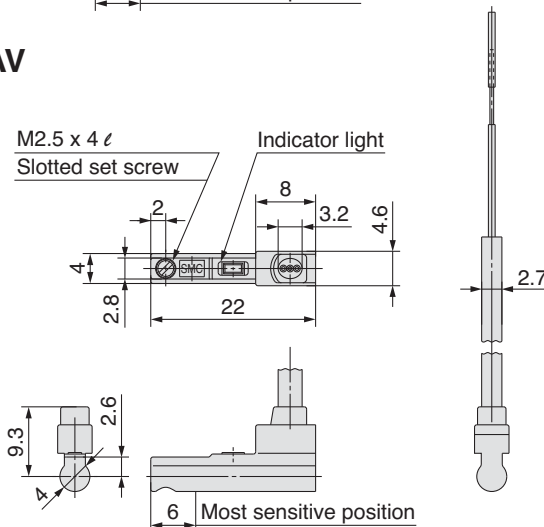

Reed Auto Switch Direct Mounting Style D-A90(V)/D-A93(V)/D-A96(V)



For details about certified products conforming to international standards, visit us at www.smcworld.com.

Auto Switch Specifications

PLC: Programmable Logic Controller

Grommet



Caution

Precautions

Fix the auto switch with the existing screw installed on the auto switch body. The auto switch may be damaged if a screw other than the one supplied is used.

Auto Switch Internal Circuit

D-A90, A90V

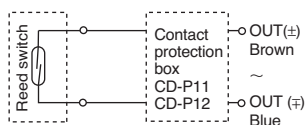

D-A93, A93V

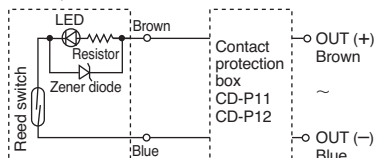

D-A96, A96V

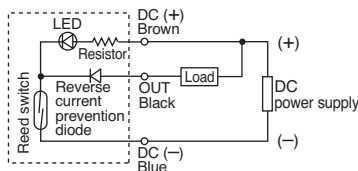

Note 1) Operating load is an induction load.

Note 2) Wiring to the load is 5 m or longer.

Note 3) Load voltage is 100 VAC.

Use the contact protection box in any of the above listed situations. The contact point life may decrease. (Refer to page 14 for contact protection box.)

D-A90, D-A90V (Without indicator light)			
Auto switch model	D-A90, D-A90V		
Applicable load	IC circuit, Relay, PLC		
Load voltage	24 V _{DC} ^{AC} or less	48 V _{DC} ^{AC} or less	100 V _{DC} ^{AC} or less
Maximum load current	50 mA	40 mA	20 mA
Contact protection circuit	None		
Internal resistance	1 Ω or less (Including lead wire length of 3 m)		
Standard	CE marking		
D-A93, D-A93V, D-A96, D-A96V (With indicator light)			
Auto switch model	D-A93, D-A93V		D-A96, D-A96V
Applicable load	Relay, PLC		IC circuit
Load voltage	24 VDC	100 VAC	4 to 8 VDC
Load current range and Maximum load current ⁽³⁾	5 to 40 mA	5 to 20 mA	20 mA
Contact protection circuit	None		
Internal voltage drop	D-A93: 2.4 V or less (up to 20 mA)/3 V or less (up to 40 mA) D-A93V: 2.7 V or less		0.8 V or less
Indicator light	Red LED illuminates when turned ON.		
Standard	CE marking		

Lead wires

D-A90(V)/D-A93(V)—Oilproof heavy-duty vinyl cord, $\phi 2.7$, 0.18 mm² x 2 cores (Brown, Blue), 0.5 m

D-A96(V)—Oilproof heavy-duty vinyl cord, $\phi 2.7$, 0.15 mm² x 3 cores (Brown, Black, Blue), 0.5 m

Note 1) Refer to page 13 for reed auto switch common specifications.

Note 2) Refer to page 13 for lead wire lengths.

Note 3) Under 5 mA, the strength of the indicator light is poor. In some cases, visibility of the indicator light will not be possible where the output signal is less than 2.5 mA. However, there is no problem in terms of contact output, when an output signal exceeds 1 mA or more.

Weight

Unit: g

Model	D-A90	D-A90V	D-A93	D-A93V	D-A96	D-A96V
Lead wire length (m)	0.5	6	6	6	8	8
	3	30	30	30	41	41

Dimensions

Unit: mm

D-A90/D-A93/D-A96

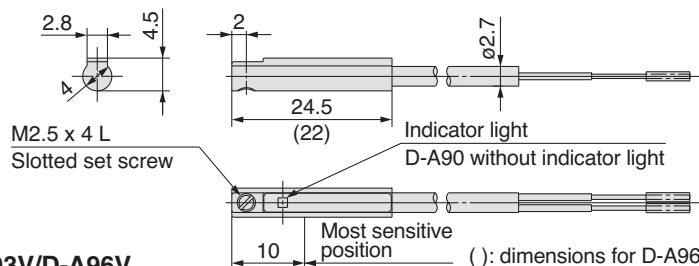

D-A90V/D-A93V/D-A96V

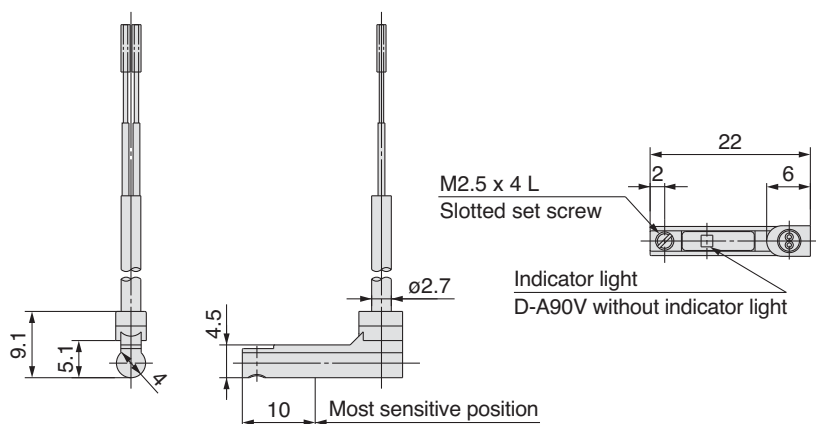

Magnetic Field Resistant 2-Color Display Solid State Auto Switch

D-P3DWSC/D-P3DWSE [®] US

(Electrical entry: Pre-wired connector)



For details about certified products conforming to international standards, visit us at www.smcworld.com.

- It is possible to use in an environment which generates a magnetic field disturbance (AC magnetic field).
- A proper operating range can be determined by the color of the light. (Red → Green ← Red)

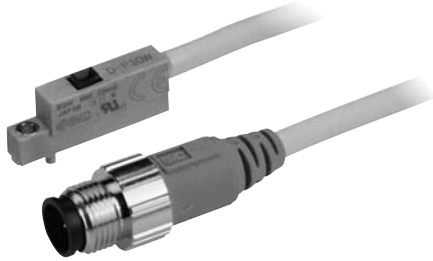

Caution

Precautions

For single-phase AC welding machines
If it is used for current inverter welders (including rectifying type) and condenser type welders, the magnetic field resistance is reduced. Please contact SMC regarding the performance.

Auto Switch Internal Circuit

D-P3DWSC

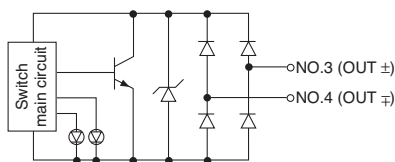

D-P3DWSE

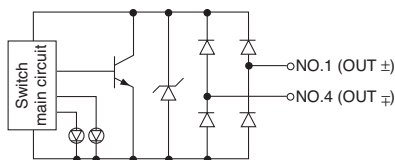

Indicator light/Display method

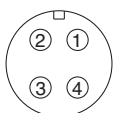
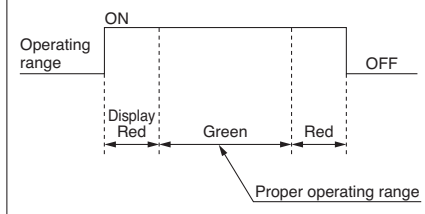

Connector pin assignment

Auto Switch Specifications

PLC: Programmable Logic Controller

D-P3DWSC/E (With indicator light)		
Auto switch model	D-P3DWSC	D-P3DWSE
Applicable load	24 VDC relay, PLC	
Load voltage	24 VDC (20 to 28 VDC)	
Load current	6 to 40 mA	
Internal voltage drop	5 V or less	
Leakage current	1 mA or less at 24 VDC	
Operating time	40 ms or less	
Indicator light	Operating range.....Red LED illuminates. Proper operating range.....Green LED illuminates.	
Standards	CE marking, UL (CSA), RoHS	

- Lead wire — Oilproof heavy-duty vinyl cable, $\phi 4.8$, 0.5 mm², 2 cores
- Impact resistance — Switch: 1000 m/s², Connector: 300 m/s²
- Insulation resistance — 50 M Ω or more at 500 VDC Mega (between lead wire and case)
- Withstand voltage — 1000 VAC for 1 minute (between lead wire and case)
- Ambient temperature — -10 to 60°C
- Enclosure — IEC60529 standard IP67
- Polarity: Non-polar

Magnetic Field Resistance

If the current of the AC welding machine is 16000 A or lower, the auto switch can be used, even if the distance between the welding conductor (gun cable) and the cylinder/actuator or auto switch is 0 mm. Please contact SMC when the AC welding current exceeds 16000 A.

Weight

Unit: g

Auto switch model	D-P3DWSC	D-P3DWSE
Lead wire length (m)	0.3	23

Dimensions

Unit: mm

Body

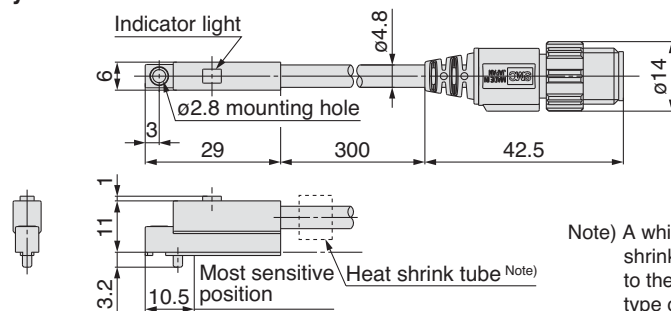

Note) A white color heat shrink tube is attached to the D-P3DWSE type only.

Auto switch mounting bracket (For round groove mounting: BQ3-032S)

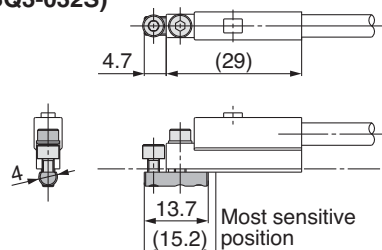

Auto switch mounting bracket (For square groove mounting: BMG5-025S)

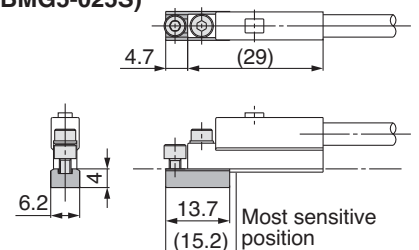

* When the auto switch is ordered on its own, the auto switch mounting bracket is not enclosed. In that case, please order it separately.

Magnetic Field Resistant 2-Color Display Solid State Auto Switch

D-P3DW/L/Z

(Electrical entry: Grommet)



For details about certified products conforming to international standards, visit us at www.smcworld.com.

- It is possible to use in an environment which generates a magnetic field disturbance (AC magnetic field).
- A proper operating range can be determined by the color of the light. (Red → Green ← Red)

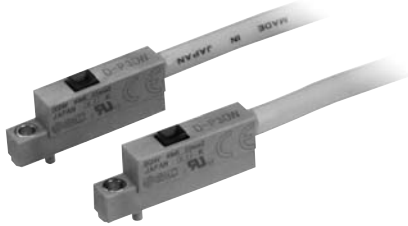

Caution

Precautions

For single-phase AC welding machines
If it is used for current inverter welders (including rectifying type) and condenser type welders, the magnetic field resistance is reduced. Please contact SMC regarding the performance.

Auto Switch Internal Circuit

D-P3DW/L/Z

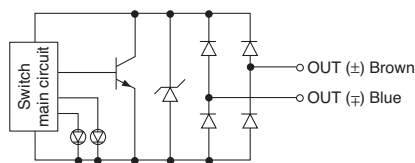

Indicator light/Display method

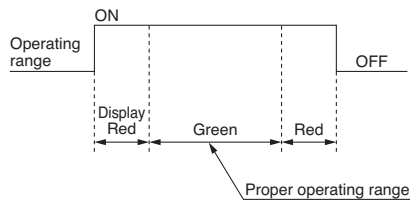

Auto Switch Specifications

PLC: Programmable Logic Controller

D-P3DW/L/Z (With indicator light)	
Auto switch model	D-P3DW/L/Z
Applicable load	24 VDC relay, PLC
Load voltage	24 VDC (20 to 28 VDC)
Load current	6 to 40 mA
Internal voltage drop	5 V or less
Leakage current	1 mA or less at 24 VDC
Operating time	40 ms or less
Indicator light	Operating range.....Red LED illuminates. Proper operating range.....Green LED illuminates.
Standards	CE marking, UL (CSA), RoHS

- Lead wire — Oilproof heavy-duty vinyl cable, $\phi 4.8$, 0.5 mm², 2 cores, D-P3DW: 0.5 m, D-P3DWL: 3 m, D-P3DWZ: 5 m
- Impact resistance — Switch: 1000 m/s²
- Insulation resistance — 50 M Ω or more at 500 VDC Mega (between lead wire and case)
- Withstand voltage — 1000 VAC for 1 minute (between lead wire and case)
- Ambient temperature — -10 to 60°C
- Enclosure — IEC60529 standard IP67
- Polarity: Non-polar

Magnetic Field Resistance

If the current of the AC welding machine is 16000 A or lower, the auto switch can be used, even if the distance between the welding conductor (gun cable) and the cylinder/actuator or auto switch is 0 mm. Please contact SMC when the AC welding current exceeds 16000 A.

Weight

Unit: g

Auto switch model	D-P3DW/L/Z	
Lead wire length (m)	0.5	20
	3	102
	5	168

Dimensions

Unit: mm

Body

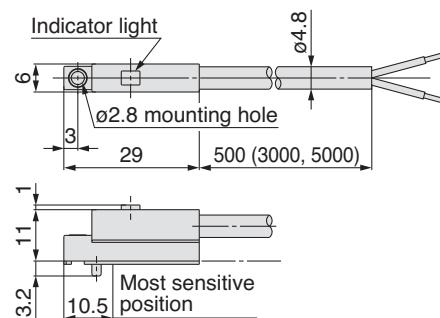

Auto switch mounting bracket (For round groove mounting: BQ3-032S)

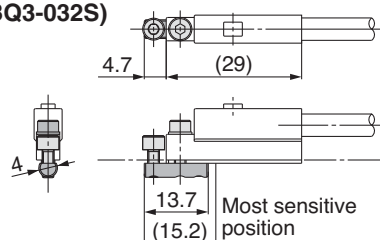

Auto switch mounting bracket (For square groove mounting: BMG5-025S)

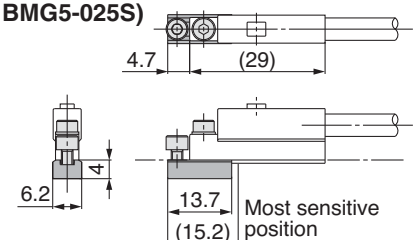

* When the auto switch is ordered on its own, the auto switch mounting bracket is not enclosed. In that case, please order it separately.

ISO Standards [ISO/21287] Compact Cylinder (ATEX directive category 2)

Series 55-C55

ø20, ø25, ø32, ø40, ø50, ø63, ø80, ø100



How to Order

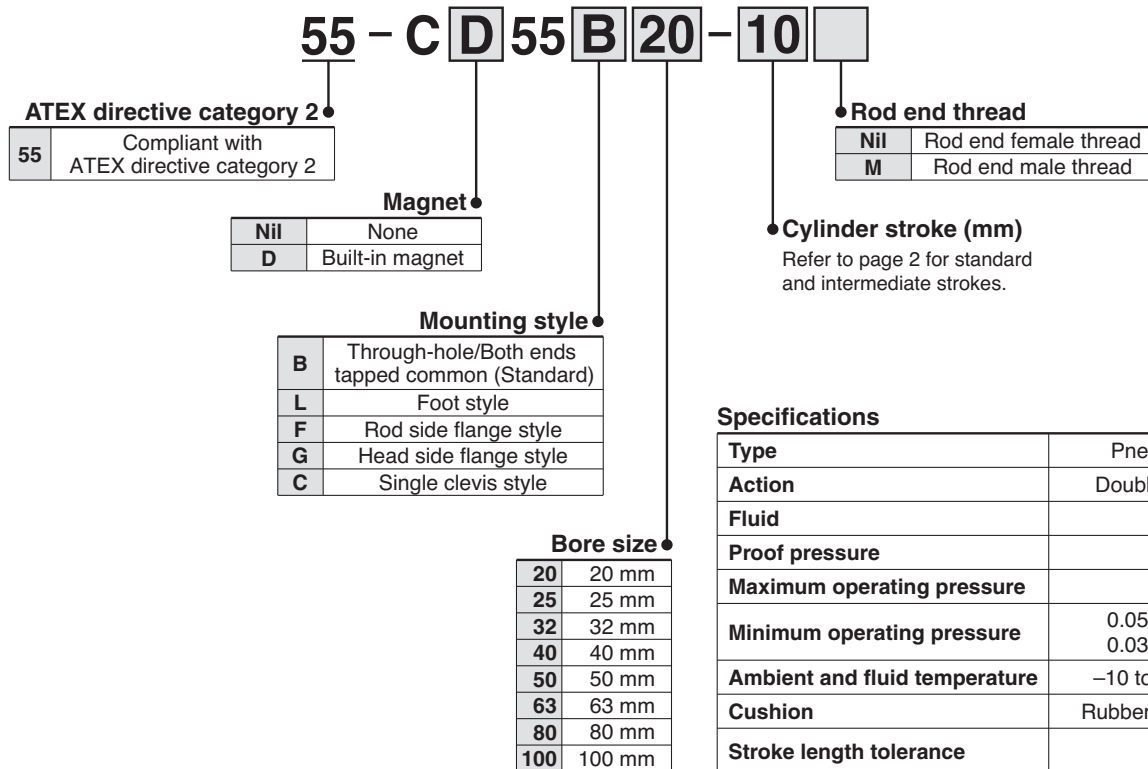

Specifications

Type	Pneumatic (Non-lube)
Action	Double acting, Single rod
Fluid	Air
Proof pressure	1.5 MPa
Maximum operating pressure	1.0 MPa
Minimum operating pressure	0.05 MPa (ø20 to ø63) 0.03 MPa (ø80, ø100)
Ambient and fluid temperature	-10 to 60°C (No freezing)
Cushion	Rubber bumper on both end
Stroke length tolerance	+1.0 0 mm
Mounting	Through-hole/Both ends tapped common
Piston speed	ø20 to ø63: 50 to 500 mm/s ø80, ø100: 50 to 300 mm/s

Note) Stroke length tolerance dose not include the amount of bumper change.

When using an Auto switch, select the appropriate switch from the following table and order it separately.

Applicable auto switch specifications

Auto switch only conforms to Category 3. (II 3GD EEx nA II T5x -10°C ≤ Ta ≤ +60°C IP67)
For detailed specifications on the D-M9P(V), A93(V) and A90(V), please refer to page 16, 19.
(Note: Reed auto switches for 100 VAC and 100 VDC are not within the specification.)

Type	Model	Electrical entry	Indicator light	Wiring (output)	Load voltage			Lead wire length (m) *			Applicable load	
					DC	AC		0.5 (Nil)	3 (L)	5 (Z)		
Reed switch	D-M9PV□-588	Grommet (Perpendicular)	Yes	3-wire (PNP)	24 V	5V, 12 V	-	●	●	○	IC circuit	Relay, PLC
	D-M9P□-588	Grommet (in-line)						●	●	○		
	D-M9PWV□-588	Grommet (Perpendicular)	Yes (2-color)					●	●	○		
	D-M9PW□-588	Grommet (in-line)						●	●	○		
Solid state switch	D-A93V□-588	Grommet (Perpendicular)	Yes	2-wire	24 V	12 V	-	●	●	●	-	IC circuit
	D-A90V□-588		No		24 V or less	48 V	48 V or less	●	●	-		
	D-A93□-588	Grommet (in-line)	Yes		24 V	12 V	-	●	●	●	-	
	D-A90□-588		No		24 V or less	48 V	48 V or less	●	●	-		

* Lead wire length symbols: 0.5 m Nil (Example) D-A93-588
3 m L (Example) D-A93L-588
5 m Z (Example) D-A93Z-588

* ○ solid state auto switch is available after receiving an order.

Note) When mounting an auto switch on a 55-series (Category 2) model, the ATEX class of the cylinder with auto switch changes to Category 3, which is the same class as the auto switch.

Safety Instructions

These safety instructions are intended to prevent hazardous situations and/or equipment damage. These instructions indicate the level of potential hazard with the labels of “**Caution**,” “**Warning**” or “**Danger**.” They are all important notes for safety and must be followed in addition to International Standards (ISO/IEC) *1), and other safety regulations.

 **Caution:** **Caution** indicates a hazard with a low level of risk which, if not avoided, could result in minor or moderate injury.

 **Warning:** **Warning** indicates a hazard with a medium level of risk which, if not avoided, could result in death or serious injury.

 **Danger:** **Danger** indicates a hazard with a high level of risk which, if not avoided, will result in death or serious injury.

- *1) ISO 4414: Pneumatic fluid power – General rules relating to systems.
ISO 4413: Hydraulic fluid power – General rules relating to systems.
IEC 60204-1: Safety of machinery – Electrical equipment of machines.
(Part 1: General requirements)
ISO 10218-1: Manipulating industrial robots - Safety.
etc.

Warning

1. The compatibility of the product is the responsibility of the person who designs the equipment or decides its specifications.

Since the product specified here is used under various operating conditions, its compatibility with specific equipment must be decided by the person who designs the equipment or decides its specifications based on necessary analysis and test results. The expected performance and safety assurance of the equipment will be the responsibility of the person who has determined its compatibility with the product. This person should also continuously review all specifications of the product referring to its latest catalog information, with a view to giving due consideration to any possibility of equipment failure when configuring the equipment.

2. Only personnel with appropriate training should operate machinery and equipment.

The product specified here may become unsafe if handled incorrectly. The assembly, operation and maintenance of machines or equipment including our products must be performed by an operator who is appropriately trained and experienced.

3. Do not service or attempt to remove product and machinery/equipment until safety is confirmed.

1. The inspection and maintenance of machinery/equipment should only be performed after measures to prevent falling or runaway of the driven objects have been confirmed.
2. When the product is to be removed, confirm that the safety measures as mentioned above are implemented and the power from any appropriate source is cut, and read and understand the specific product precautions of all relevant products carefully.
3. Before machinery/equipment is restarted, take measures to prevent unexpected operation and malfunction.

4. Contact SMC beforehand and take special consideration of safety measures if the product is to be used in any of the following conditions.

1. Conditions and environments outside of the given specifications, or use outdoors or in a place exposed to direct sunlight.
2. Installation on equipment in conjunction with atomic energy, railways, air navigation, space, shipping, vehicles, military, medical treatment, combustion and recreation, or equipment in contact with food and beverages, emergency stop circuits, clutch and brake circuits in press applications, safety equipment or other applications unsuitable for the standard specifications described in the product catalog.
3. An application which could have negative effects on people, property, or animals requiring special safety analysis.
4. Use in an interlock circuit, which requires the provision of double interlock for possible failure by using a mechanical protective function, and periodical checks to confirm proper operation.

Caution

1. The product is provided for use in manufacturing industries.

The product herein described is basically provided for peaceful use in manufacturing industries.
If considering using the product in other industries, consult SMC beforehand and exchange specifications or a contract if necessary.
If anything is unclear, contact your nearest sales branch.

Limited warranty and Disclaimer/ Compliance Requirements

The product used is subject to the following “Limited warranty and Disclaimer” and “Compliance Requirements”.

Read and accept them before using the product.

Limited warranty and Disclaimer

1. The warranty period of the product is 1 year in service or 1.5 years after the product is delivered.*2)
Also, the product may have specified durability, running distance or replacement parts. Please consult your nearest sales branch.
2. For any failure or damage reported within the warranty period which is clearly our responsibility, a replacement product or necessary parts will be provided.
This limited warranty applies only to our product independently, and not to any other damage incurred due to the failure of the product.
3. Prior to using SMC products, please read and understand the warranty terms and disclaimers noted in the specified catalog for the particular products.

*2) Vacuum pads are excluded from this 1 year warranty.

A vacuum pad is a consumable part, so it is warranted for a year after it is delivered.
Also, even within the warranty period, the wear of a product due to the use of the vacuum pad or failure due to the deterioration of rubber material are not covered by the limited warranty.

Compliance Requirements

1. The use of SMC products with production equipment for the manufacture of weapons of mass destruction (WMD) or any other weapon is strictly prohibited.
2. The exports of SMC products or technology from one country to another are governed by the relevant security laws and regulations of the countries involved in the transaction. Prior to the shipment of a SMC product to another country, assure that all local rules governing that export are known and followed.

Record of changes

Edition B * Bore sizes ø80, ø100 added.

NZ

 **Safety Instructions** Be sure to read “Handling Precautions for SMC Products” (M-E03-3) before using.

SMC Corporation

Akihabara UDX 15F,
4-14-1, Sotokanda, Chiyoda-ku, Tokyo 101-0021, JAPAN
Phone: 03-5207-8249 Fax: 03-5298-5362
URL <http://www.smcworld.com>
© 2009 SMC Corporation All Rights Reserved

Specifications are subject to change without prior notice and any obligation on the part of the manufacturer.

D-G

1st printing JO printing NZ 6000SZ Printed in Japan.

This catalog is printed on recycled paper with concern for the global environment.