

Adapter Set

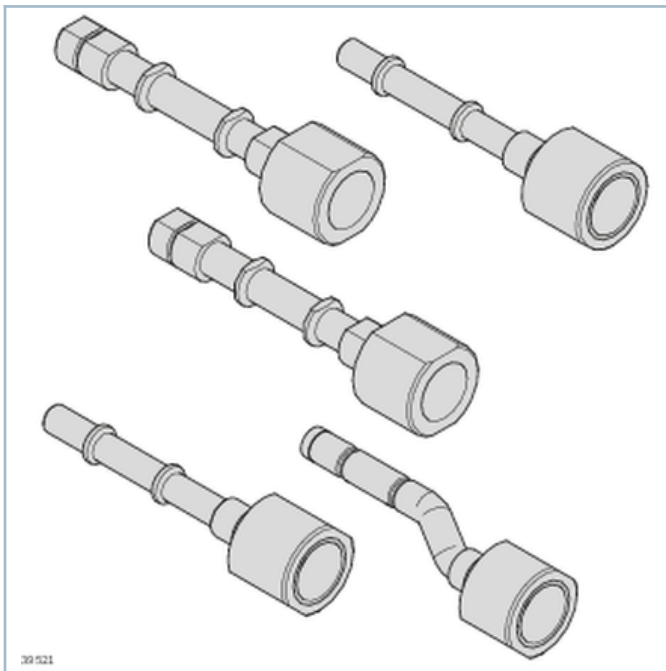
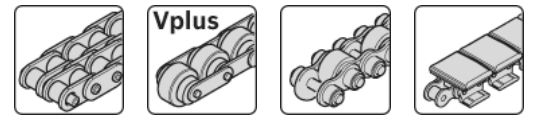

- Specific adapter sets with compatible lubrication pins for different drive modules

[PDF](#) Assembly instructions

Technical data

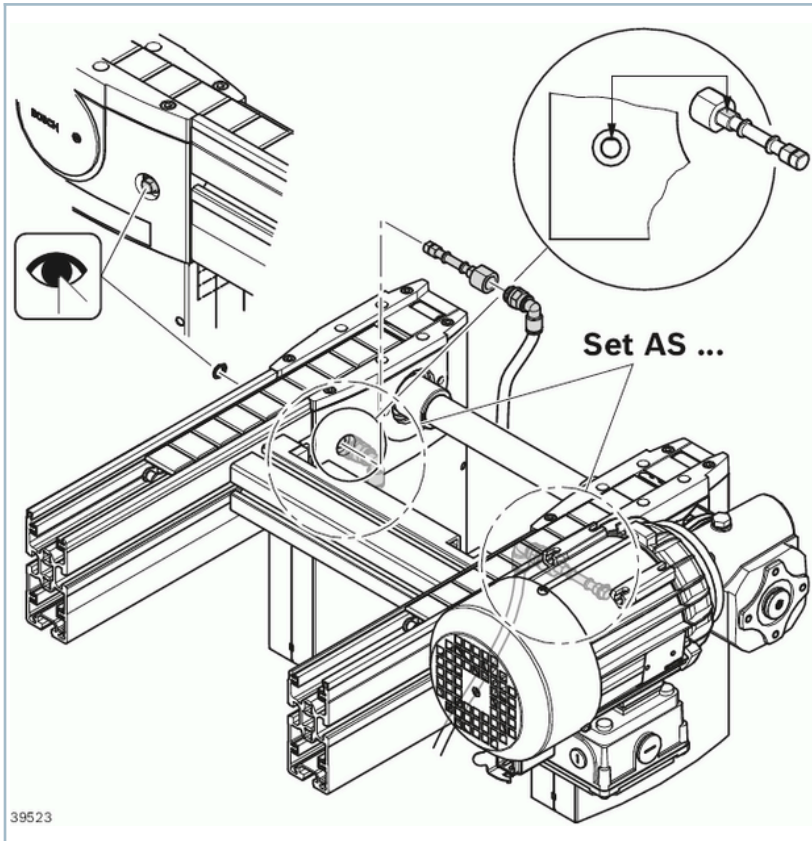

Ordering codes

	No.
Adapter set LU 2 for AS 2/C-100, AS 2/C-250, BS 2/C, HQ 2/C-H	384254348 3
LU 2 adapter set for AS 2/C-400, AS 2/C-700, BS 2/C-H ¹⁾	384254348 4
LU 2 adapter set for AS 2/R-300, AS 2/R-700, BS 2/R, BS 2/R-H with RV = 1, BS 2/G-250, HQ 2/G-H ²⁾	384254348 5
LU 2 adapter set for AS 2/R-1200, AS 2/R-2200, BS 2/R-H with RV = 0 ³⁾	384254348 6
LU 2 adapter set for AS 2/R-V-1200, AS 2/R-V-2200, BS 2/R-V-1200 ⁴⁾	384254348 7
LU 2 adapter set for HQ 2/U-H	384254857

1) LU 2: AS 2/C-400 and AS 2/C-700 (assembly on UM 2/C-170 when b = 160 mm); BS 2/C-H (assembly on UM 2/C-170; UM 2/R-170 when b = 160 mm)

2) LU 2: BS 2/R-H with RV = 1: assembly on UM return unit

3) LU 2: AS 2/R-1200 and AS 2/R-2200 (assembly on UM 2/R-170 when b = 160 mm); BS 2/R-H with RV = 0 (assembly on UM 2/C-170; UM 2/R-170 when b = 160 mm)

4) LU 2: Assembly on UM 2/R-170 when b = 160 mm