

82M-3 SERIES

Pneumatic Power Clamps | Technical Specifications

Model	Max. Holding Torque (Nm)	Clamping Torque at 5 bar (Nm)	Cylinder Ø (mm)	Weight (kg)	Air Consumption per double stroke at 5 bar (liter)
82M-3E...80..	3000	850	80	8,7	6,3
82M-3E...8N..				8,8	
82M-3E...8A..					
82M-3E...8B..					

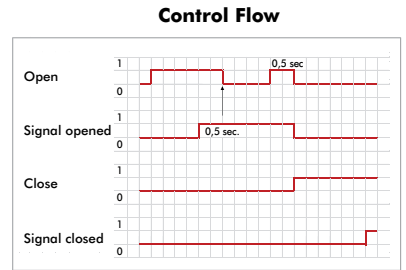
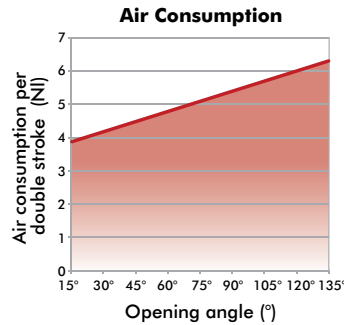
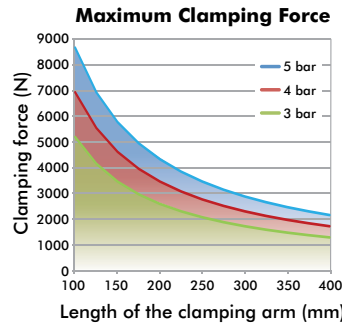
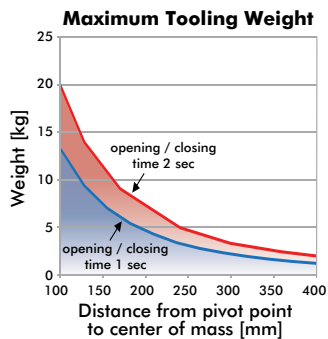

Internal Hold Open Device
8A/8B Cylinder Option

ATTENTION: Calculation tool available. Please consult factory.

Center of Mass

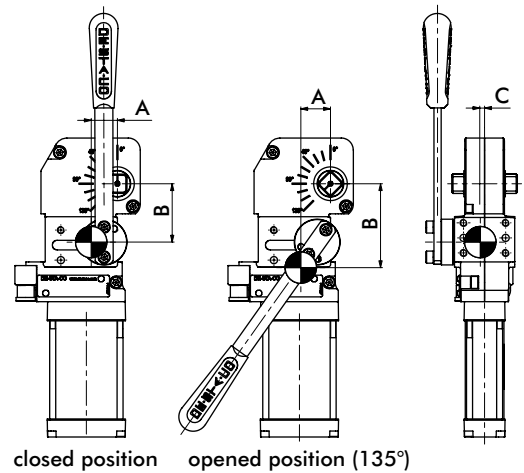
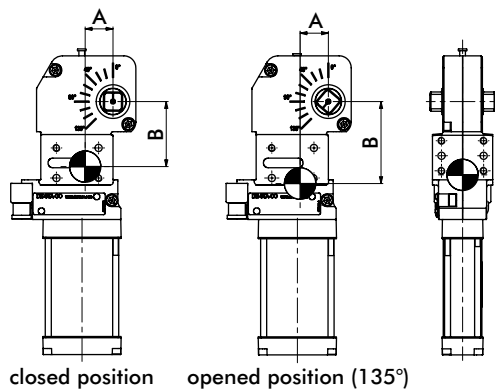

Model	Without Handle				Weight
	A		B		
	Closed	Open	Closed	Open	
82M-3E...40..	23	24	55	69	1,5
82M-3B...40..	24	24	54	68	
82M-3E...4A..	22	23	72	86	1,6
82M-3B...4A..	23		85		
82M-3E...50..	24	25	70	87	2,8
82M-3E...5N..			83	99	
82M-3E...5A..			83	99	
82M-3E...5B..			83	99	
82M-3...63..	27	28	88	103	3,8
82M-3...6N..			98	114	
82M-3...6A..			98	114	
82M-3...6B..			98	114	
82M-3E...80..	36	37	98	123	8,7
82M-3E...8N..			98	123	
82M-3E...8A..			104	129	
82M-3E...8B..			104	129	

Model	With Handle				C	Weight
	A		B			
	Closed	Open	Closed	Open		
82M-3E...40..	22	25	49	70	4	1,6
82M-3B...40..	24	27	46	67		
82M-3E...50..	23	30	62	85	3	3,1
82M-3E...5N..			62	85		
82M-3...63..	26	30	80	102	3	4,2
82M-3...6N..			80	102		
82M-3E...80..	35	38	93	122	2	9,2
82M-3E...8N..			93	122		