

Catalogue No: **800FM-KM21**

KEY SEL SW 22.5mm METAL 2P MAIN LKR CODE 3825

Operator Control Devices > Pushbuttons and Control Switches > Pushbuttons and Pilot Lights > Allen-Bradley 800F Pushbuttons and Pilot Lights > 800F Selector Switches > 2-Position Keyed Selector Switches



KEY SELECTOR SW 22.5mm METAL 2 POSITION KR L 3825



- The 800F line of 22.5 mm push buttons is designed and manufactured to demanding performance specifications to ensure you receive optimized durability and performance.
- 800FP operators are made of industrial grade thermoplastic for superior chemical resistance.
- 800FM operators are constructed of tough die cast zinc alloy, finished with chromate plating that can be used in the most arduous applications.

Representative Photo Only
(actual product may vary based on configuration selections)

SPECIFICATIONS

Product Series	800FM
Component Type Pushbutton and Pilot Lights	Selector Switch
Operator Type	Selector Switch, Key, 2-Position type
Operator Positions (from Vertical)	30° -30°
Key Removal Position(s)	Left
Key Code	3825 (standard)
Operator Action, Left	Latched / Maintained
Operator Action, Right	Latched / Maintained
Colour, Operator	Black colour
Material, Operator	Zinc Alloy, Die-Cast, Chrome-Plated material
Colour, Operator Insert	White
Material, Bezel	Zinc
Coupling Plate Included	No Y / N
Mounting	22.5mm Mounting
Contact Block Included	No
Tightening Torque, Nominal	4.4 Nm
Mechanical service life	1000000 cycles
RoHS Approved	Yes
CE Marked	Yes
Operating Temperature, Max	70 °C max
Operating Temperature, Min	-25 °C min
Storage Temperature, Max	85 °C max
Storage Temperature, Min	-40 °C min
Relative humidity, min	50 %RH
Relative Humidity, Max	95 %RH
IP Rating	IP66 IP65
Shock Acceleration (Max.)	100 g

Catalogue No: **800FM-KM21**

KEY SEL SW 22.5mm METAL 2P MAIN LKR CODE 3825

Operator Control Devices > Pushbuttons and Control Switches > Pushbuttons and Pilot Lights > Allen-Bradley 800F Pushbuttons and Pilot Lights > 800F Selector Switches > 2-Position Keyed Selector Switches



Shock Duration (Max.)	11 ms
Vibration Acceleration (Max.)	10 g
Vibration Displacement (Peak to Peak Max.)	1.52 mm
Vibration Frequency, Operational (Max.)	2000 Hz
Vibration Duration (Max.)	180 min
Standards Compliance	NEMA ICS-5 UL 508 EN 60947-1 EN 60947-5-1 EN 60947-5-5 IEC 60947-1 ISO 13850
Certifications	UR UL CSA CCC CE RoHS
Shipping Approvals	ABS (American Bureau of Shipping)

REFERENCES

IECEX Certificate	-
Supplier Declaration of Conformity:	-
Installation Guide:	-
User Manual:	-
Manufacturer Datasheet:	800FMKM21 Manufacturer Datasheet
Manufacturer Catalogue & Product Selection:	800FMKM21 Manufacturer Product Selection Guide

Key Selector Switch and Key Ejected SensEject Operators

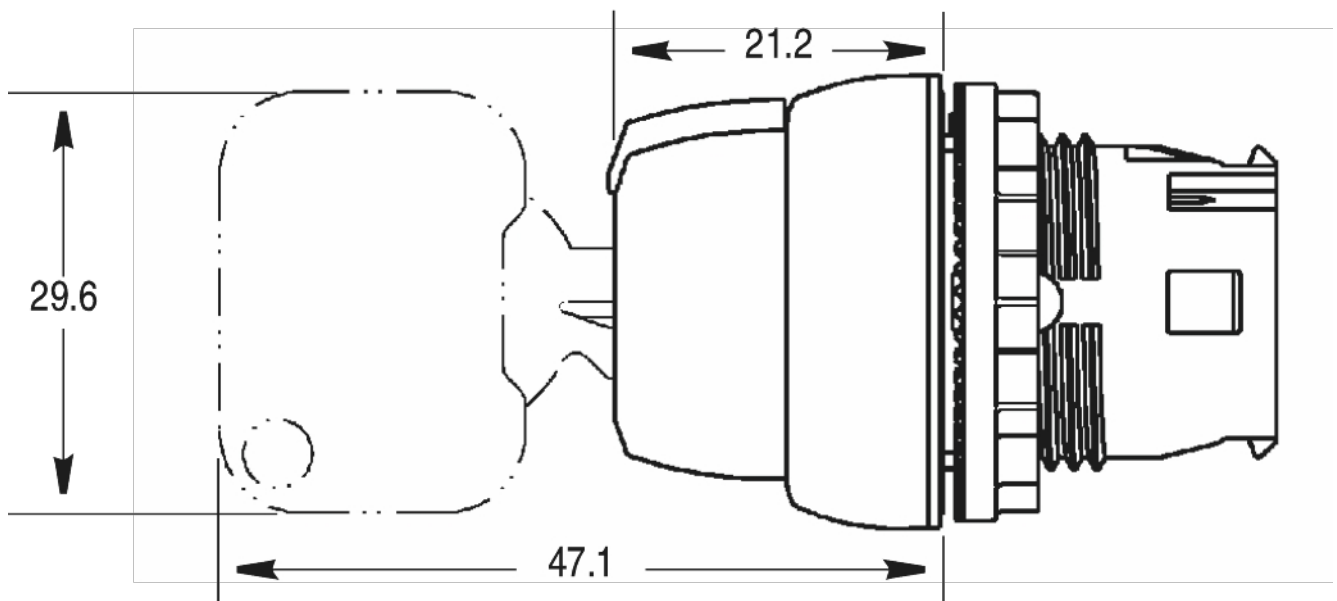

Catalogue No: **800FM-KM21**

KEY SEL SW 22.5mm METAL 2P MAIN LKR CODE 3825

Operator Control Devices > Pushbuttons and Control Switches > Pushbuttons and Pilot Lights > Allen-Bradley 800F
Pushbuttons and Pilot Lights > 800F Selector Switches > 2-Position Keyed Selector Switches



Dimension Diagram