

HYDAC

INTERNATIONAL

Feed Pumps

Direct Drive Series

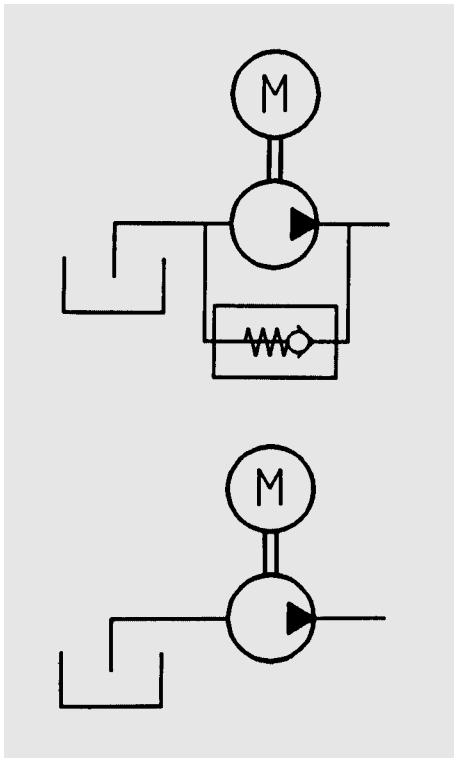

FEED PUMP SERIES FZP AND MFZP

1. GENERAL

The feed pump, type FZP, is a direct drive vane pump with constant flow rate. It is available with flanged motor (MFZP) and comes with internal pressure relief valve. The charging pressure of this valve starts at approx. 20 % below nominal pressure setting, which causes a reduction of the flow rate in this pressure range. Please follow Operating and Maintenance instructions.

1.1. SPECIAL FEATURES

- vane type pump for low pressure range
- direct drive, i.e. no bell housing or coupling required
- compact design

1.2. APPLICATIONS

- filter circuits
- cooling circuits
- lubrication applications
- pump transfer units

1.3. SYMBOL

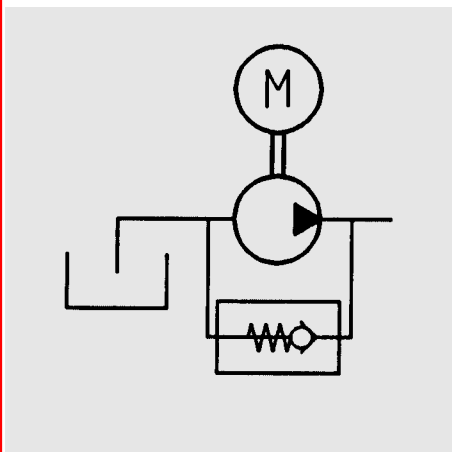

2. DESCRIPTION

2.1. DIAGRAMMATIC ILLUSTRATION

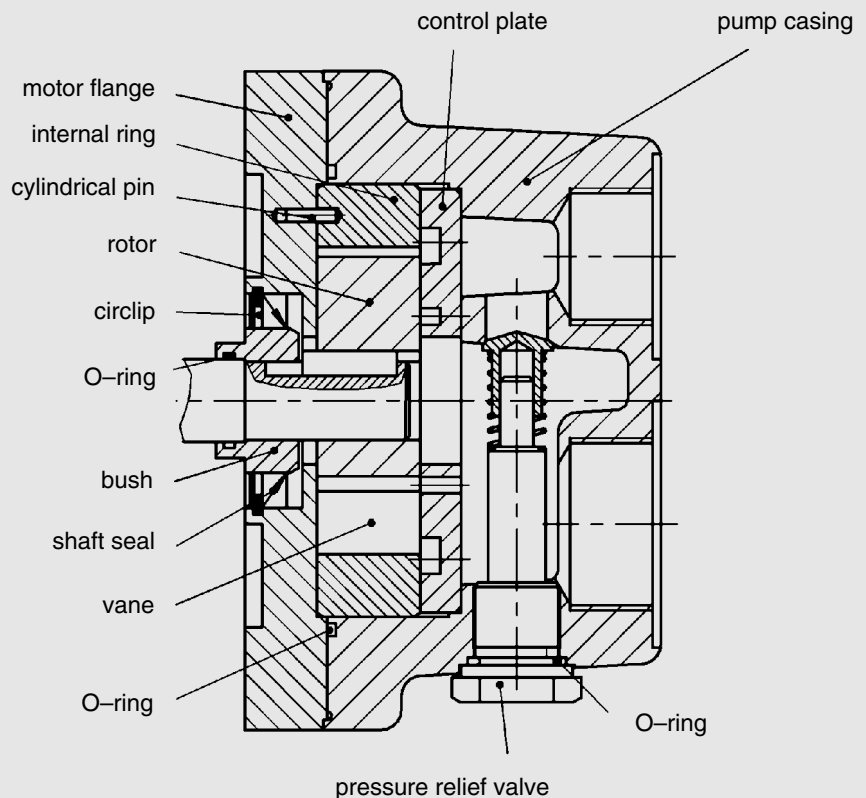

2.2. NOTES ON PIPING

Pressure differentials (flow rate losses)

-Simplified for hydraulic oils:

$$\Delta p [\text{bar}] = 5.84 \cdot \frac{l [\text{m}] \cdot Q [\text{l/min}] \cdot \gamma [\text{mm}^2/\text{s}]}{d^4 [\text{mm}]}$$

- Effect of the internal diameter on the flow rate losses using the following example values:

$$l = 1\text{m}; Q = 150 \text{ l/min}; \gamma = 200 \text{ mm}^2/\text{s}$$

	Internal diameter (mm)		
	di ₁ (38)	di ₁ (32)	di ₁ (25)
Δp (bar/m)	0.084	0.167	0.45

- Only applicable for straight pipes
- Additional threaded connections and pipe bends increase the flow rate losses

Note: - as few threaded connections as possible
 - few pipe bends; if required use large radius
 - difference in height between pump and oil level as small as possible
 - hoses must be suitable for a vacuum of min. 5000 mmW (e.g. hoses to be steel reinforced)
 - do not reduce piping cross-section predetermined by the threaded connection.

3. MODEL CODE

MFZP-2 / 2.1 / P / 90/40 / RV6 / 1.5/400-50

Motor/pump unit
(with motor)

MFZP

Direct drive pump

FZP

Size

1
2
3

Modification number

(see table for flow rates)

Seals = P (Perbunan)

(other materials on request)

Motor size and flow rate

Size	Motor size	Modification number	Flow rates in ccm/revolutions (others on request)								
			3.5	7	10	20	30	40	70	100	130
1	63 (0.18 kW, only MFZP)	2.0	●	●	●						
	AMG (0.2 kW, DC)	1.1	●	●	●						
	71 (0.37 kW)	1.1	●	●	●						
2	80 (0.75 kW)	2.1				●	●	●			
	90 (1.5 kW)	2.1				●	●	●			
3	100 (2.2 kW)	3.0							●	●	●
	100 (4.0 kW)	3.0							●	●	●

Pressure relief valve

RV3 (3.0 bar)

RV4.5 (4.5 bar)

RV6 (6.0 bar) (standard size)

Motor output and voltage (n=1500 rpm)

(other voltages and frequencies on request)

Size 1:

0.18 kW

0.2 kW/12 V or 24 V DC

0.37 kW

Size 2:

0.75 kW

1.5 kW

Size 3:

2.2 kW

4.0 kW

Standard voltages and frequencies for 3-phase motors

(dual voltage motor)

380-420 V star / 220-240 V delta – 50 Hz

440-480 V star / 254-277 V delta – 60 Hz (motor output x 1.15)

4. TECHNICAL SPECIFICATIONS

- 4.1. OPERATING PRESSURE
6 bar max.
(higher pressures on request)
- 4.2. SUCTION PRESSURE ACROSS THE SUCTION CONNECTION
max.: -0.4 to 0.5 bar
- 4.3. FLUID
Mineral oil to DIN 51524
Part 1 and 2
Permissible contamination
≤ **NAS 12**
- 4.4. FLUID TEMPERATURE
-20 °C to +80 °C
for mineral oil
- 4.5. VISCOSITY
See graphs
- 4.6. AMBIENT TEMPERATURE
-20 °C to +40 °C
- 4.7. MOUNTING POSITION
Optional
- 4.8. REVOLUTIONS
Minimum 1000 rpm
Maximum 2000 rpm
DIRECTION OF ROTATION
Clockwise
(when looking at motor fan wheel)
- 4.9. WEIGHTS
FZP-1: 1.4 kg
FZP-2: 3.9 kg
FZP-3: 9.6 kg
MFZP-1/2.0/... 0.18 kW: 6.0 kg
MFZP-1/1.1/... 0.37 kW: 7.4 kg
MFZP-1/1.1/... 0.2 kW-DC: 9.0 kg
MFZP-2/2.1/... 0.75 kW: 13.5 kg
MFZP-2/2.1/... 1.5 kW: 19.5 kg
MFZP-3/3.0/... 2.2 kW: 32.5 kg
MFZP-3/3.0/... 4.0 kW: 39.5 kg
- 4.10. DRIVE
(only MFZP)
Type of drive: electric motor
Type of current:
three-phase; direct current
(only MFZP-1)
Output and voltage:
see model code
Protection class:
Three phase current: IP 55
Direct current: IP 65
Insulation class: F
- 4.11. VOLUMETRIC EFFICIENCY
> 90 % (at $v = 40 \text{ mm}^2/\text{s}$)

4.12. NOISE LEVELS

	ccm/ rev	1 bar	6 bar
Size 1	3.5	58	62 dB(A)
	7	58	63
	10	60	64
Size 2	20	66	68
	30	67	68
	40	69	70
Size 3	70	69	71
	100	76	78
	130	77	78

Test fluid:
ISOVG46 at 40 °C (40 mm²/s)
The noise levels are only a guide
as acoustic properties of a room,
connections, viscosity and
reflections have an effect on the
noise level.

4.13. EXAMPLE

Selection of a pump (FZP) or
motor pump unit (MFZP)
according to customer's
parameters:

Flow rate: 190 l/min
Counter pressure: 5 bar
Viscosity: 200 cSt.
Motor voltage: 400 V 50 Hz

Selection:
190 l/min ⇒ FZP or MFZP-3
approx. 130 ccm/rev at
1500 rpm.
5 bar and 200 cSt ⇒
drive output 4 KW
Type:
FZP-3/3.0/P/100/130/RV6
Type:
MFZP-3/3.0/P/100/130/RV6/
4/400-50

4.14. GRAPHS (n = 1500 1/min) FZP-1

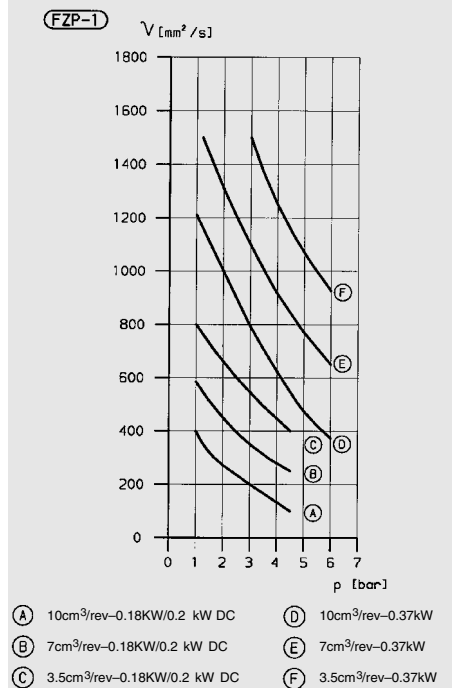

FZP-2

(FZP-2)

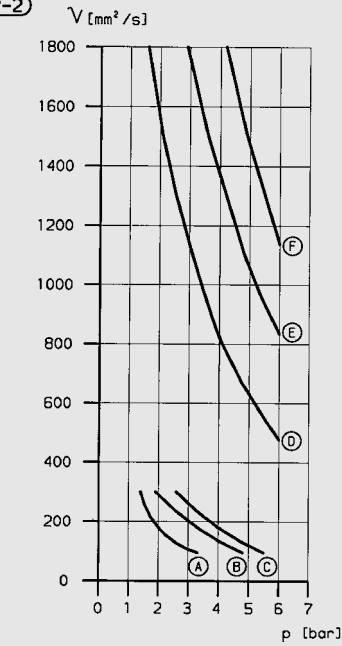

- | | |
|----------------------|---------------------|
| (A) 40cm³/rev-0.75KW | (D) 40cm³/rev-1.5kW |
| (B) 30cm³/rev-0.75KW | (E) 30cm³/rev-1.5kW |
| (C) 20cm³/rev-0.75KW | (F) 20cm³/rev-1.5kW |

4.15. VISCOSITY/TEMPERATURE GRAPH

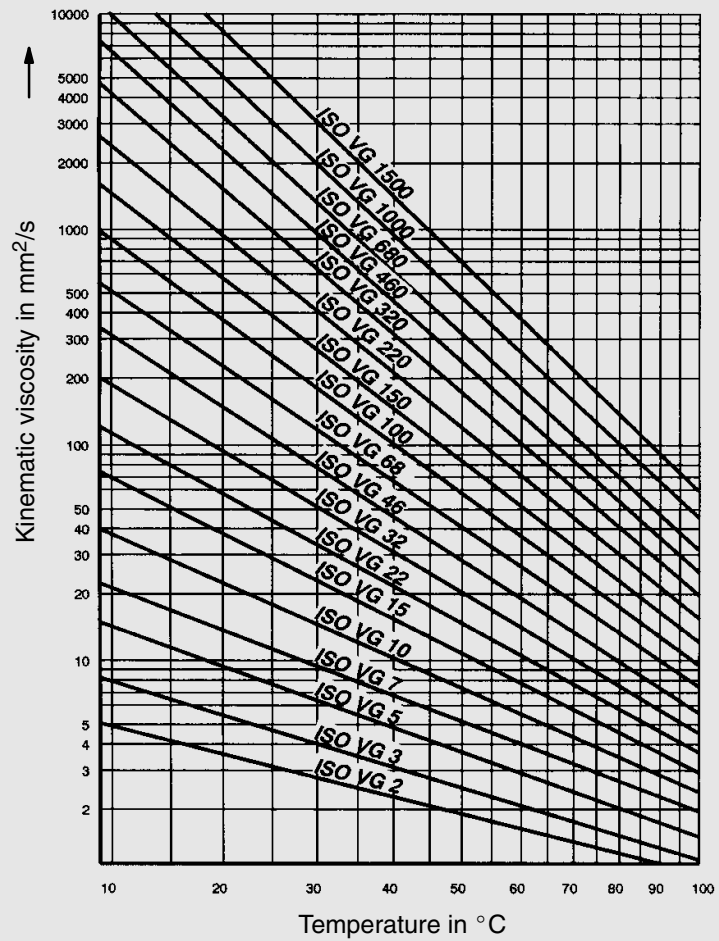

FZP-3

(FZP-3)

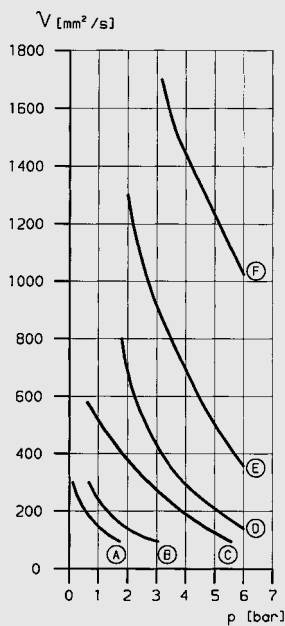

- | | |
|----------------------|----------------------|
| (A) 130cm³/rev-2.2KW | (D) 130cm³/rev-4.0kW |
| (B) 100cm³/rev-2.2KW | (E) 100cm³/rev-4.0kW |
| (C) 70cm³/rev-2.2KW | (F) 70cm³/rev-4.0kW |

4.16. POWER FACTOR

Power factor $\alpha = f(v)$

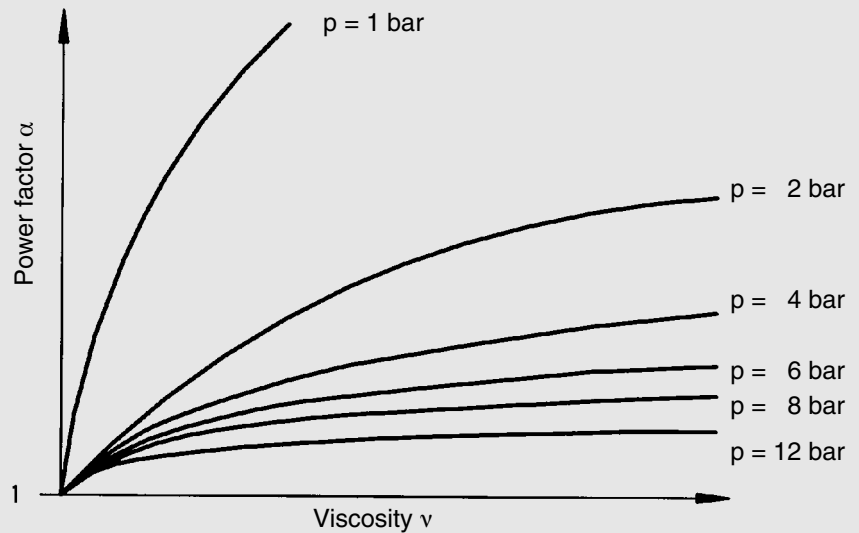

$$P_{hydr} = \dot{V} \times p$$

In order to determine the required drive power, the relationship between the operating pressure and viscosity must be taken into consideration.

The power correction factor increases as the viscosity increases and as the operating pressure decreases.

$$P = P_{hydr} \times \alpha$$

5. DIMENSIONS

Direct drive vane pumps

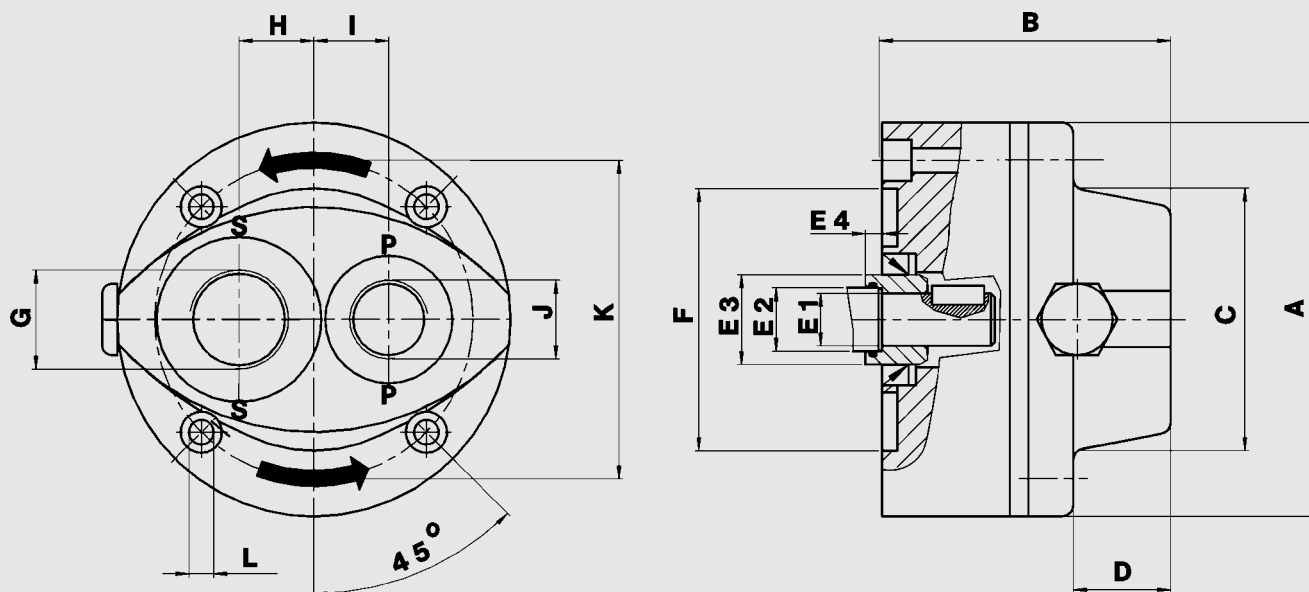

Size	Flow rate l/min at n = 1500 1/min	Pump dimensions														
		A	B	C	D	E1	E2	E3	E4	F	G	H	I	J	K	L
1	5 – 15	105	75	70	26	14	17	24	5	70	G 3/4	20	20	G 1/2	85	7
2	30 – 60	160	100	100	33	19	20	35	7	110	G 1 1/4	30	35	G 1	130	9
						24	25	35	7							
3	100–200	200	130	140	35	28	30	40	7	130	G 2	43.75	43.75	G 1 1/2	165	11

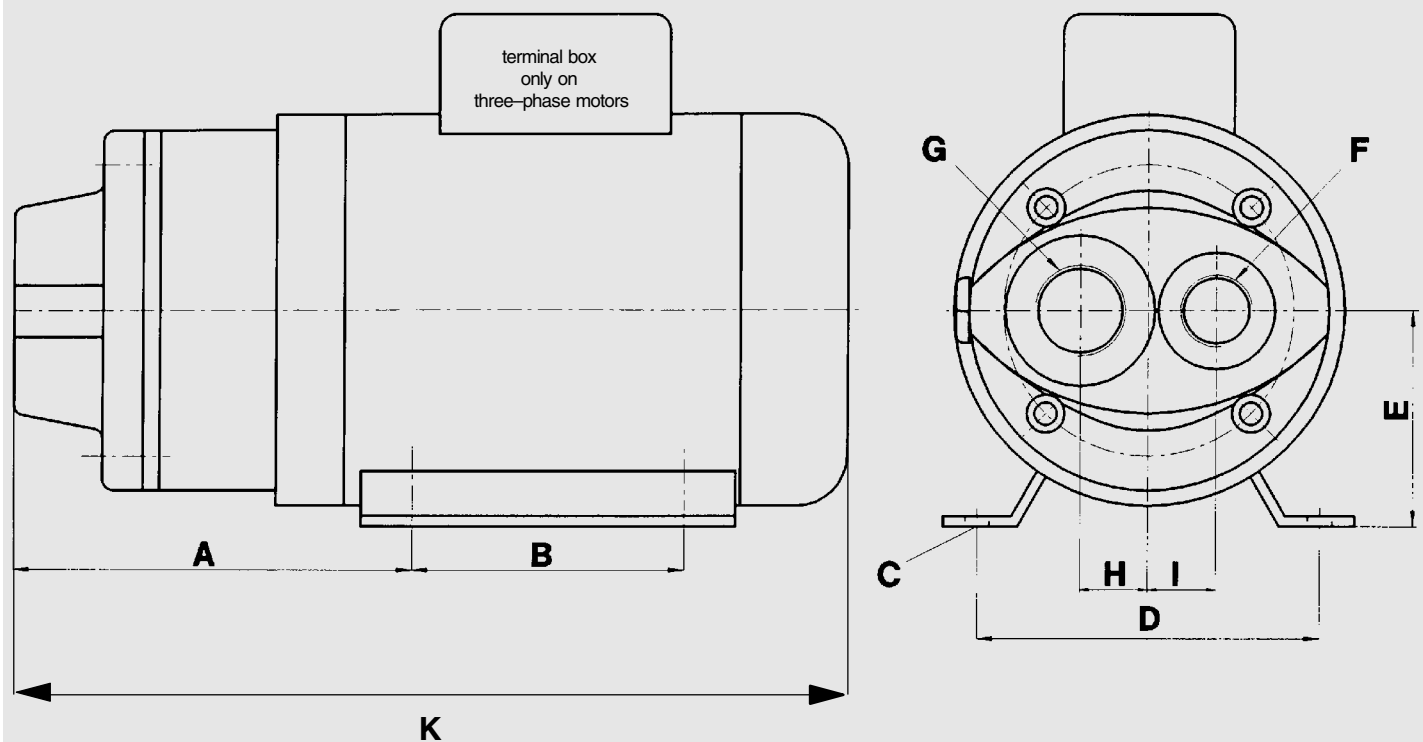

	A	B	C	D	E	F	G	H	I
MFZP-1/2.0/X/63	117	80	7	100	63	G 1/2	G 3/4	20	20
MFZP-1/1.1/X/AMG	117	80	7	100	63	G 1/2	G 3/4	20	20
MFZP-1/1.1/X/71	120	90	7	112	71	G 1/2	G 3/4	20	20
MFZP-2/2.1/X/80	150	100	9	125	80	G 1	G 1 1/4	30	35
MFZP-2/2.1/X/90	156	125	9	140	90	G 1	G 1 1/4	30	35
MFZP-3/3.0/X/100	193	140	12	160	100	G 1 1/2	G 2	43.75	43.75

Lengths "K" of motor/pump units:

MFZP-1 with elec. motor size	63/0.18 kW/	spec. flange: approx. 260 mm
MFZP-1 with elec. motor size	AMG/0.2 kW/B34	small flange: approx. 245 mm
MFZP-1 with elec. motor size	71/0.37 kW/B34	small flange: approx. 320 mm
MFZP-2 with elec. motor size	80/0.75 kW/B34	large flange: approx. 340 mm
MFZP-2 with elec. motor size	90/1.5 kW/B34	large flange: approx. 380 mm
MFZP-3 with elec. motor size	100/2.2 kW/B34	large flange: approx. 450 mm
MFZP-3 with elec. motor size	100/4 kW/B34	large flange: approx. 480 mm

6. FEED PUMP SERIES KFZP

The KFZP pumps can be mounted directly onto motor flange B5. The friction bearing on the pump shaft allows pressure of up to 16 bar.

6.1. SPECIAL FEATURES

- pressure range up to 16 bar
- mounting thread for assembly on tanks or flat surfaces
- no coupling or bell housing required
- vane type pump with good volumetric efficiency (> 90 % at 40 mm²/s)
- friction bearing
- motor construction B5
size 1 + 2: size 71
size 3 + 4: size 90

6.2. APPLICATIONS

- filter circuits
- cooling circuits
- lubrication applications
- pump transfer units

7. DESCRIPTION

7.1. DIAGRAMMATIC ILLUSTRATION

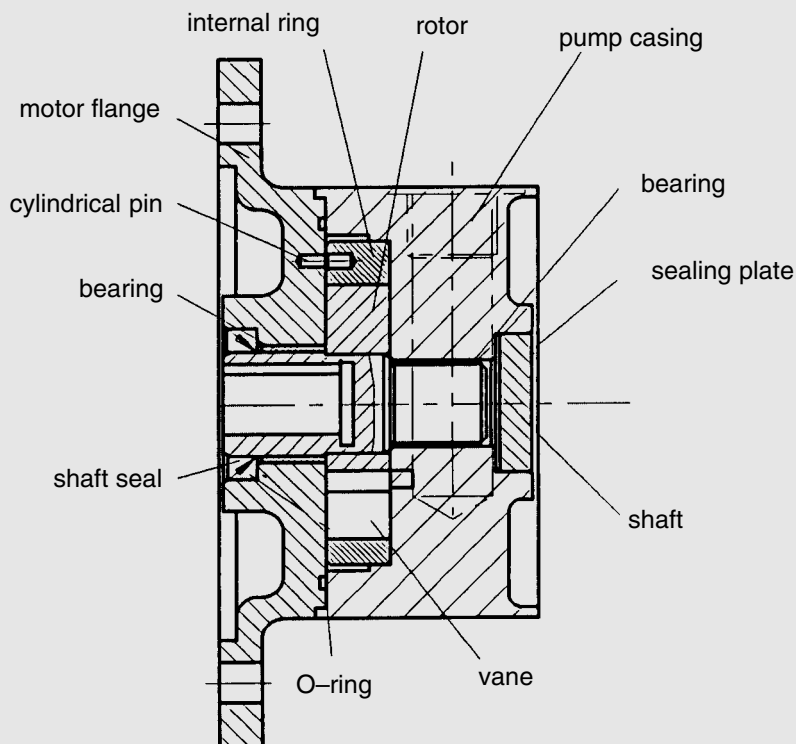

7.2. SYMBOL

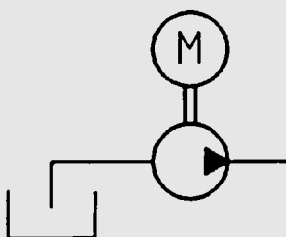

8. MODEL CODE

KFZP - 3+4 / 2.2 / P / 90 / 40

Direct drive pump _____

KFZP

Size _____

1 + 2

3 + 4

Modification number _____

Seal P = Perbunan _____

(other materials on request)

Motor connection and flow rate _____

Size	Motor connection Construction B5	Flow rates in ccm/revolutions				
		5	8	10	28	40
1 + 2	Size 71	●	●	●		
3 + 4	Size 90				●	●

9. TECHNICAL SPECIFICATIONS

- 9.1. OPERATING PRESSURE
16 bar max.
- 9.2. SUCTION PRESSURE
ACROSS THE SUCTION
CONNECTION
max. -0.4 to 0.5 bar
- 9.3. FLUID
Mineral oil to DIN 51524
Part 1 and 2
Permissible contamination
≤ **NAS 12**
- 9.4. FLUID TEMPERATURE
-20 °C to + 80 °C
for mineral oil
- 9.5. VISCOSITY
See graphs
- 9.6. AMBIENT TEMPERATURE
-20 °C to + 40 °C
- 9.7. MOUNTING POSITION
Optional
- 9.8. REVOLUTIONS
Minimum 1000 rpm
Maximum 2000 rpm
- 9.9. WEIGHTS
KFZP - 1 + 2: 1.9 kg
KFZP - 3 + 4: 4.2 kg
- 9.10. VOLUMETRIC EFFICIENCY
> 90 % (at $v = 40 \text{ mm}^2/\text{s}$)
- 9.11. NOISE LEVELS
KFZP - 1 + 2: 67 dB(A)
KFZP - 3 + 4: 73 dB(A)

9.12. GRAPHS

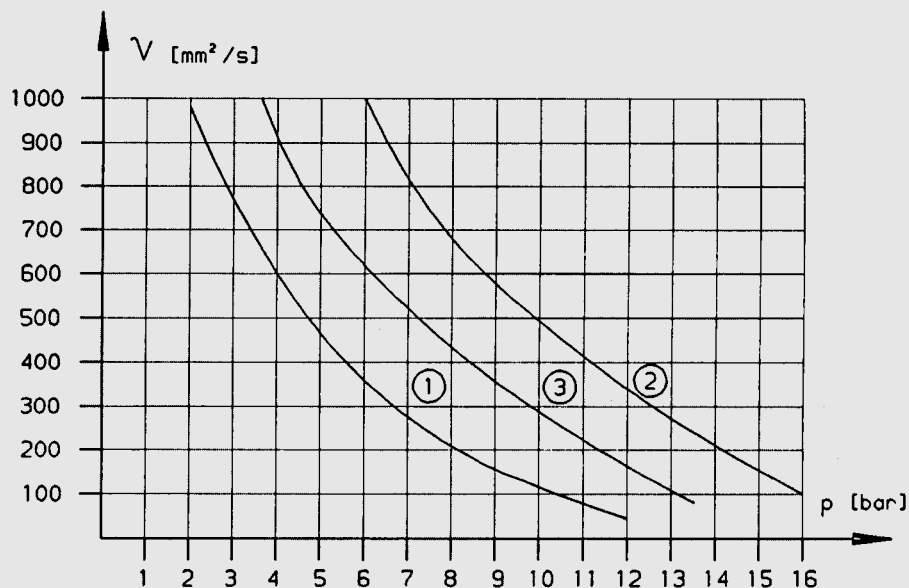

KFZP-1+2/2.2/P/71/10

KFZP-3+4/2.2/P/90/XX

① =10 ccm/rev; 0.37KW
1500min⁻¹

② =28 ccm/rev; 1.5KW
1500min⁻¹

③ =40ccm/rev; 1.5KW
1500min⁻¹

10. DIMENSIONS

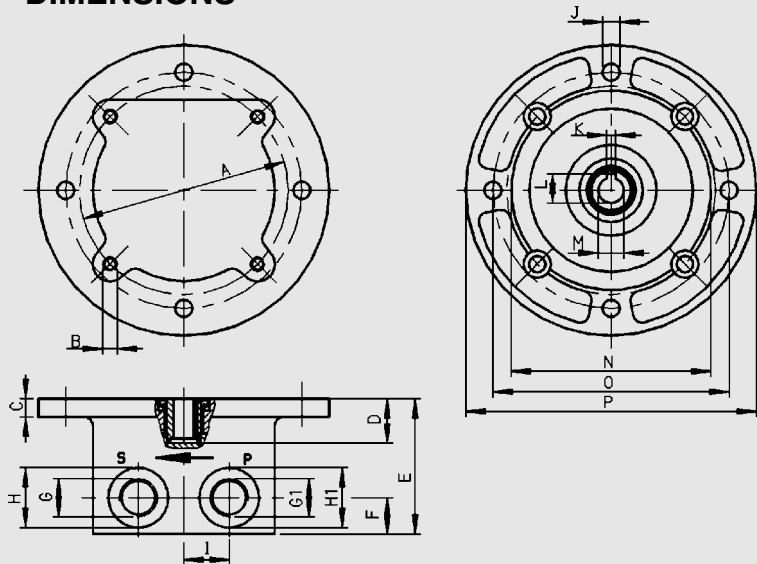

Dimension	A	B	C	D	E	F	G	G1
Size 1+2	115	M8	12	31	76.5	20	G $\frac{1}{2}$	G $\frac{1}{2}$
Size 3+4	140	M8	10	51	118.5	38	G 1 $\frac{1}{4}$	G1

Dimension	H	H1	I	J	K	L	M	N	O	P
Size 1+2	33	33	25	9.5	5	16	14	110	130	160
Size 3+4	60	50	32.5	11.5	8	27	24	130	165	200

11. NOTE

The information in this brochure relates to the operating conditions and applications described. For applications or operating conditions not described, please contact the relevant technical department. Subject to technical modifications.