

3300 XL 8 mm Proximity Transducer System

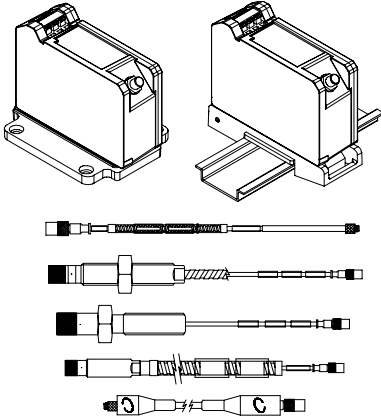

Description

Transducer System

The 3300 XL 8 mm Proximity Transducer System consists of:

- a 3300 XL 8 mm probe
- a 3300 XL extension cable
- a 3300 XL ProximitoR® Sensor¹

The system provides an output voltage directly proportional to the distance between the probe tip and the observed conductive surface. It is capable of both static (position) and dynamic (vibration) measurements, and is primarily used for vibration and position measurement applications on fluid-film bearing machines, as well as Keyphasor® and speed measurement applications².

The 3300 XL 8 mm system represents our most advanced performance in an eddy current proximity transducer system. The standard 3300 XL 8 mm 5 metre system is also 100% compliant with the American Petroleum Institute's (API) 670 Standard (4th Edition) for mechanical configuration, linear range, accuracy, and temperature stability. All 3300 XL 8 mm Proximity Transducer Systems achieve this level of performance while allowing complete interchangeability of probe, extension cable, and ProximitoR® Sensor without the need for individual component matching or bench calibration.

Each component of the 3300 XL 8 mm Transducer System is backward compatible and interchangeable³ with other non-XL 3300 series 5 and 8 mm transducer system components⁴. This includes the 3300 5 mm probe, which is used when an 8 mm probe is too large for the available mounting space^{5,6}.

ProximitoR® Sensor

The 3300 XL ProximitoR® Sensor incorporates numerous improvements over previous designs. Its physical packaging permits high-density DIN-rail installation. It can also be mounted in a traditional panel mount configuration, where it shares an identical "footprint" to older 4-hole mounted ProximitoR® Sensor designs. The mounting base for either option provides electrical isolation, eliminating the need for separate isolator plates. The 3300 XL ProximitoR® Sensor is highly immune to radio frequency interference, allowing installation in fiberglass housings without adverse effects from nearby radio frequency signals. Improved RFI/EMI immunity allows the 3300 XL ProximitoR® Sensor to achieve European CE mark approvals without requiring special shielded conduit or metallic housings, resulting in lower installation costs and complexity.

The 3300 XL's SpringLoc terminal strips require no special installation tools and facilitate faster, more robust field wiring connections by eliminating screw-type clamping mechanisms that can loosen.



**Total System
Mass (typical):**

0.7 kg (1.5 lbm)

Probe:

323 g (11.38 oz)

Extension Cable:

34 g/m (0.4 oz/ft)

*Armored Extension
cable:*

103 g/m (1.5 oz/ft)

*Proximito[®]
Sensor:*

246 g (8.7 oz)

Environmental Limits

Probe Temperature Range

*Operating and
Storage*

*Temperature:
Standard
probe:*

-51 °C to +177 °C (-60 °F to +351 °F)

*Extended
Temperature
Range probe:*

-51 °C to +177 °C (-60 °F to +351 °F) for the probe tip; -51 °C to +260 °C (-60 °F to +500 °F) for the probe cable and connector.

Note: Exposing the probe to temperatures below -34 °C (-30 °F) may cause premature failure of the pressure seal.

Extension Cable Temperature Range

Operating and Storage Temperature:

Standard cable:

-51 °C to +177 °C (-60 °F to +351 °F)

*Extended
Temperature
Range cable:*

-51 °C to +260 °C (-60 °F to +500 °F)

Proximito[®] Sensor Temperature Range

*Operating
Temperature:*

-51 °C to +100 °C (-60 °F to +212 °F)

*Storage
Temperature:*

-51 °C to +105 °C (-60 °F to +221 °F)

Relative Humidity:

Less than a 3% change in Average Scale Factor (ASF) when tested in 93% humidity in accordance with IEC standard 68-2-3 for up to 56 days.

Probe Pressure:

3300 XL 8 mm probes are designed to seal differential pressure between the probe tip and case. The probe sealing material consists of a Viton[®] O-ring. Probes are not pressure tested prior to shipment. Contact our custom design department if you require a test of the pressure seal for your application.

Note: It is the responsibility of the customer or user to ensure that all liquids and gases are contained and safely controlled should leakage occur from a proximity probe. In addition, solutions with high or low pH values may erode the tip assembly of the probe causing media leakage into surrounding areas. Bently Nevada[®], LLC will not be held responsible for any damages resulting from leaking 3300 XL 8 mm proximity probes. In addition, 3300 XL 8 mm proximity probes will not be replaced under the service plan due to probe leakage.

Patents:

5,016,343;
5,126,664;
5,351,388, and
5,685,884.

Components or procedures described in these patents apply to this product.

Ordering Information

3300 XL 8 mm Proximity Probes:

330101 3300 XL 8 mm Probe, 3/8-24 UNF thread, without armor³

330102 3300 XL 8 mm Probe, 3/8-24 UNF thread, with armor³

Part Number-AXX-BXX-CXX-DXX-EXX

Option Descriptions

A: Unthreaded Length Option

Note: Unthreaded length must be at least 0.8 inches less than the case length.

Order in increments of 0.1 in

Length configurations:

Maximum unthreaded length: 8.8 in

Minimum unthreaded length: 0.0 in

3300 XL Extension Cable

330130-AXXX-BXX-CXX

Note: Make sure that the extension cable length and the probe length, when added together, equal the Proximitor® Sensor total length.

Option Descriptions

A: Cable Length Option

- 0 3 0 3.0 metres (9.8 feet)
- 0 3 5 3.5 metres (11.5 feet)
- 0 4 0 4.0 metres (13.1 feet)
- 0 4 5 4.5 metres (14.8 feet)
- 0 7 0 7.0 metres (22.9 feet)
- 0 7 5 7.5 metres (24.6 feet)
- 0 8 0 8.0 metres (26.2 feet)
- 0 8 5 8.5 metres (27.9 feet)

B: Connector Protector and Cable Option

- 0 0 Standard cable
- 0 1 Armored cable
- 0 2 Standard cable with connector protectors
- 0 3 Armored cable with connector protectors
- 1 0 FluidLoc® cable
- 1 1 Armored FluidLoc® cable
- 1 2 FluidLoc® cable with connector protectors
- 1 3 Armored FluidLoc® cable with connector protectors

C: Agency Approval Option

- 0 0 Not required
- 0 5 Multiple Approvals

3300 XL Extended Temperature Range (ETR) Extension Cable

330190-AXXX-BXX-CXX

Note: Make sure that the extension cable length and the probe length, when added together, equal the Proximitor® Sensor total length.

Option Descriptions

A: Cable Length Option

- 0 3 0 3.0 metres (9.8 feet)
- 0 3 5 3.5 metres (11.5 feet)
- 0 4 0 4.0 metres (13.1 feet)

- 0 4 5 4.5 metres (14.8 feet)
- 0 7 0 7.0 metres (22.9 feet)
- 0 7 5 7.5 metres (24.6 feet)
- 0 8 0 8.0 metres (26.2 feet)
- 0 8 5 8.5 metres (27.9 feet)

B: Cable Option

- 0 0 Standard cable
- 0 1 Armored cable

C: Agency Approval Option

- 0 0 Not required
- 0 5 Multiple Approvals

Accessories

141078-01

Manual

159484

Performance Specification – 3300 XL Proximity Transducer System

162735

Performance Specification – 3300 XL ETR probes and extension cables

02120015

Bulk field wire. 1.0 mm² (18 AWG), 3 conductor, twisted, shielded cable with drain wire. Specify length in feet.

137491-AXX

Aluminum probe clamp bracket²

Option Descriptions

A: Mounting screw option

- 0 1 10-24 UNC-2A mounting screws
- 0 2 M5 x 0.8-6g mounting screws

The aluminum clamp bracket is an unthreaded mounting bracket designed to use with the smooth case probes (330140, 330141, 330197 and 330198). After gapping the probe, tighten the clamp bracket by tightening the screws. The mounting screws have pre-drilled holes for safety wire.

137492-AXX

Aluminum probe threaded mounting bracket

Option Descriptions

A: Thread size

- 0 1 3/8-24
- 0 4 M10 x 1

The aluminum probe threaded mounting bracket is the standard mounting bracket for most 3300 and 3300 XL probe