

# Supply Systems

313527ZAK

EN

*For transferring or dispensing sealants, adhesives, or other medium to high viscosity fluids. For professional use only.*

## L20c 2 inch single post elevator

20 liter (5 gallon) size  
100 psi (0.7 MPa, 7 bar) Maximum Air Inlet Pressure

## S20 3 inch single post

20 liter (5 gallon) size  
125 psi (0.9 MPa, 9 bar) Maximum Air Inlet Pressure

## D60 3 inch dual post

60 liter (16 gallon) size  
150 psi (1.0 MPa, 10 bar) Maximum Air Inlet Pressure

## D200 3 inch dual post

200 liter (55 gallon), 115 liter (30 gallon),  
60 liter (16 gallon) size, 30 liter (8 gallon),  
20 liter (5 gallon) sizes  
150 psi (1.0 MPa, 10 bar) Maximum Air Inlet Pressure

## D200S 6.5 inch dual post

200 liter (55 gallon), 115 liter (30 gallon)  
125 psi (0.9 MPa, 9 bar) Maximum Air Inlet Pressure

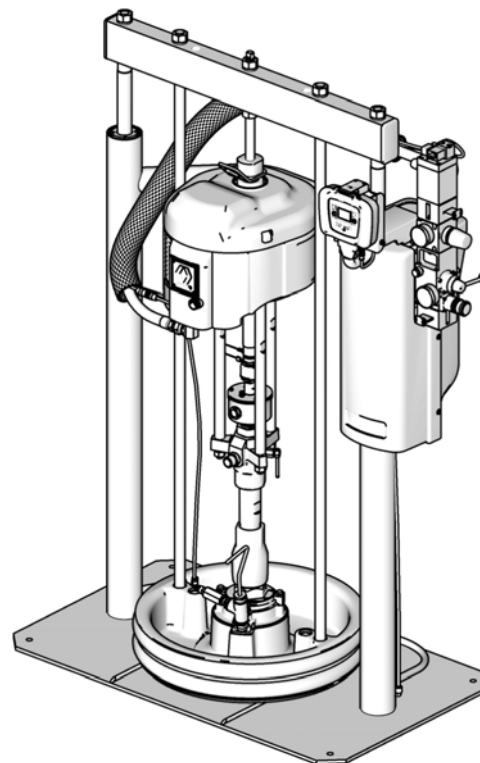


### Important Safety Instructions

Read all warnings and instructions in this manual.  
Save these instructions.

See page 6 for model information and approvals.

*The Graco Control Architecture Electric Components  
are Listed in Intertek's Directory of Listed Products.*



D200 CM14BA

Ti10429A

# Table of Contents






<b>Related Manuals</b> .....	<b>3</b>	<b>L20c Supply Systems Point of Operation</b>	
<b>Warnings</b> .....	<b>4</b>	<b>Instructions</b> .....	<b>39</b>
<b>Models</b> .....	<b>6</b>	Start and Adjust Ram .....	39
<b>Component Identification</b> .....	<b>10</b>	Start and Adjust Pump .....	40
D200 3 in. and D200s 6.5 in. Dual Post .....	10	Change Drums .....	40
S20 3 in. Single Post and D60 3 in. Dual Post ..	11	<b>Technical Data</b> .....	<b>42</b>
L20c 2in. Elevator .....	13	<b>Graco Standard Warranty</b> .....	<b>44</b>
L20c 2 in. Air Controls .....	14		
<b>Installation</b> .....	<b>15</b>		
General Information .....	15		
Location .....	15		
Grounding .....	15		
Mechanical Setup .....	16		
Connect Remote DataTrak to Power .....	16		
Attach and Adjust Drum Low/Empty Sensor ...	17		
Light Tower Accessory .....	17		
Attach Drum Stops .....	18		
<b>Supply System Operation</b> .....	<b>19</b>		
Pressure Relief Procedure .....	19		
Flush Before Using Equipment .....	19		
Start and Adjust Ram .....	19		
Start and Adjust Pump .....	21		
Change Drums .....	21		
Shutdown and Care of the Pump .....	22		
Replace Throat Seals .....	22		
Remote DataTrak Setup .....	23		
<b>Remote DataTrak Controls and Indicators</b> .....	<b>24</b>		
<b>Remote DataTrak Operation</b> .....	<b>25</b>		
Startup .....	25		
Run Mode .....	25		
Prime Mode .....	26		
Setup Mode .....	26		
Diagnostic Mode .....	29		
<b>Dimensions</b> .....	<b>34</b>		
<b>Schematic</b> .....	<b>36</b>		
Remote DataTrak, Light Tower, Drum Low/Empty Sensor .....	36		
<b>D200S, D200, S20, and D60 Supply Systems</b>			
<b>Point of Operation Instructions</b> .....	<b>37</b>		
Start and Adjust Ram .....	37		
Start and Adjust Pump .....	38		
Change Drums .....	38		
Remote DataTrak Operation .....	38		

## Related Manuals

The following manuals are available at [www.graco.com](http://www.graco.com).





Manual in English	Description
313526	Supply Systems Operation
313528	Tandem Supply Systems Operation
313529	Tandem Supply Systems Repair-Parts
312375	Check-Mate <sup>®</sup> Displacement Pumps Instructions-Parts
312376	Check-Mate <sup>®</sup> Pump Packages Instruction-Parts
311827	Dura-Flo <sup>™</sup> Displacement Pumps (145cc, 180cc, 220cc, 290cc) Instructions-Parts Manual
311825	Dura-Flo <sup>™</sup> Displacement Pumps (430cc, 580cc) Instructions-Parts Manual
311717	Carbon Steel Displacement Pump (1000cc) Instructions-Parts Manual
311828	Dura-Flo <sup>™</sup> Pump Packages (145cc, 180cc, 220cc, 290cc) Instructions-Parts Manual
311826	Dura-Flo <sup>™</sup> Pump Packages (430cc, 580cc) Instructions-Parts Manual
311833	Two-Ball NXT <sup>™</sup> Pump Packages (1000cc) Instructions-Parts Manual
312889	60 cc Check-Mate Displacement Pump Repair Parts Manual
312467	100 cc Check-Mate Displacement Pump Repair Parts Manual
312468	200 cc Check-Mate Displacement Pump Repair Parts Manual
312469	250 cc Check-Mate Displacement Pump Repair Parts Manual
312470	500 cc Check-Mate Displacement Pump Repair Parts Manual
311238	NXT <sup>™</sup> Air Motor (Nxxxxx models) Instructions-Parts
312796	NXT <sup>™</sup> Air Motor (Mxxxxx models) Instructions-Parts
312374	Air Controls Instructions-Parts
312491	Pump Fluid Purge Kit
312492	Drum Roller Kit Instruction
312493	Light Tower Kit Instruction
406681	Platen Cover Kit
334048	EPDM Hose Wiper Kit
334644	Xtreme <sup>®</sup> XL Air Motor, Instructions-Parts

# Warnings

 <b>WARNING</b>	
	<p><b>SKIN INJECTION HAZARD</b></p> <p>High-pressure fluid from gun, hose leaks, or ruptured components will pierce skin. This may look like just a cut, but it is a serious injury that can result in amputation. <b>Get immediate surgical treatment.</b></p> <ul style="list-style-type: none"> <li>• Do not point gun at anyone or at any part of the body.</li> <li>• Do not put your hand over the dispense outlet.</li> <li>• Do not stop or deflect leaks with your hand, body, glove, or rag.</li> <li>• Follow <b>Pressure Relief Procedure</b> in this manual, when you stop dispensing and before cleaning, checking, or servicing equipment.</li> </ul>
	<p><b>MOVING PARTS HAZARD</b></p> <p>Moving parts can pinch or amputate fingers and other body parts.</p> <ul style="list-style-type: none"> <li>• Keep clear of moving parts.</li> <li>• Do not operate equipment with protective guards or covers removed.</li> <li>• Pressurized equipment can start without warning. Before checking, moving, or servicing equipment, follow the <b>Pressure Relief Procedure</b> in this manual. Disconnect power or air supply.</li> </ul>
	<p><b>FIRE AND EXPLOSION HAZARD</b></p> <p>Flammable fumes, such as solvent and paint fumes, in <b>work area</b> can ignite or explode. To help prevent a fire and explosion:</p> <ul style="list-style-type: none"> <li>• Use equipment only in well ventilated area.</li> <li>• Eliminate all ignition sources; such as pilot lights, cigarettes, portable electric lamps, and plastic drop cloths (potential static arc).</li> <li>• Keep work area free of debris, including solvent, rags and gasoline.</li> <li>• Do not plug or unplug power cords, or turn power or light switches on or off when flammable fumes are present.</li> <li>• Ground all equipment in the work area. See <b>Grounding</b> instructions.</li> <li>• Use only grounded hoses.</li> <li>• Hold gun firmly to side of grounded pail when triggering into pail.</li> <li>• If there is static sparking or you feel a shock, <b>stop operation immediately</b>. Do not use equipment until you identify and correct the problem.</li> <li>• Keep a working fire extinguisher in the work area.</li> </ul>
	<p><b>EQUIPMENT MISUSE HAZARD</b></p> <p>Misuse can cause death or serious injury.</p> <ul style="list-style-type: none"> <li>• Do not operate the unit when fatigued or under the influence of drugs or alcohol.</li> <li>• Do not exceed the maximum working pressure or temperature rating of the lowest rated system component. See <b>Technical Data</b> in all equipment manuals.</li> <li>• Do not leave the work area while equipment is energized or under pressure. Turn off all equipment and follow the <b>Pressure Relief Procedure</b> in this manual when equipment is not in use.</li> <li>• Check equipment daily. Repair or replace worn or damaged parts immediately with genuine manufacturer's replacement parts only.</li> <li>• Do not alter or modify equipment.</li> <li>• Use equipment only for its intended purpose. Call your distributor for information.</li> <li>• Route hoses and cables away from traffic areas, sharp edges, moving parts, and hot surfaces.</li> <li>• Do not kink or over bend hoses or use hoses to pull equipment.</li> <li>• Keep children and animals away from work area.</li> <li>• Comply with all applicable safety regulations.</li> </ul>



# WARNING

	<p><b>ELECTRIC SHOCK HAZARD</b></p> <p>This equipment must be grounded. Improper grounding, setup, or usage of the system can cause electric shock.</p> <ul style="list-style-type: none"> <li>• Turn off and disconnect power cord before servicing equipment.</li> <li>• Use only grounded electrical outlets.</li> <li>• Use only 3-wire extension cords.</li> <li>• Ensure ground prongs are intact on power and extension cords.</li> <li>• Do not expose to rain. Store indoors.</li> </ul>
	<p><b>SPLATTER HAZARD</b></p> <p>Hot or toxic fluid can cause serious injury if splashed in the eyes or on skin. During blowoff of platen splatter may occur.</p> <ul style="list-style-type: none"> <li>• Use minimum air pressure when removing platen from drum.</li> </ul>
	<p><b>TOXIC FLUID OR FUMES HAZARD</b></p> <p>Toxic fluids or fumes can cause serious injury or death if splashed in the eyes or on skin, inhaled, or swallowed.</p> <ul style="list-style-type: none"> <li>• Read MSDS's to know the specific hazards of the fluids you are using.</li> <li>• Store hazardous fluid in approved containers, and dispose of it according to applicable guidelines.</li> <li>• Always wear impervious gloves when spraying or cleaning equipment.</li> </ul>
	<p><b>PERSONAL PROTECTIVE EQUIPMENT</b></p> <p>You must wear appropriate protective equipment when operating, servicing, or when in the operating area of the equipment to help protect you from serious injury, including eye injury, inhalation of toxic fumes, burns, and hearing loss. This equipment includes but is not limited to:</p> <ul style="list-style-type: none"> <li>• Protective eyewear</li> <li>• Clothing and respirator as recommended by the fluid and solvent manufacturer</li> <li>• Gloves</li> <li>• Hearing protection</li> </ul>

# Models

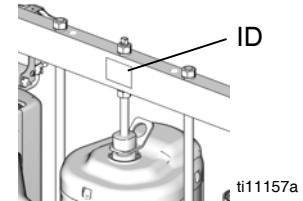
Check the identification plate (ID) for the 6-digit part number of the supply system. Use the following matrix to define the construction of the supply system, based on the six digits. For example, Part No. **CM14BA** represents a Check-Mate supply system (**CM**), a carbon steel Check-Mate 100 MaxLife<sup>®</sup> displacement pump with an NXT 2200 air motor with remote DataTrak (pump code **14**), a 3 in. dual post ram with integrated air controls (**B**) and a 55-gallon, uncoated platen with a neoprene seal (**A**).

### NOTICE

To prevent damage to DataTrak soft key buttons, do not press the buttons with sharp objects such as pens, plastic cards, or fingernails.

**NOTE:** Systems with the **GD** as the first and second digits are Dura-Flo supply systems.

Some configurations in the following matrix cannot be built. See the Product Selection Guide for available systems



To order replacement parts, see **Parts** section in manual 313527. The digits in the matrix on the next page do not correspond to the Ref. Nos. in the Parts drawings and lists.

All supply systems with DataTrak and 24 VDC or 100-240 VAC power supplies are ETL approved.



<b>CM</b>	<b>14</b>	<b>B</b>					<b>A</b>				
<b>First and Second Digit</b>	<b>Third and Fourth Digit</b>	<b>Fifth Digit</b>					<b>Sixth Digit</b>				
		<b>Ram Options</b>					<b>Platen and Seal Options</b>				
	<b>Pump Code</b>	<b>Size</b>	<b>Style</b>	<b>DataTrak Voltage</b>	<b>Air Controls</b>		<b>Platen Size</b>	<b>Platen Style</b>	<b>Platen Material</b>	<b>Seal Material</b>	
<b>CM</b> (Supply System with Check-Mate displacement pump)	(See Table 1 for 2-digit Check-Mate Pump Code)	<b>1</b>	2 in.	L20c	no volt	Air Control Panel	<b>B</b>	20 L (5 Gal)	F, SW	CS	Nitrile
		<b>2</b>	3 in.	S20c	no volt	INT	<b>C</b>	20 L (5 Gal)	F, SW	CS	Polyurethane
		<b>3</b>	3 in.	S20	no volt	INT	<b>F</b>	20 L (5 Gal)	F, SW	SST	PTFE coated Nitrile
		<b>4</b>	3 in.	D60	no volt	INT	<b>G</b>	20 L (5 Gal)	F, DW	CS	Nitrile
		<b>5</b>	3 in.	D200	no volt	INT	<b>H</b>	20 L (5 Gal)	F, DW	CS	Polyurethane
		<b>6</b>	3 in.	D200i	no volt	2-Button Interlock	<b>P</b>	20 L (5 Gal)	F, SW	CS	PVC
		<b>7</b>	6.5 in.	D200s	no volt	INT	<b>J</b>	30 L (8 Gal)	F, SW	CS	Nitrile
		<b>8</b>	6.5 in.	D200si	no volt	2-Button Interlock	<b>K</b>	30 L (8 Gal)	F, SW	CS	Polyurethane
		<b>9</b>	3 in.	D200	24 VDC	INT	<b>L</b>	30 L (8 Gal)	F, SW	SST	PTFE coated Nitrile
		<b>A</b>	3 in.	D200i	24 VDC	2-Button Interlock	<b>M</b>	30 L (8 Gal)	F, DW	CS	Nitrile
		<b>B</b>	3 in.	D200	100-240 VAC	INT	<b>R</b>	30 L (8 Gal)	F, DW	CS	Polyurethane
		<b>C</b>	3 in.	D200i	100-240 VAC	2-Button Interlock	<b>S</b>	60 L (16 Gal)	F, SW	CS	Nitrile
		<b>GD</b> (Supply System with Dura-Flo displacement pump)	(See Table 2 for 2-digit Dura-Flo Pump Code)	<b>F</b>	6.5 in.	D200s	24 VDC	INT	<b>T</b>	60 L (16 Gal)	F, SW
<b>G</b>	6.5 in.			D200si	24 VDC	2-Button Interlock	<b>U</b>	60 L (16 Gal)	F, SW	SST	PTFE coated Nitrile
<b>H</b>	6.5 in.			D200s	100-240 VAC	INT	<b>W</b>	60 L (16 Gal)	F, DW	CS	Nitrile
<b>J</b>	6.5 in.			D200si	100-240 VAC	2-Button Interlock	<b>Y</b>	60 L (16 Gal)	F, DW	CS	Polyurethane
<b>L</b>	3 in.			S20	100-240 VAC	INT	<b>7</b>	115 L 30 Gal	D	CS	EPDM
<b>M</b>	3 in.			S20	24 VDC	INT	<b>8</b>	200 L (55 Gal)	DR	PTFE coated AL	EPDM
<b>R</b>	3 in.			D60	100-240 VAC	INT	<b>9</b>	200 L (55 Gal)	DR	AL	EPDM
<b>T</b>	3 in.			D60i	100-240 VAC	2-Button Interlock	<b>A</b>	200 L (55 Gal)	DR	AL	Neoprene
<b>U</b>	3 in.			D60	24 VDC	INT	<b>D</b>	200 L (55 Gal)	DR	AL	EPDM Hose
<b>W</b>	3 in.			D60i	24 VDC	2-Button Interlock	<b>E</b>	200 L (55 gal)	DR	PTFE coated AL	Neoprene (small)
<b>Y</b>	3 in.			D60i	no volt	2-Button Interlock					

KEY:

S = Single post ram      i = 2-Button Interlock      F = Flat      SW = Single wiper  
 c = Cart mounted      s = 6.5 inch      D = D Style      DW = Double wiper  
 D = Dual post ram      INT = Integrated air controls      DR = Dual o-ring

\* Other Available Models: 262868. This model is the same as CM-\_\_-3-B models, such as CM-11-3-B, but uses Check-Mate Pump P40DCS (NXT2200/CM 100) instead of the other pumps listed on page 8.

Table 1: Check-Mate Pump Code/Part Index

Pump Code	Pump Part (see manual 312376)	Pump Code	Pump Part (see manual 312376)	Pump Code	Pump Part (see manual 312376)	Pump Code	Pump Part (see manual 312376)
<b>NXT 200/CM 60</b>		81	P38SCS	<b>NXT 2200/CM 200</b>		<b>NXT 6500/CM 250</b>	
4A	P05LCS	82	P38SCM	21	P23LCS	39	P55LCS
4B	P05LCM	83	P38SSS	22	P23LCM	3A	P55LCM
4C	P05LSS	84	P38SSM	23	P23RCS	3B	P55RCS
4F	P05LSM	<b>NXT 1800/CM 60</b>		24	P23RCM	3C	P55RCM
<b>NXT 400/CM 60</b>		9A	P61LCS	25	P23LSS	3F	P55LSS
6A	P11LCS	9B	P61LCM	26	P23LSM	3G	P55LSM
6B	P11LCM	9C	P61LSS	27	P23RSS	3H	P55RSS
6C	P11LSS	9F	P61LSM	28	P23RSM	3J	P55RSM
6F	P11LSM	9G	P61RCS	<b>NXT 3400/CM 200</b>		<b>Xtreme XL/CM 250</b>	
6G	P11RCS	9H	P61RCM	29	P36LCS	3L	P85LCS
6H	P11RCM	9J	P61RSS	2A	P36LCM	3M	P85LCM
6J	P11RSS	9K	P61RSM	2B	P36RCS	3R	P85LSS
6K	P11RSM	91	P61SCS	2C	P36RCM	3S	P85LSM
61	P11SCS	92	P61SCM	2F	P36LSS	<b>NXT 3400/CM 500</b>	
62	P11SCM	93	P61SSS	2G	P36LSM	51	P14LCS
63	P11SSS	94	P61SSM	2H	P36RSS	52	P14LCM
64	P11SSM	<b>NXT 2200/CM 100</b>		2J	P36RSM	53	P14RCS
<b>NXT 700/CM 60</b>		11	P40LCS	<b>NXT 6500/CM 200</b>		54	P14RCM
7A	P20LCS	12	P40LCM	2L	P68LCS	55	P14LSS
7B	P20LCM	1F	P40LSS	2M	P68LCM	56	P14LSM
7C	P20LSS	1G	P40LSM	2R	P68RCS	57	P14RSS
7F	P20LSM	13	P40RCS	2S	P68RCM	58	P14RSM
7G	P20RCS	14	P40RCM	2T	P68LSS	<b>NXT 6500/CM 500</b>	
7H	P20RCM	1H	P40RSS	2U	P68LSM	59	P26LCS
7J	P20RSS	1J	P40RSM	2W	P68RSS	5A	P26LCM
7K	P20RSM	10	P40SSS	2Y	P68RSM	5B	P26RCS
71	P20SCS	1A	P40SSM	20	P68SCS	5C	P26RCM
72	P20SCM	19	P40SCS	<b>NXT 3400/CM 250</b>		5F	P26LSS
73	P20SSS	<b>NXT 3400/CM 100</b>		31	P29LCS	5G	P26LSM
74	P20SSM	15	P63LCS	32	P29LCM	5H	P26RSS
<b>NXT 1200/CM 60</b>		16	P63LCM	33	P29RCS	5J	P26RSM
8A	P38LCS	1T	P63LSS	34	P29RCM	<b>Xtreme XL/CM 500</b>	
8B	P38LCM	1U	P63LSM	35	P29LSS	5L	P42LCS
8C	P38LSS	17	P63RCS	36	P29LSM	5M	P42LCM
8F	P38LSM	18	P63RCM	37	P29RSS	5R	P42LSS
8G	P38RCS	1W	P63RSM	38	P29RSM	5S	P42LSM
8H	P38RCM	1Y	P63RSM	<b>No Pump</b>			
8J	P38RSS	1B	P63SSS	NN			
8K	P38RSM	1C	P63SSM				

See manual 312375 or the ID plate on the pump to determine pump identification code.



Table 2: Dura-Flo Pump Identification Code/Part Index

Pump Code	Pump Part (see manual 311828)
<b>NXT 2200/DF 145SS</b>	
A1	P31LSS
<b>NXT 3400/DF 145SS</b>	
B1	P46LSS
<b>NXT 3400/DF 180SS</b>	
B5	P41LSS
<b>NXT 3400/DF 220SS</b>	
C1	P30LSS
<b>NXT 6500/DF 220SS</b>	
CA	P57LSS
<b>Xtreme XL/DF 290SS</b>	
DL	P71LSS

Pump Code	Pump Part (see manual 311826)
<b>NXT 3400/DF 430SS</b>	
E5	P15LSS
E6	P15LSM
<b>NXT 6500/DF 430SS</b>	
EF	P32LSS
EG	P32LSM
<b>Xtreme XL/DF 430</b>	
EL	P47LSS
EM	P47LSM
ES	P47LCM
ET	P47LCS
<b>NXT 3400/DF 580SS</b>	
F5	P12LSS
F6	P12LSM

Pump Code	Pump Part (see manual 311826)
<b>NXT 6500/DF 580CS</b>	
F9	P22LCS
<b>NXT 6500/DF 580SS</b>	
FF	P22LSS
FG	P22LSM
<b>Xtreme XL/DF 580CS</b>	
FL	P35LSS
FM	P35LSM
FT	P35LCS

Pump Code	Pump Part (see manual 311833)
<b>NXT 6500/DF 1000CS</b>	
G9	P10LCS

# Component Identification

## D200 3 in. and D200s 6.5 in. Dual Post

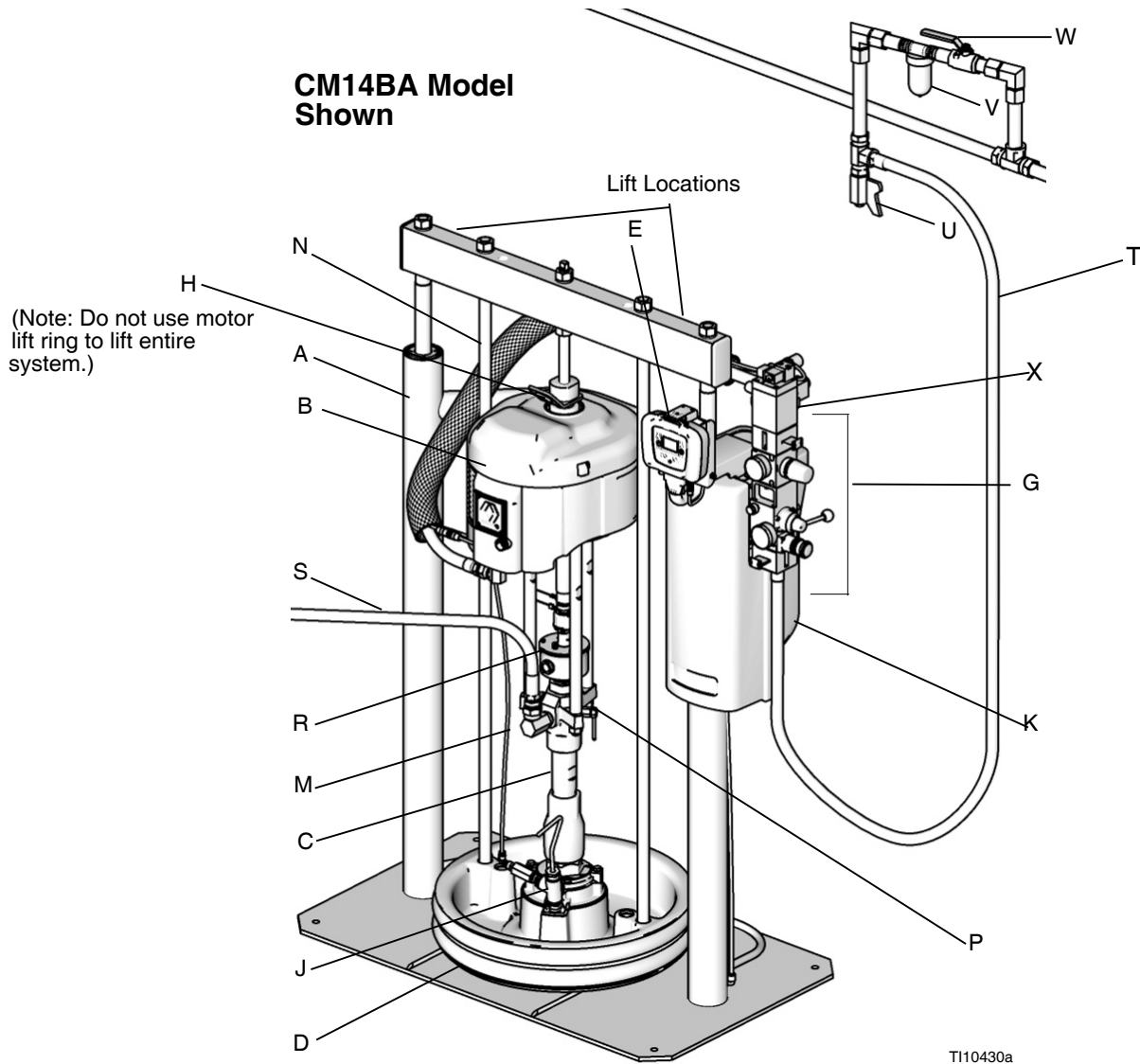
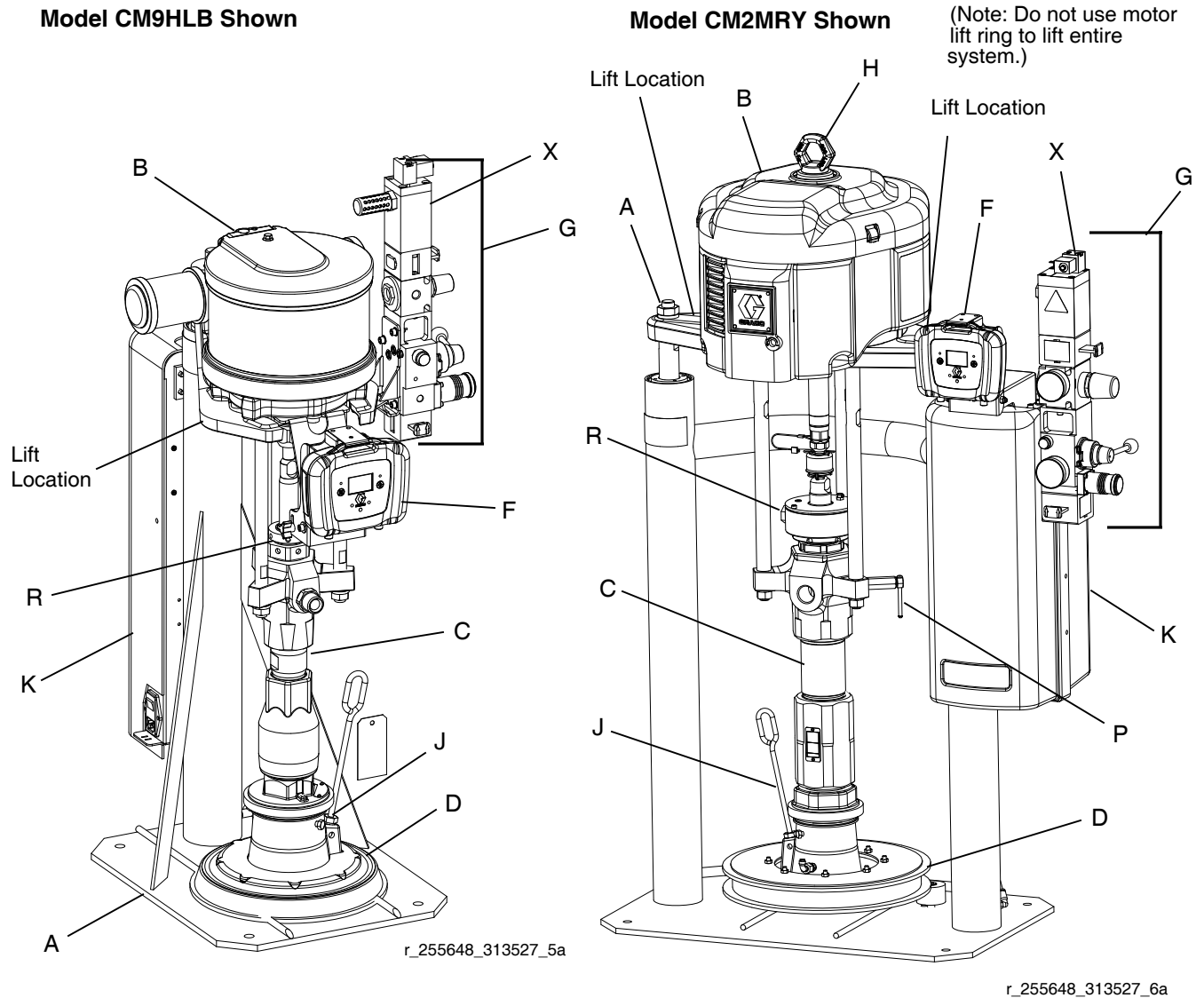


FIG. 1

**Key:**

- |   |   |   |   |
|---|---|---|---|
| A | Ram Assembly  | N | Platen Lift Rod                             |
| B | Air Motor   | P | Pump Bleed Valve                            |
| C | Displacement Pump   | R | Enclosed Wet Cup                            |
| D | Platen  | S | Fluid Line (not supplied)                   |
| F | Remote DataTrak (single ram systems) or Display Module (tandem systems) | T | Air Line (not supplied)                     |
| G | Integrated Air Controls (see FIG. 3)                                    | U | Air Line Drain Valve (not supplied)         |
| H | Air Motor Lift Ring   | V | Air Filter (not supplied)                   |
| J | Platen Bleed Port   | W | Bleed Type Air Shutoff Valve (not supplied) |
| K | Power Supply Box (under shrouding)                                      | X | Air Motor Solenoid                          |
| M | Blowoff Air Supply Line   |   |   |

## S20 3 in. Single Post and D60 3 in. Dual Post



**FIG. 2**

**Key:**

- A Ram Assembly
- B Air Motor
- C Displacement Pump
- D Platen
- F Remote DataTrak (single ram systems) or Display Module (tandem systems)
- G Integrated Air Controls (see FIG. 3)
- H Lift Ring
- J Platen Bleed Port
- K Power Supply Box (under shrouding)
- P Pump Bleed Valve
- R Enclosed Wet Cup
- S Fluid Line (not supplied, see FIG. 1)
- T Air Line (not supplied, see FIG. 1)
- U Air Line Drain Valve (not supplied, see FIG. 1)
- V Air Filter (not supplied, see FIG. 1)
- W Bleed Type Air Shutoff Valve (not supplied, see FIG. 1)
- X Air Motor Solenoid

## Integrated Air Control Module

D200, D200s, D60, and S20 Models

The integrated air controls include:

- **Main air slider valve (BA):** turns air on and off to the system. When closed, the valve relieves pressure downstream.
- **Ram air regulator (BB):** controls ram up and down pressure and blowoff pressure.
- **Ram director valve (BC):** controls ram direction.
- **Exhaust port with muffler (BD)**
- **Air motor regulator (BE):** Controls air pressure to motor.
- **Air motor slider valve (BF):** turns air on and off to the air motor. When closed, the valve relieves air trapped between it and the air motor. Push the valve in to shutoff. **Remote DataTrak:** The air solenoid, the air motor slider valve (BF), and the main air slider valve (BA) must be open for air to flow. (See **Remote DataTrak Setup**, in manual 312371)
- **Blowoff button (BG):** turns air on and off to push the platen out of an empty drum.

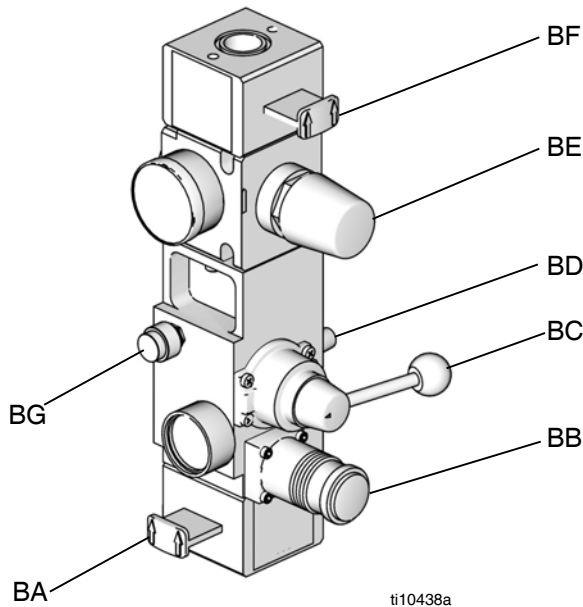


FIG. 3. Integrated Air Control Module

## Integrated Air Line Accessories

See FIG. 1.

- **Air line drain valve (U)**
- **Air line filter (V):** removes harmful dirt and moisture from compressed air supply.
- **Second bleed-type air valve (W):** isolates air line accessories for servicing. Locate upstream from all other air line accessories.
- **Air relief valve (not visible):** automatically relieves excessive pressure.

## 2-Button Interlock Air Controls

D200i, D200si, and D60i Models

Units that have 2-Button Interlock controls have the following additional components:

- **2-Button Module:** See manual 312374 for information.
- **Roller switch (CA):** shuts off air supply when it contacts the bracket actuator. Operator must push and hold buttons to resume ram movement.

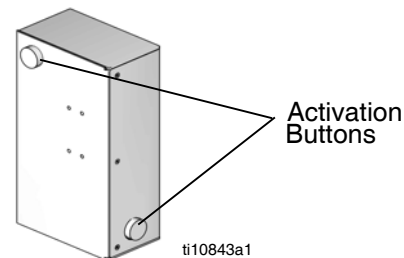


FIG. 4

- **Bracket actuator (CB):** attaches to the platen lift rod. When ram is near the top, actuator makes contact with the roller switch.

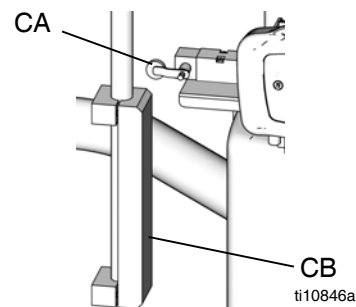
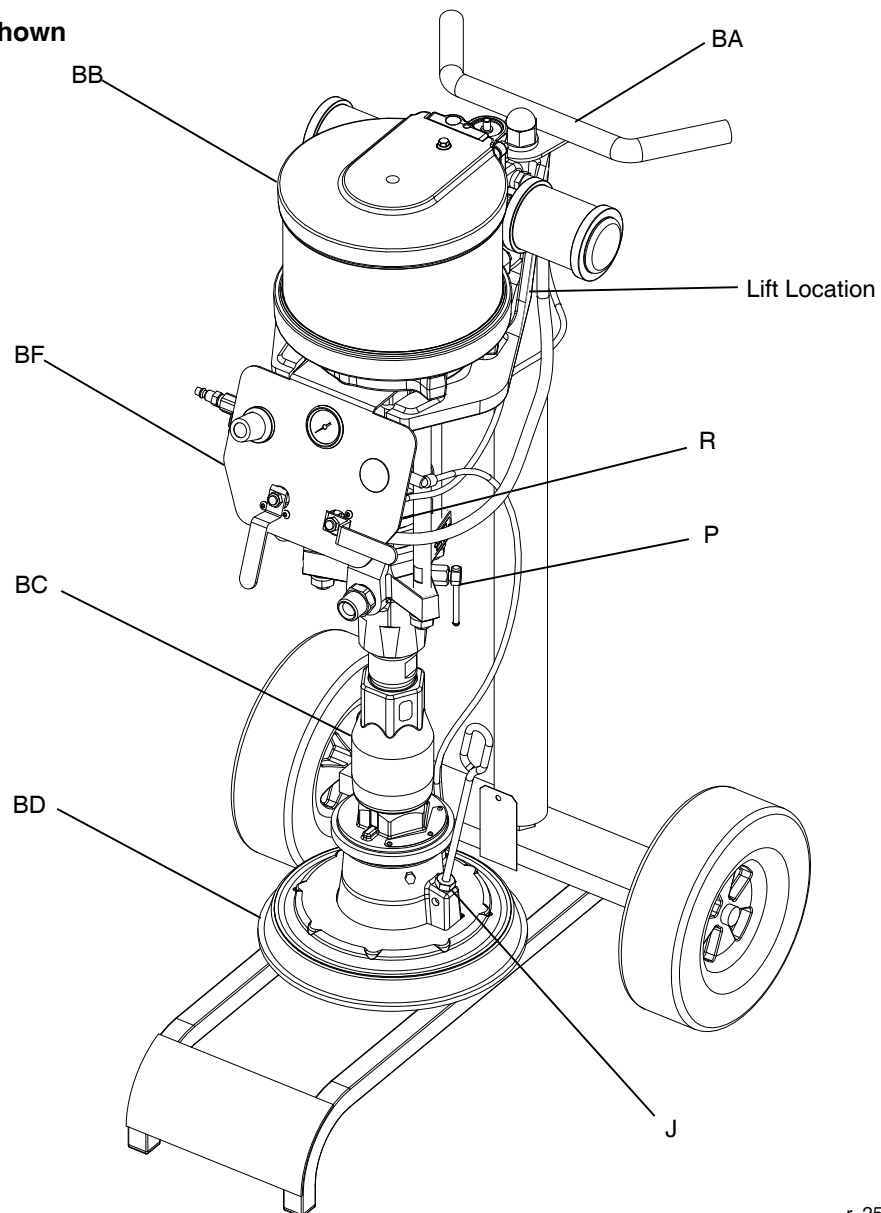


FIG. 5

## L20c 2in. Elevator

CM7B1G Model Shown



r\_257302\_312376\_1e

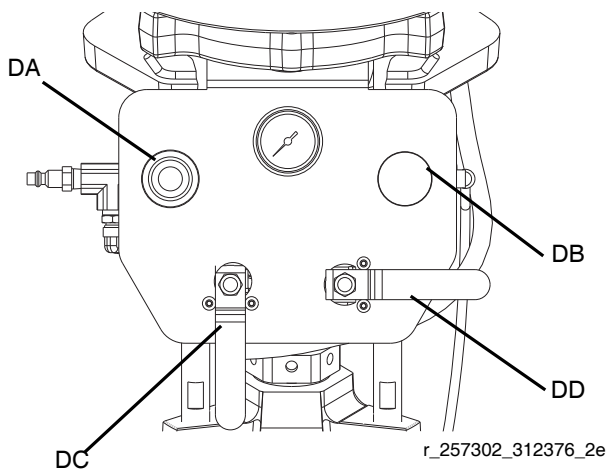
**FIG. 6**

**Key:**

- BA Elevator Cart
- BB Air Motor
- BC Displacement Pump
- BD Platen
- BF Elevator and Pump Air Controls
- J Platen Bleed Port
- P Pump Bleed Valve
- R Enclosed Wet Cup (behind air controls)

## L20c 2 in. Air Controls

- **Air motor regulator (DA):** Controls air pressure to motor.
- **Blowoff button (DB):** turns air on and off to push the platen out of an empty drum.
- **Air motor shutoff valve (DC):** turns air on and off to the air motor.
- **Elevator director valve (DD):** controls elevator direction.



**FIG. 7: Elevator Air Controls**

### Air and Fluid Hoses

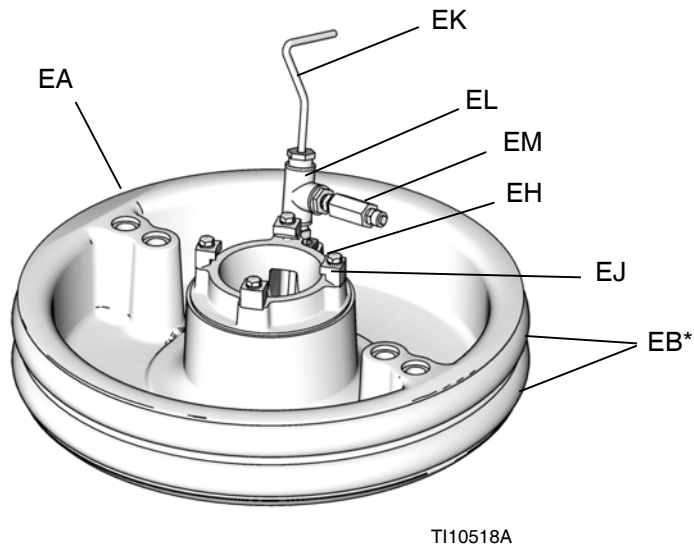
Be sure all air hoses (AI) and fluid hoses (AH) are properly sized and pressure-rated for your system. Use only electrically conductive hoses. Fluid hoses must have spring guards on both ends. Use of a short whip hose and a swivel between the main fluid hose and the gun/valve allows freer gun/valve movement.

# Platen Component Identification

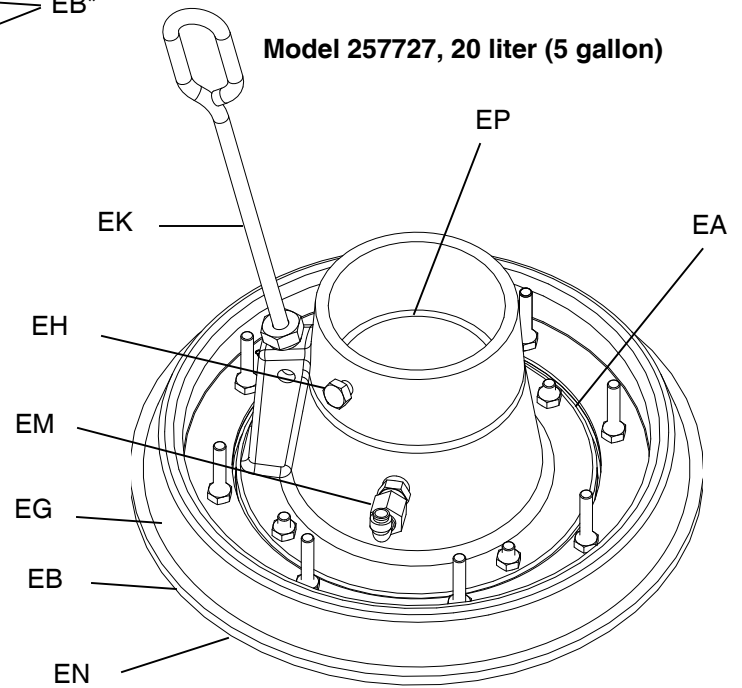
Model 255664, 200 liter (55 gallon)

Model 25N344, 200 liter (55 gallon)

Model 273233, 200 liter (55 gallon)



TI10518A



r\_255648\_313527\_7a

**FIG. 8**

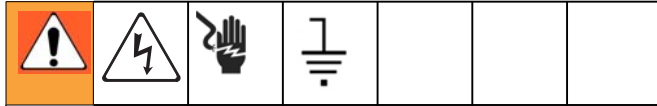
**Key:**

- EA Plate
- EB Wipers
- EG Spacer
- EH Cap Screws
- EJ Clamps
- EK Bleed Handle
- EL Bleed Valve
- EM Air Assist Body Check Valve
- EN Wiper Plate (under wiper)
- EP O-ring Seal

\* Parts not included with 25N344.

# Before Beginning Repair

## Grounding



The equipment must be grounded. Grounding reduces the risk of static and electric shock by providing an escape wire for the electrical current due to static build up or in the event of a short circuit.

**Pump:** use a ground wire and clamp. Loosen grounding lug locknut and washer. Insert one end of a 1.5 mm<sup>2</sup> (12 ga) minimum ground wire into the slot in lug and tighten the locknut securely. Connect the other end of the wire to a true earth ground.

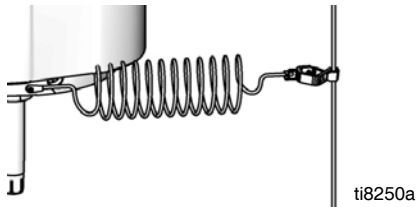


FIG. 9

**Air hoses:** use only electrically conductive hoses.

**Fluid hoses:** use only electrically conductive hoses.

**Air compressor:** follow manufacturer's recommendations.

**Spray gun/dispense valve:** ground through connection to a properly grounded fluid hose and pump.

**Fluid supply container:** follow local code.

**Object being sprayed:** follow local code.

**All solvent pails used when flushing:** follow local code. Use only conductive metal pails placed on a grounded surface. Do not place the pail on a nonconductive surface, such as paper or cardboard, which interrupts the grounding continuity.

**To maintain grounding continuity when flushing or relieving pressure,** always hold a metal part of the gun/valve firmly to the side of a grounded metal pail, then trigger the gun/valve.

## Pressure Relief Procedure



1. Lock the gun/valve trigger.
2. **For D200s, D200, S20, and D60 Air Controls:** See FIG. 3, page 12.
  - a. Close the air motor slider valve (BF) and the main air slider valve (BA).
  - b. Set the ram director valve to DOWN. The ram will slowly drop.
  - c. Jog the director valve (BC) up and down to bleed air from ram cylinders.
3. **For L20c Air Controls:** See FIG. 7, page 14.
  - a. Close the air motor valve (DC) and the elevator director valve (DD). The ram will slowly drop.
4. Unlock the gun/valve trigger.
5. Hold a metal part of the gun/valve firmly to the side of a grounded metal pail, and trigger the gun/valve to relieve pressure.
6. Lock the gun/valve trigger.
7. Open the fluid line drain valve and the pump bleeder valve (P). Have a container ready to catch the drainage.
8. Leave the pump bleeder valve (P) open until ready to spray again.




*If you suspect that the spray tip/nozzle or hose is completely clogged, or that pressure has not been fully relieved after following the steps above, very slowly loosen the tip guard retaining nut or hose end coupling and relieve pressure gradually, then loosen completely. Now clear the tip/nozzle or hose.*



## Flush Before Using Equipment

The pump was tested with lightweight oil, which is left in the fluid passages to protect parts. To avoid contaminating your fluid with oil, flush the pump with a compatible solvent before use. See your pump manual for flushing directions.

## Maintenance Procedures

						
<p>To reduce the risk of serious injury whenever you are instructed to relieve pressure, always follow the <b>Pressure Relief</b> procedure.</p>						

## Platen Maintenance

See FIG. 10. If the platen does not come out of the pail easily when the pump is being raised, the air assist tube (F), or check valve may be plugged. A plugged valve prevents air from reaching the underside of the plate to assist in raising it from the pail.

1. Relieve pressure. Refer to parts illustration on page 58 and disassemble air assist valve as shown.
2. Clear air assist tube (F) in platen. Clean all parts of valve and reassemble.
3. Remove bleed stick (EK) from platen. Push bleed stick through bleed relieve ports to remove material residue.

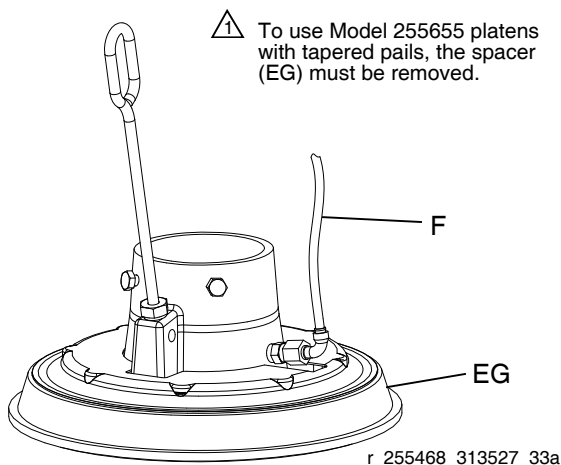


FIG. 10

## Adjust Spacers

### Use Platen with Tapered and Straight Sided Pails

The platen is supplied for use with 20 liter (5 gallon), 30 liter (8 gallon), and 60 liter (16 gallon) straight sided pails, but only single wiper platens can be easily modified for use with tapered pails.

### Use platen with tapered pails

1. Working from the bottom, use screwdriver to pry spacer (EG) loose. Work spacer upward completely above the flange of the platen. See FIG. 11.
2. By hand, angle spacer (EG) and work it off the plate, pulling it down over the flange and bottom wipers (EB). See FIG. 12.
3. Save spacer (EG), as it is required for other applications.

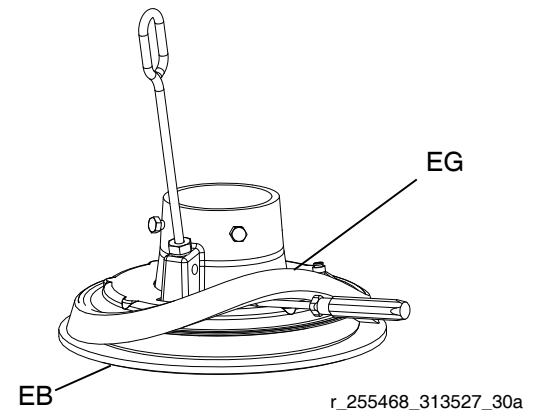
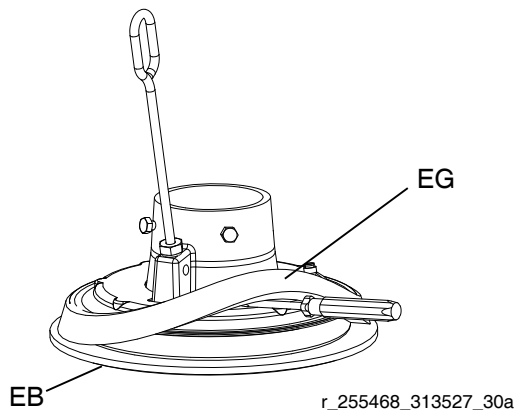


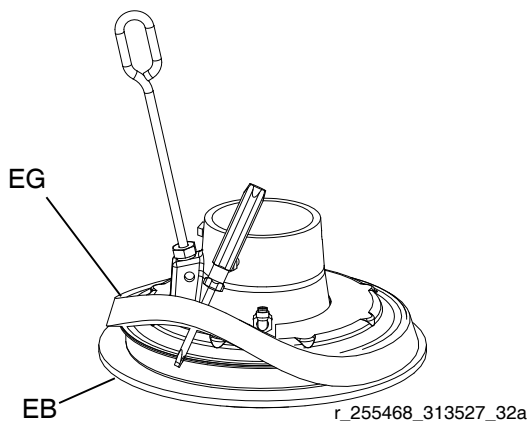
FIG. 11

### Use platen with straight sided pail

1. Ensure large diameter of spacer (EG) is facing **down**. Work spacer (EG) up over the platen by hand completely above the flange of the platen. See FIG. 12.
2. *Working from the top*, use screwdriver to position spacer (EG) between flange and wipers (EB). See FIG. 13.



**FIG. 12: Sliding spacer**



**FIG. 13: Installing Spacer**

## Remove and Reinstall Wipers

### Disassemble 20, 30, and 60 Liter Wiper Assemblies

1. Remove wiper assembly; see FIG. 14:
  - a. For all single wiper platens: Remove two clips (470) with needle nose pliers and remove platen cover (469).
  - b. Remove eight nuts (459) that hold wiper assembly to platen casting (451) and remove wiper assembly.
  - c. See **Reassemble 20, 30, and 60 Liter Wiper Assemblies** to change wiper sizes, styles, or a complete wiper assembly.
2. Remove eight nuts (459) on wiper assembly.
3. Separate top plate (457), spacer (452), wiper(s) (453), wiper support (454), and bottom plate (455).
4. Clean, inspect, and replace worn components.

## Reassemble 20, 30, and 60 Liter Wiper Assemblies

1. Assemble wiper assembly.
  - a. *For single wiper assemblies:* Place bottom plate (455) on flat surface. Place wiper support (454), wiper (453), spacer (452), and top plate (457) on bottom plate (455).
  - b. *For single wiper assemblies with SST platens:* Place bottom plate (455) on flat surface. Place wiper support (454), wiper (453), flowered wiper support (460), PTFE spacer (452), and top plate (457) on bottom plate (455).
  - c. *For double wiper assemblies:* Place bottom plate (455) on flat surface. Place wiper support (454), wiper (453), spacer (452), wiper (453) and top plate (457) on bottom plate (455).
  - d. Install eight nuts (409) on outer ring. Torque to 45 in-lbs (61 N•m).
  - e. Replace o-ring (456), or install new o-ring under platen casting (451). Use lubricant to hold in place.
  - f. Install platen casting (451). Tighten with four nuts (509).

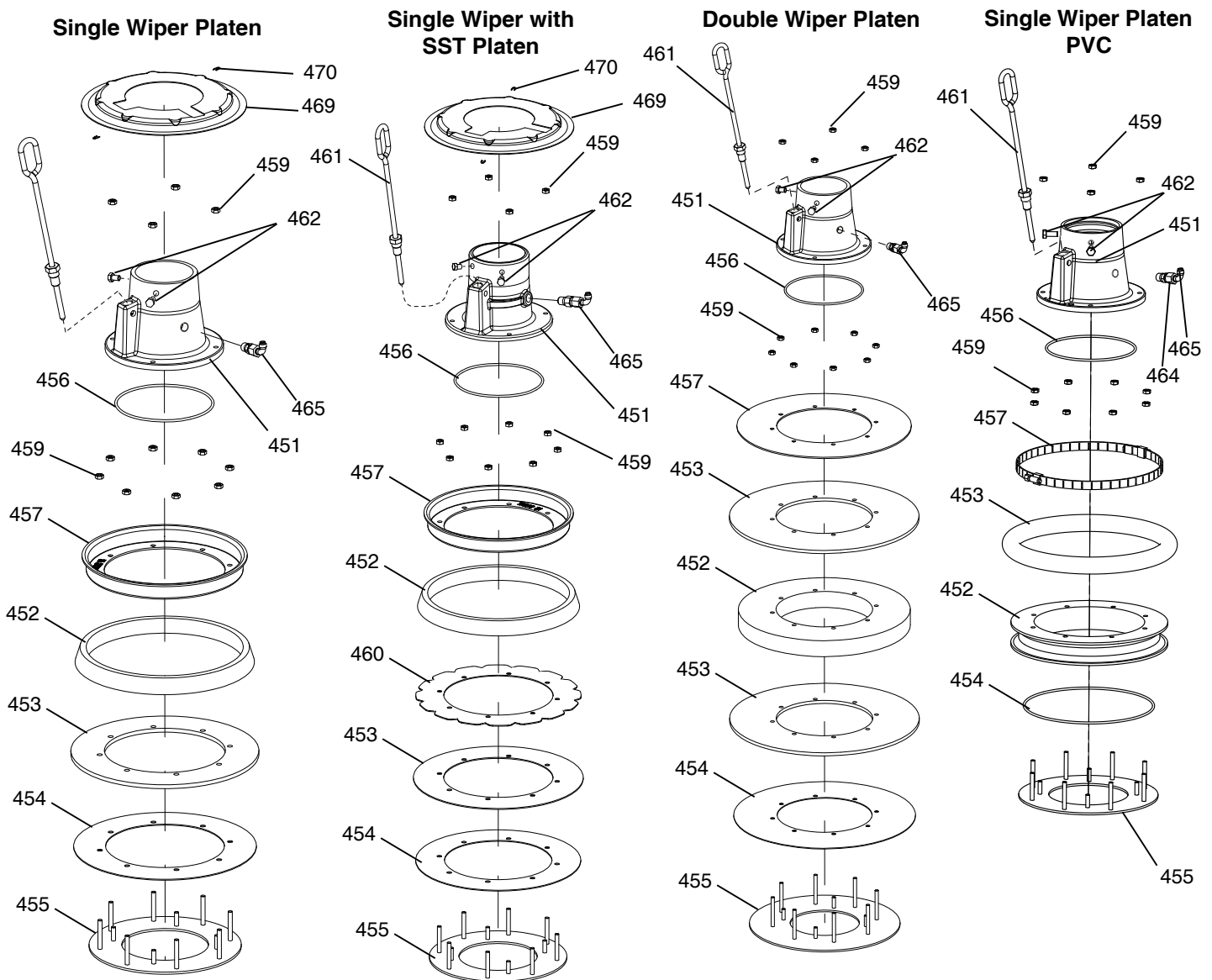


FIG. 14: Single and Double Wiper Assemblies

### Remove 30 and 55 Gallon Platen Wipers

1. To replace worn or damaged wipers (EB), raise platen up out of drum. Remove drum from base. Wipe fluid off of platen.
2. Cut top and bottom wipers with knife and remove from platen. See FIG. 15.

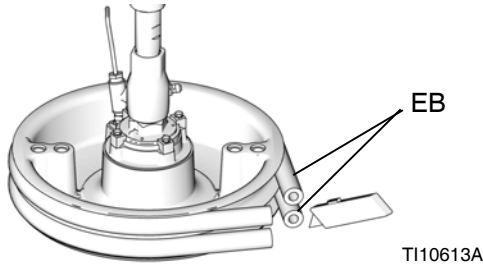


FIG. 15

### Reinstall 30 and 55 Gallon Platen Wipers

1. Using a wooden or plastic tool to prevent damage to the wiper (EB), clean all material from seal grooves.
2. Working from the bottom, angle one wiper (EB) over back of platen. See FIG. 16.
3. Insert wiper (EB) in top groove and run front of wiper into groove.
4. 55 gallon wiper only: Insert second wiper (EB) in lower groove and run front of wiper into groove.
5. Lubricate outside of wiper with lubricant compatible with material being pumped. Check with material supplier.

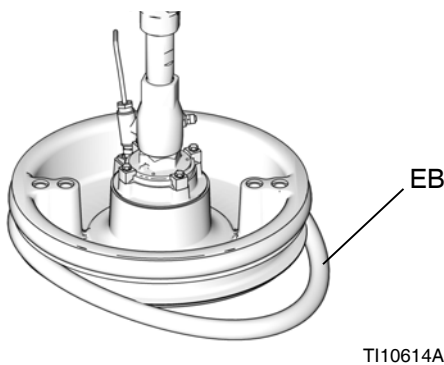


FIG. 16

### Remove 55 Gallon Platen Hose Wipers

1. To replace worn or damaged wipers (EB), raise platen up out of drum. Remove drum from base. Wipe fluid off of platen.
2. Loosen ends of banding (410) with jack screw. See FIG. 17.

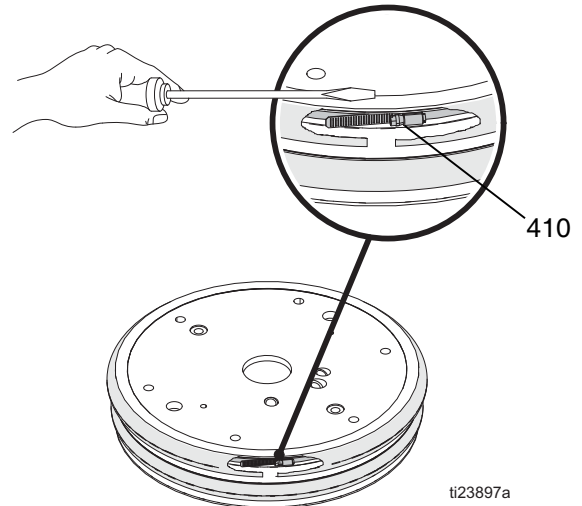
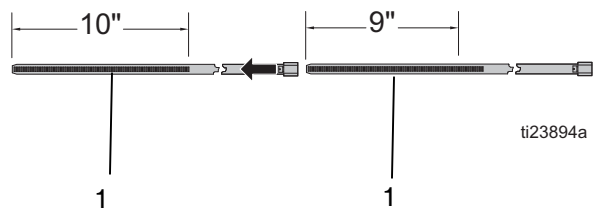


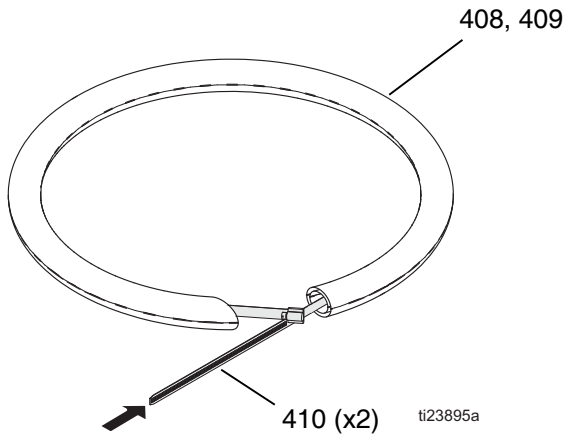
FIG. 17

### Reinstall 55 Gallon Plate Hose Wipers

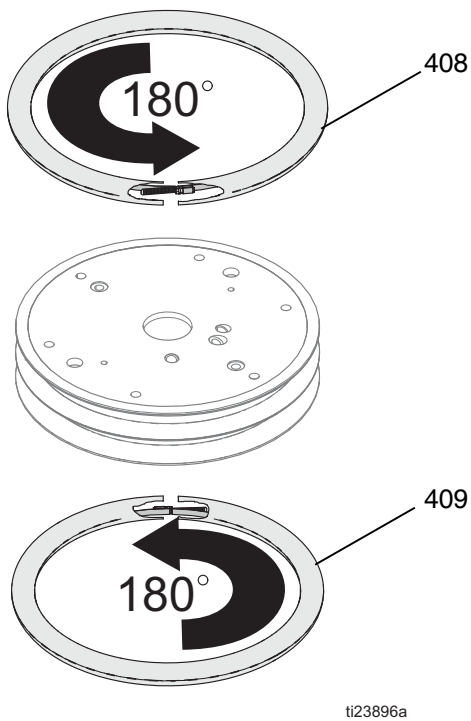
1. Clean all material from the seal grooves. Lubricate ram plate grooves before assembly.
2. Assemble two bands (410) together. Align one end of band about 9 in. from jack screw and tape attached band. Install screw jack in slot.



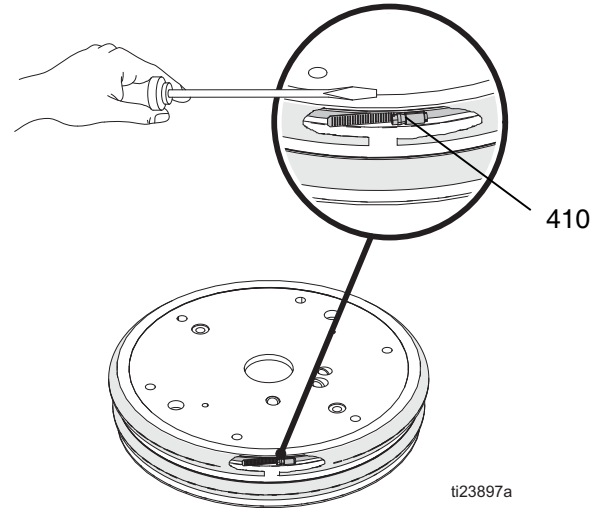
3. Insert jack screw end of band (410) into hose (408 or 409) and push completely through hose.



**NOTE:** To prevent material from potentially leaking past both hoses, ensure hose (408,409) seams are 90°-180° apart, and not on top of each other.



4. Lubricate outside of hoses (408,409) and place on upper or lower groove on plate. Adjust hose and band so that the angled ends of hose press against each other. Tighten two ends of banding (410) together with jack screw.



5. Work hose to completely close gap at the ends.

# Troubleshooting

Check all possible problems before disassembling the ram, pump, or platen. Refer to **Supply Unit Operation** manual 313526 for descriptions of DataTrak diagnostic codes. Refer to **Check-Mate Pump Packages** manual 312376 for pump troubleshooting.

## Ram

Problem	Cause	Solution
Ram will not raise or lower.	Closed air valve or clogged air line.	Open, clear.
	Not enough air pressure.	Increase.
	Worn or damaged piston.	Replace. See <b>Supply Unit Repair</b> on page 31.
	Hand valve closed or clogged.	Open, clear.
Ram raises and lowers too fast.	Air pressure is too high.	Decrease.
Air leaks around cylinder rod.	Worn rod seal.	Replace. See <b>Supply Unit Repair</b> on page 31.
Fluid squeezes past ram plate wipers.	Air pressure too high.	Decrease.
	Worn or damaged wipers.	Replace. See <b>Remove and Reinstall Wipers</b> on page 18.
Pump will not prime properly or pumps air.	Closed air valve or clogged air line.	Open, clear.
	Not enough air pressure.	Increase.
	Worn or damaged piston.	Replace. See pump manual.
	Hand valve closed or clogged.	Open, clear. See <b>Platen Maintenance</b> on page 17.
	Hand valve is dirty, worn, or damaged.	Clean, service.
Air assist valve will not hold drum down or push plate up.	Closed air valve or clogged air line.	Open, clear. See <b>Platen Maintenance</b> on page 17.
	Not enough air pressure.	Increase.
	Valve passage clogged.	Clean. See <b>Platen Maintenance</b> on page 17.

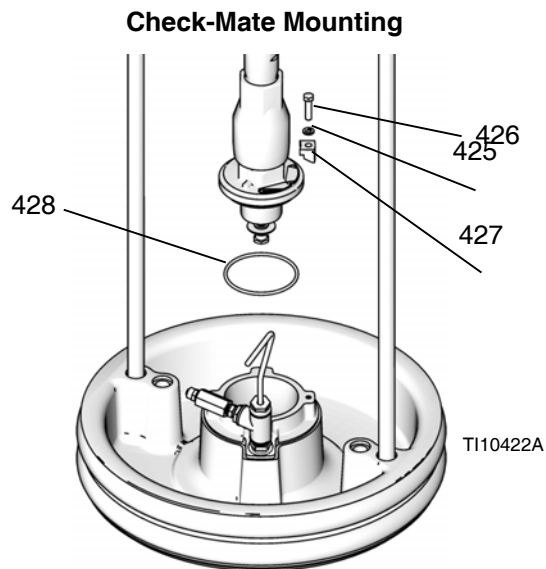
# Repair

## Disconnect Pump from Platen

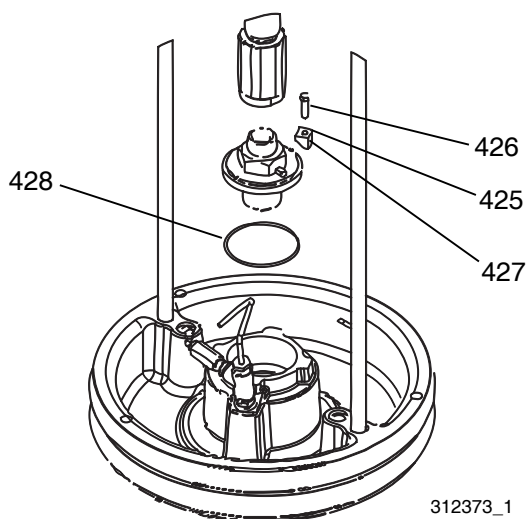
The pump is mounted to the platens by mounting kit 255392 or 257630. See the **Repair Kits** on page 64.

### 30 and 55 Gallon Platen

1. Remove four hex screws (426), four clamps (427), and washers (425).
2. Carefully pull pump away to prevent damage to pump inlet and remove o-ring (428)



### Dura-Flo Mounting

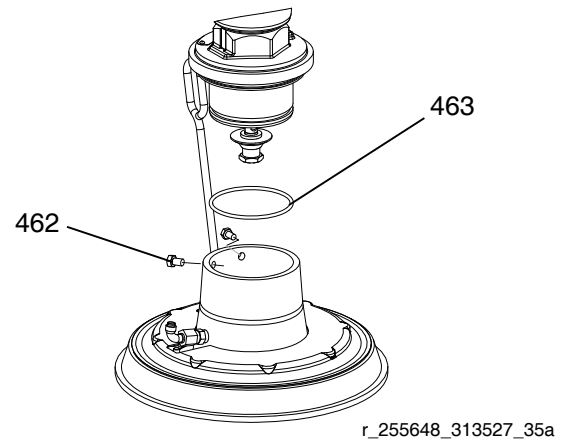


**FIG. 18: 55 and 30 Gallon Mounting Kit**

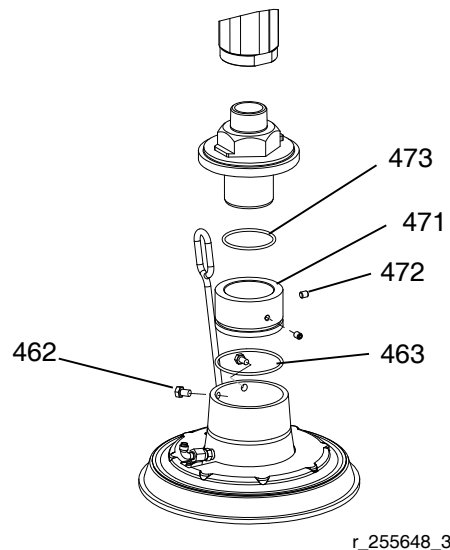
### 20, 30, and 60 Liter Platen

1. Loosen two 5/16 in. screws (462) from platen.
2. Carefully pull pump away to prevent damage to pump inlet. If using a pump with intake adapter, remove screws (472), adapter (471), and o-rings (473, 463) from pump inlet.

### Check-Mate Mounting



### Dura-Flo Mounting



**FIG. 19: 20, 30, and 60 liter mounting kit**

## Connect Platen

### 30 and 55 Gallon Platen

1. Place o-ring (428) from mounting kit 255392 on the platen. If attached to plate, place displacement pump onto platen. See FIG. 18.
2. Secure pump's intake flange to plate with screws (426), washers (425), and clamps (427) included in mounting kit 255392.

### 20, 30, and 60 Liter Platen

**NOTE:** Before installing the 20, 30, or 60 liter platen to a pump with an intake adapter, install adapter and o-ring from mounting kit 257630 using the two set screws. See FIG. 19.

1. Place o-ring (473) from mounting kit 257630 on pump intake. Loosen mounting bracket screws (401) and carefully lower pump onto o-ring (463) and platen.
2. Secure pump's intake flange to plate with screws (401).

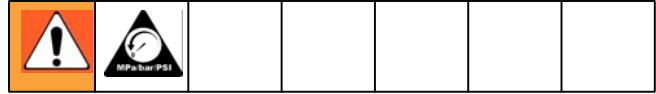
## Remove Wipers

See **Remove and Reinstall Wipers** on page 17.

## Install Wipers

See **Remove and Reinstall Wipers** on page 17.

## Remove Displacement Pump



The procedure for removing your displacement pump depends on which air motor and platen your unit uses. Find your ram unit, air motor, and platen below to remove the displacement pump. Refer to your Check-Mate Displacement Pump 312376 manual to repair the displacement pump.

If the air motor does not require servicing, leave it attached to its mounting. If the air motor does need to be removed, see page 27.

### D200 3 in. and D200s 6.5 in. Supply Units

#### NXT Air Motors:

1. See **Disconnect Displacement Pump** in Check-Mate Pump Packages manual 312376.
2. Raise the air motor:
  - a. For *NXT 2200-6500 with 55 gallon platen*: Loosen nut (105a) under ram bar and thread it down the threaded rod (106) to the lift ring adapter (107) holding the motor. Use wrench on nut (105) on top of ram bar to raise air motor.

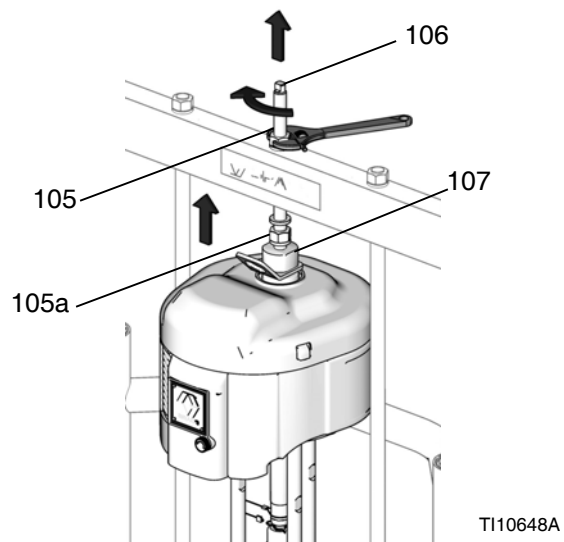


FIG. 20

T110648A



b. For NXT 200-1800 with 55 gallon platen: Go to step 3.

c. For NXT with smaller platens and all supply units: See procedure for **D60 3 in. Dual Post, S20 3 in. Single Post, and L20c 2 in. Supply Units.**

3. See **Disconnect Pump from Platen** on page 23 to disconnect the platen from the displacement pump.
4. Use two people to lift out the displacement pump.

#### Xtreme XL Air Motors:

1. Remove nuts and washers (102, 103) from top of platen lift rods (101). See FIG. 21.

#### NOTICE

Do not remove or adjust the nuts (102) below the brackets. See Fig. 21. If the nuts are adjusted the pump will not fully engage with the platen or the smaller distance will put stress on the motor, tie rods, and displacement pump.

2. See **Disconnect Displacement Pump** in Check-Mate Pump Packages manual 312376.
3. See **Disconnect Pump from Platen** on page 23 to disconnect the platen from the displacement pump.
4. Raise ram to ensure air motor assembly is clear of lower pump assembly and platen.
5. Remove displacement pump and service as needed.

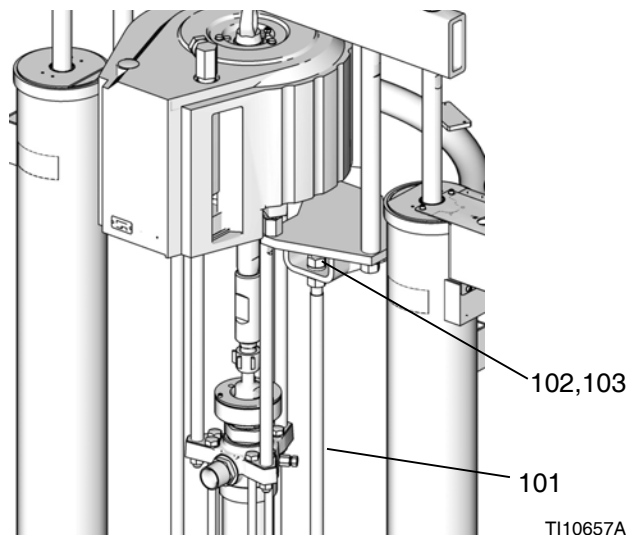


FIG. 21

## D60 3 in. Dual Post, S20 3 in. Single Post, and L20c 2 in. Supply Units

#### NXT Air Motors:

1. See **Disconnect Displacement Pump** in Check-Mate Pump Packages manual 312376.
2. See **Disconnect Pump from Platen** on page 23 to disconnect the platen from the displacement pump.
3. Raise the ram assembly to lift the air motor away from the displacement pump.
4. Remove displacement pump and service as needed.

# Install Displacement Pump

## D200 3 in. and D200s 6.5 in. Supply Units

### NXT Air Motors

1. Insert displacement pump on platen. Follow **Connect Platen** steps on page 24.
2. See **Reconnect Displacement Pump** in Check-Mate Pump Packages manual 312376.
3. Reconnect ground wire and air motor harness (units with Remote DataTrak) if they were disconnected.

4. Connect air motor:
  - a. *For NXT 2200-6500 with 55 gallon platen:* Use wrench on nut (105) on top of ram bar to lower air motor onto displacement pump. See FIG. 20 on page 24. Thread nut (105) up and tighten it under ram bar. Tighten nut (105) below the crossbar to 25 ft-lb (34 N•m) maximum.
  - b. *For NXT with smaller platen:* If the motor was removed, tighten set screws (111) and washers (110) on mounting bracket (109). See FIG. 27 on page 27.

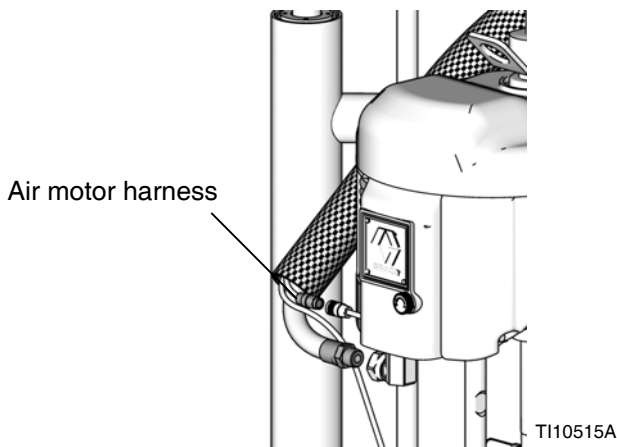


FIG. 22: NXT 2200-6500 Air Motor Harness

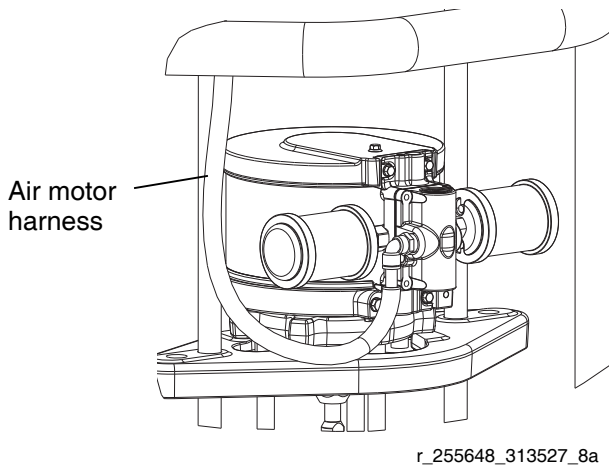


FIG. 23: NXT 200-1800 Air Motor Harness

### Xtreme XL Air Motors

1. Raise ram to install displacement pump to platen.
2. Insert displacement pump on platen. Follow **Connect Platen** steps on page 24.
3. See **Reconnect Displacement Pump** in Check-Mate Pump Packages manual 312376.
4. Tighten nuts (103) and washers (102) to top of platen lift rods (101). See FIG. 21.

**NOTICE**

Do not remove or adjust the nuts (102) below the brackets. See Fig. 21. If the nuts are adjusted the pump will not fully engage with the platen or the smaller distance will put stress on the motor, tie rods, and displacement pump.

### D60 3 in. Dual Post, S20 3 in. Single Post, and L20c 2 in. Supply Units

#### NXT Air Motors:

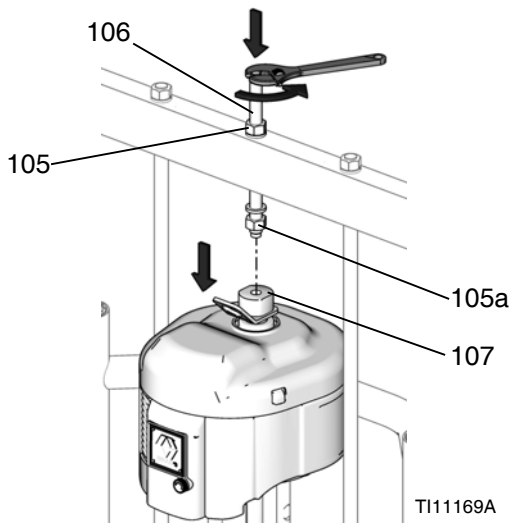
1. Raise ram to install displacement pump to platen.
2. Insert displacement pump on platen. Follow **Connect Platen** steps on page 24.
3. See **Reconnect Displacement Pump** in Check-Mate Pump Packages manual 312376.

# Remove Air Motor



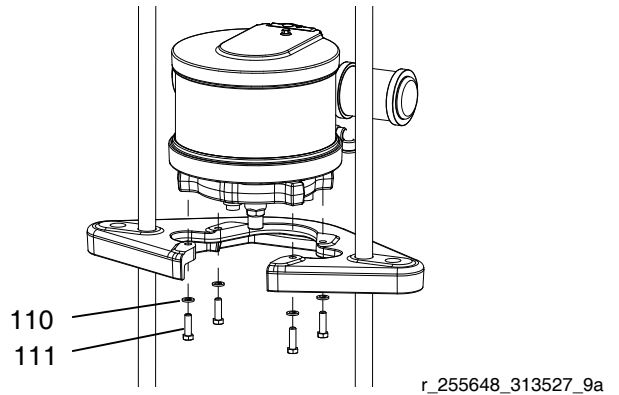
## NXT Air Motors

1. See **Disconnect Displacement Pump** in Check-Mate Pump Packages manual 312376.
2. Disconnect air hose from air motor. If using a remote DataTrak, detach electrical connections from the air motor.
3. Disconnect air motor:
  - a. For *NXT 2200-6500 with 55 gallon platen (D200 3 in. and D200s 6.5 in. supply units)*: Loosen nut (105a) below crossbar. Use wrench to hold lift ring adapter (107) in place and loosen threaded rod (106) above crossbar with another wrench. See FIG. 24.



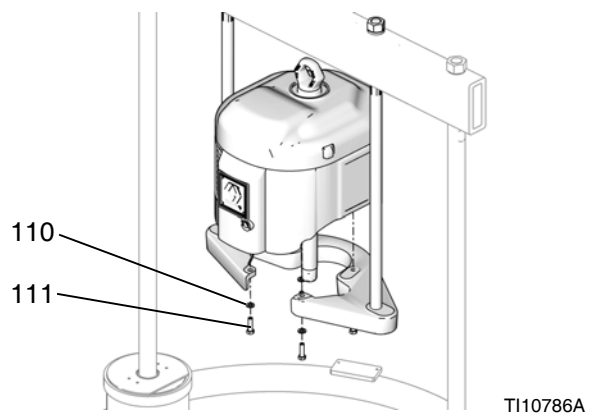
**FIG. 24: NXT 2200-6500 with 55 Gallon Platen**

- b. For *NXT 200-1800 with 55 gallon platen (D200 3 in. and D200s 6.5 in. supply units)*: Remove screws (111) and washers (110) securing motor to mounting plate. See FIG. 25.

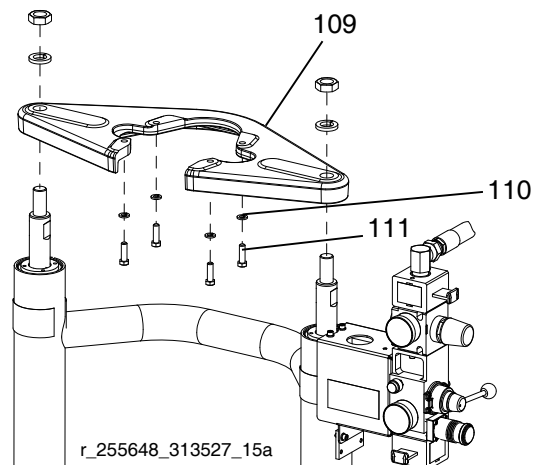


**FIG. 25: NXT 200-1800 with 55 Gallon Platen**

- c. For *NXT with smaller platen (D200 3 in., D200s 6.5 in., and D60 3 in. supply units)*: Remove screws (111) and washers (110) securing motor to mounting plate.



**FIG. 26: NXT on D200 with Small Platen**



**FIG. 27: NXT on D60 with Ram**

- d. For NXT on S20 3 in. supply unit and L20c 2 in. elevator: Remove screws (111) and washers (110) securing motor to mounting bracket.

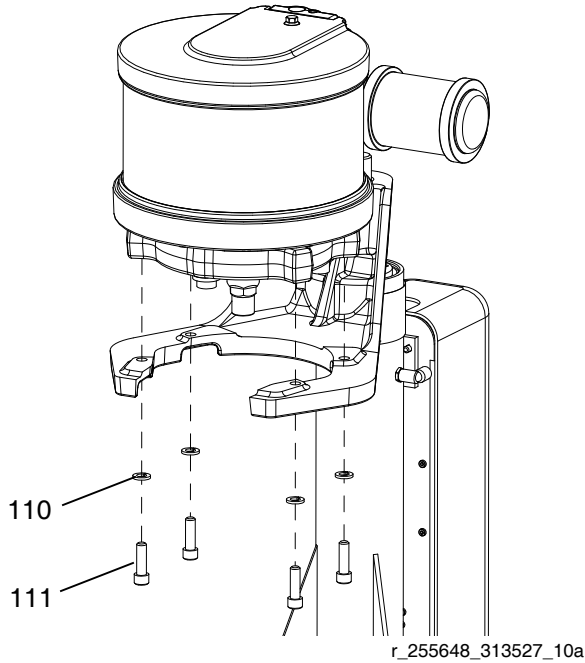


FIG. 28

4. Using a capable hoist, secure air motor to hoist and remove air motor.

### Xtreme XL Air Motors

1. Remove air hose.
2. See **Disconnect Displacement Pump** in Check-Mate Pump Packages manual 312376.
3. Remove nuts (103), washers (102), and cross bar (1c).
4. Remove nuts (114) and washers (113) under the mounting plate.
5. Using a capable hoist, secure air motor lift ring to hoist and lift air motor off of mounting plate (109).

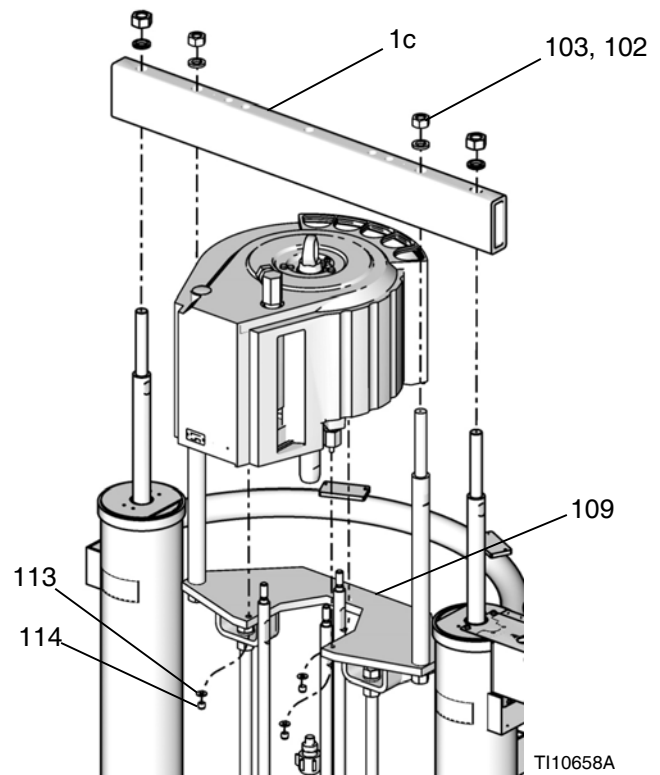


FIG. 29: Xtreme XL Air Motors

## Install Air Motor

### D200 3 in. and D200s 6.5 in. Supply Units

#### NXT with 55 gallon platen:

1. For *NXT2200-6500*: Using a capable hoist, insert tie rods into displacement pump and secure air motor to pump.
  - a. See **Reconnect Displacement Pump** in Check-Mate Pump Packages manual 312376.
  - b. Install threaded rod (106) through center hole in the crossbar. Install lock washers (104) and nuts (105) onto threaded rod (106), both above and below crossbar. Use wrench to hold lift ring adapter (107) and tighten threaded rod (106) into lift ring adapter (107) using another wrench. See FIG. 30.
  - c. Tighten nut (105) below crossbar to 25 ft-lb (34 N•m) maximum.
  - d. Tighten nut (105) above crossbar to lock motor in place.

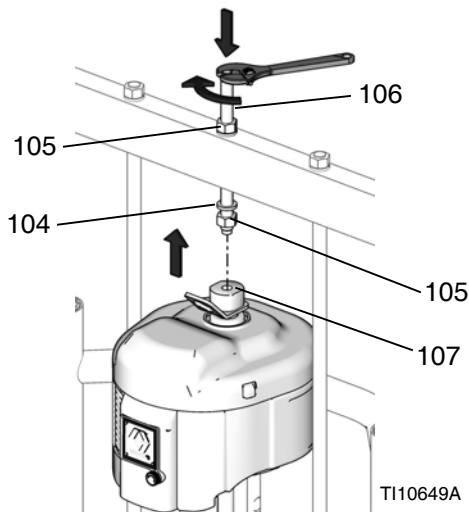


FIG. 30

2. For *NXT200-1800*: Attach motor to mounting bracket with screws (111) and washers (110). See FIG. 25 on page 27.
3. Connect air hose to motor. If using a remote DataTrak, connect electrical connections to the air motor. See FIG. 22 and FIG. 23 on page 26.

#### NXT with smaller platens:

4. Position mounting plate (109) to ensure top of motor will clear the crossbar. See FIG. 26. Using a capable hoist, attach motor to mounting plate (109) using screws (111) and washers (110).
  - a. See **Reconnect Displacement Pump** in Check-Mate Pump Packages manual 312376.
  - b. Connect air hose to motor. If using a remote DataTrak, connect electrical connections to the air motor. See FIG. 25 on page 27.

#### Xtreme XL Air Motors

1. Using a capable hoist, lower air motor on the mounting plate (109). See FIG. 29.
2. Secure motor to mounting plate (109) with nuts (114) and washers (113).
3. Install cross bar (1c), nuts (103), and washers (102).
4. See **Reconnect Displacement Pump** in Check-Mate Pump Packages manual 312376.
5. Connect air hose to motor. If using a remote DataTrak, connect electrical connections to the air motor. See FIG. 22 on page 26.

## **D60 3 in. Dual Post Supply Unit**

### **NXT Air Motors**



1. Using a secure hoist, attach motor to mounting plate (109) with screws (111) and washers (110). See FIG. 27 on page 27.
2. See **Reconnect Displacement Pump** in Check-Mate Pump Packages manual 312376.
3. Connect air hose to motor. If using a remote DataTrak, connect electrical connections to the air motor. See FIG. 25 on page 27.

## **S20 3 in. Single Post Supply Unit and L20c 2 in. Elevator**

### **NXT Air Motors**

1. Attach motor to mounting bracket with screws (111) and washers (110). See FIG. 28.
2. See **Reconnect Displacement Pump** in Check-Mate Pump Packages manual 312376.
3. Connect air hose to motor. If using a remote DataTrak, connect electrical connections to the air motor. See FIG. 25 on page 27.

## Supply Unit Repair

						
---	---	--	--	--	--	--

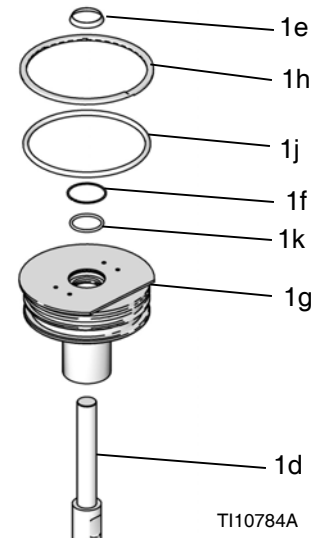
To reduce the risk of serious injury whenever you are instructed to relieve pressure always follow the **Pressure Relief Procedure** on page 16. Do not use pressurized air to remove the guide sleeve or the piston.

### D200s 6.5 in. Ram Piston Rods

Always service both cylinders at the same time. When you service the lift rod always install new o-rings in the piston rod seal and ram piston.

#### Disassemble Piston Rod Seal

1. Relieve pressure.
2. Remove the nuts (1a) and lockwashers (1b) holding the tie bar (1c) to the piston rods (1d). See parts illustration on page 39.
3. Remove nuts (103, 105) and washers (102, 104). See parts illustration on page 43.
4. Lift tie bar (1c) off of rods.
5. Remove retaining ring (1h) by gripping the ring tab with a pair of pliers and rotating the ring out of its groove.
6. Remove snap ring (1e) and rod wiper (1f).
7. Remove guide sleeve (1g) by sliding it off of rod (1d). Four 1/4 in -20 holes are provided to ease removal of the guide sleeve.
8. Inspect parts for wear or damage.



**FIG. 31: 6.5 in. Piston Rod Seal**

#### Assemble Piston Rod Seal

1. Install new o-rings (1j,1k), rod wiper (1f), and snap ring (1e). Lubricate packings with o-ring lubricant.
2. Slide guide sleeve (1g) onto rod (1d) and push it into cylinder. Replace retaining ring (1h) by feeding it around the guide sleeve groove.
3. Reinstall tie bar (1c) using nuts (1a) and lockwashers (1b). Torque to 40 ft-lb (54 N•m).
4. Reinstall washers (102, 104) and nuts (103, 105).

### Disassemble Ram Piston

1. Relieve pressure.
2. Remove nuts (1a) and lockwashers (1b) holding the tie bar (1c) to the piston rods (1d). See page 39.
3. Remove nuts (103, 105) and washers (102, 104). See parts illustration on page 43.
4. Lift tie bar (1c) off rods.
5. Remove retaining ring (1h) by gripping the ring tab with a pair of pliers and rotating the ring out of its groove.
6. Remove guide sleeve (1g) and slide it off piston rod (1d).

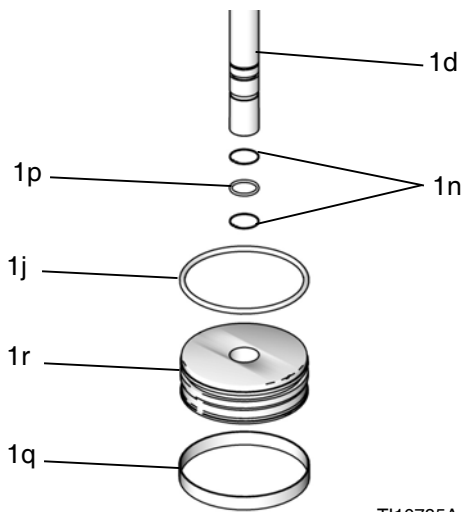
### Assemble Ram Piston

1. Install new o-rings (1p, 1j) on piston rod (1d) and piston (1r). Lubricate the piston (1r) and o-rings (1p, 1j). Reinstall piston (1r) and lower retaining ring (1n) onto piston rod (1d). Install piston guide band (1q) onto piston (1r).
2. Carefully insert piston (1r) into cylinder and push rod (1d) straight down into cylinder. Add three ounces of lubricant to each cylinder after inserting the piston (1r).
3. Slide guide sleeve (1g) onto piston rod (1d).
4. Install retaining ring (1e) and tie bar (1c) as explained in **Disassemble Ram Piston**.

#### NOTICE

**Do not** tilt the piston rod to one side when removing it from the base or when installing it. Such movement can damage the piston or inside surface of the base cylinder.

7. Carefully lay piston (1r) and rod (1d) down so rod will not be bent. Remove bottom retaining ring (1n) and o-ring (1p). Remove piston guide band (1q). Slide piston (1r) off piston rod (1d).



T110785A

**FIG. 32: 6.5 in. Ram Piston**



## D200, D60, and S20 3 in. Ram Piston Rods

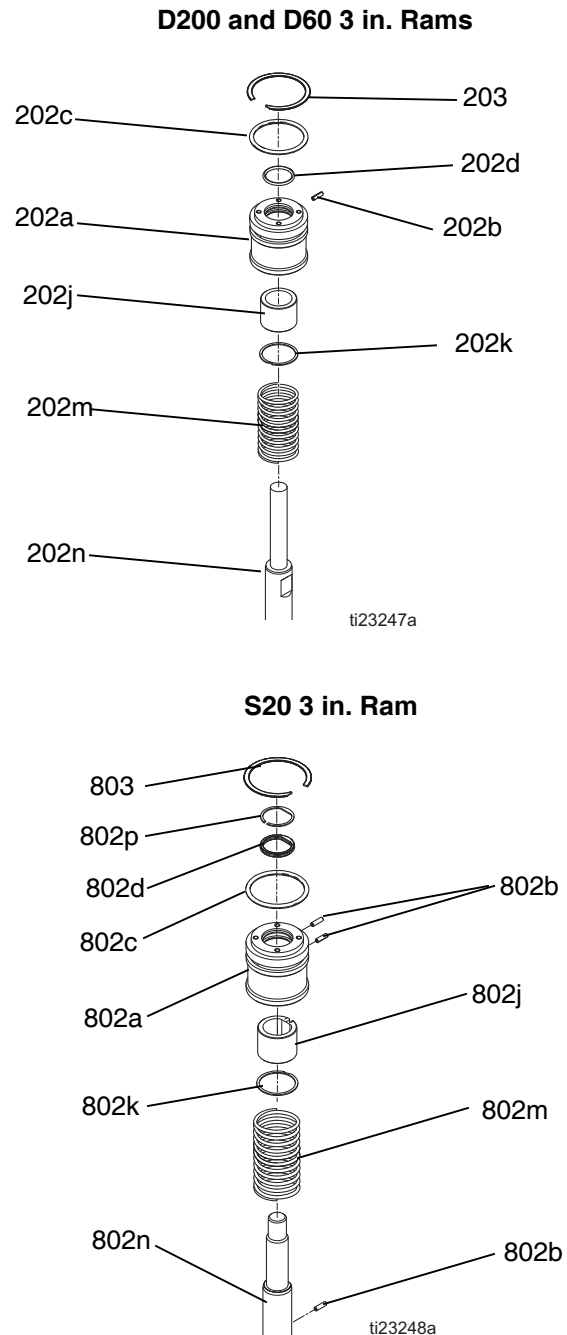
Always service both cylinders at the same time. When you service the piston rod always install new o-rings in the piston rod seal and ram piston.

### Disassemble Piston Rod Seal and Bearing

1. Relieve pressure.
2. Access piston rod seal and bearing.
  - a. *For D200 3 in. Ram:* Remove nuts (206) and lockwashers (205) holding the tie bar (204) to the piston rods (202n). Refer to parts illustration on page 41. Remove nuts (105) and washers (104). Remove tie bar (204). See page 41.
  - b. *For D60 3 in. Ram:* Ensure ram is in lowest position. Remove nuts (383) and lockwashers (382) from piston rods (302n). Remove entire pump package, including the mounting plate (381) off of the piston rods (302n). Secure pump package so pump and platen will not fall. See pages 46 and 48.
  - c. *For S20 3 in. Ram:* Ensure ram is in lowest position. Remove nut (857) and lockwasher (858) from piston rod (802n). Remove entire pump package, including the mounting plate (851) off of the piston rod (802n). Secure pump package so pump and platen will not fall. See page 51.
3. Remove retaining ring (203, 803).
4. Remove piston rod seal and bearing.
  - a. *For D200 and D60 3 in. Rams:* Slide end cap (202a), pin (202b), o-ring (202c), and spring (202m) up off of the piston rod (202n). Remove retaining ring (202k) and bearing (202j) from end cap (202a) and remove o-ring (202d).
  - b. *For S20 3 in. Ram:* **Disassemble Ram Piston** to remove end cap (802a). See page 32. Slide end cap (802a) off of the piston rod (802n). Remove retaining ring (802k) and bearing (802j) from end cap (802a). Remove seal (802d) and spacer (802p) from bearing.

5. Inspect parts for wear or damage. Replace as necessary.

**NOTE:** Do not reinstall end cap assembly if the ram piston (202e, 802e) needs to be removed from the piston rod. See the next page for ram piston repair instructions.



**FIG. 33: 3 in. Piston Rod Seal**

### Assemble Piston Rod Seal and Bearing

See FIG. 33 on page 33.

1. *For S20 3 in. Ram:* Lubricate seal (802d) and spacer (802p) and install in bearing (802j).
  - a. Align groove on bearing with pin (802b) and install bearing (802j) into end cap (802a). Lubricate o-ring (802c) and end cap (802a).
  - b. Slide spring (802m) and end cap (802a) on bottom of piston rod.
2. *For D200 and D60 3 in. Rams:* Lubricate o-ring (202d) and bottom bearing (202j).
  - a. Install o-ring (202d), bottom bearing (202j), and retaining ring (202k) into end cap (202a).
  - b. Install new o-ring (202c) and pin (202b) on end cap (202a). Lubricate o-ring (202c) and end cap (202a).
  - c. Slide spring (202m) and end cap (202a) on piston rod (202n, 302n).
3. Install retaining ring (203).
4. *For D200 3 in Ram:* Install tie bar (204), washers (204, 205), and nuts (205, 206).
5. *For D60 3 in. Ram:* Remount mounting plate (381) and attach nuts (383) and lockwashers (382). Torque to 40 ft-lb (54 N•m).
6. *For S20 3 in. Ram:* Remount mounting plate (851) and attach nut (857) and lockwasher (858). Torque to 40 ft-lb (54 N•m).

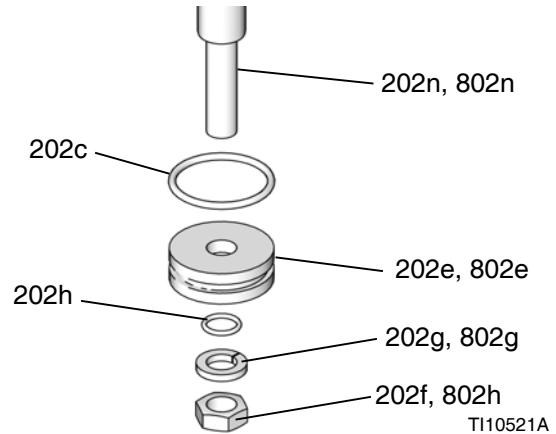
### Disassemble Ram Piston

1. Complete steps 1-4 from **Disassemble Piston Rod Seal and Bearing** to remove the end cap from the piston rod.

**NOTICE**

**Do not** tilt the piston rod to one side when removing it from the base or when installing it. Such movement can damage the piston or inside surface of the base cylinder.

2. Carefully lay piston (202e, 802e) and rod (202n, 302n, 802n) down so piston rod will not be bent. Remove nut (202f, 802f), washer (202g, 802g), piston (202e, 802e), outer o-ring (202c, 802c), and inner o-ring (202h, 802h).
3. Inspect parts for wear or damage. Replace as necessary.



**FIG. 34: 3 in. Ram Piston**

### Assemble Ram Piston

1. Install new o-rings (202h, 802h, 202c, 802c) and lubricate piston (202e, 802e) and o-rings.
2. Apply medium strength thread sealant. Install piston (202e, 802e), washer (202g, 802g), and nut (202f, 802f) on piston rod (202n, 302n, 802n).
3. Carefully insert piston (202e, 802e) into cylinder and push piston rod (202n, 302n, 802n) straight down into cylinder.
4. Slide spring (202m, 802m) and end cap (202a, 802a) onto piston rod (202n, 302n, 802n).
5. *For D200 3 in. Rams:* Install retaining ring (203), tie bar (204), washers (204, 205), and nuts (205, 206).
6. *For D60 and S20 3 in. Rams:* Install retaining ring (203) and install mounting plate with nuts (383, 857) and washers (382, 858) with pump package and platen.

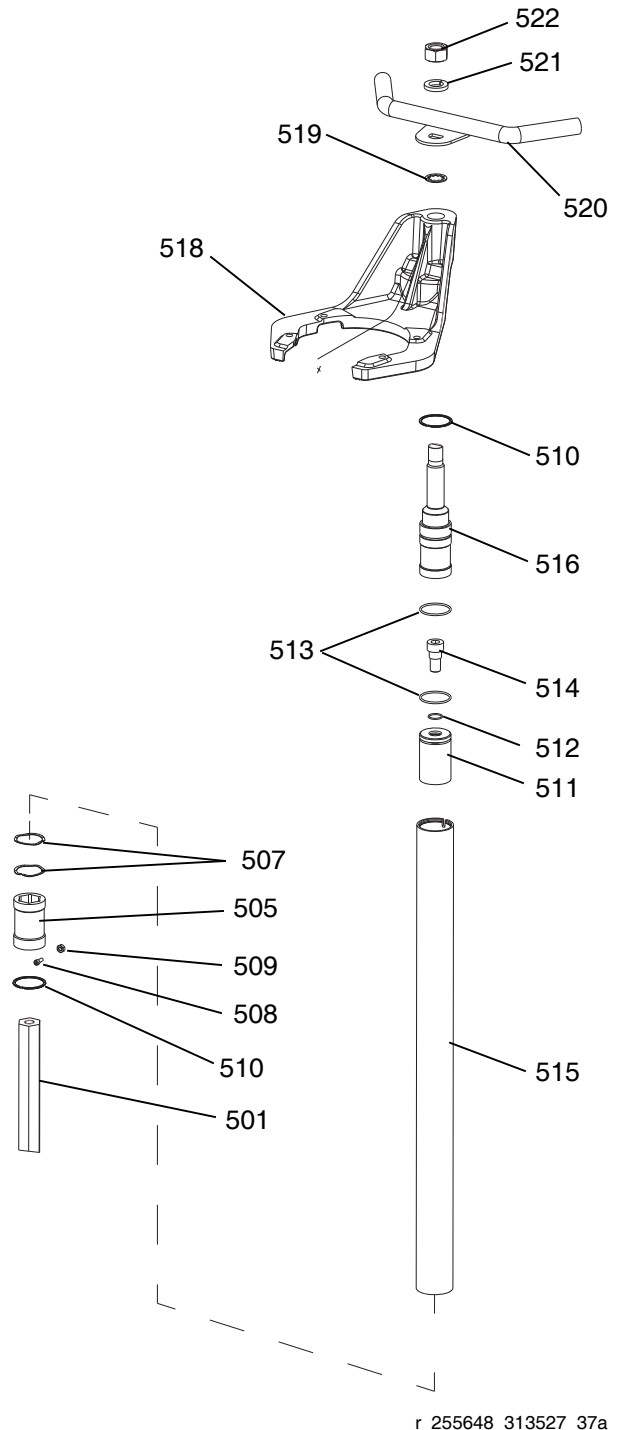
## L20c 2 in. Elevator

### Disassemble Piston Rod Seal, Bearing, and Piston

1. Remove air motor. See **Remove Air Motor** on page 27.
2. Remove nut (522), lock washer (521), handle (520), washer (519), and air motor mounting bracket (518) from end cap (516).
3. Remove retaining ring (510).
4. Remove cylinder end cap (516). Remove o-ring (513) and replace if necessary.
5. Remove screw (514) from inside cylinder (515) and lift cylinder assembly off of elevator cart (501).
6. Remove piston (511) from cylinder (515). Remove o-rings (512, 513) and inspect for damage. Replace as necessary.
7. Remove retaining ring (510) from bottom of cylinder (515).
8. Remove nut (509), screw (508), and bearing (505) from cylinder (515). Inspect bearing for damage. Replace as necessary.

### Assemble Piston Rod Seal, Bearing, and Piston

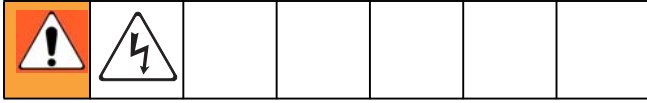
1. Install screw (508) in bearing (505). Install bearing in cylinder (515) and tighten with nut (522).
2. Install retaining ring (510) in bottom of cylinder (515) and wave spring (507) on top of bearing (505).
3. Ensure screw (508) faces backwards and install cylinder with bearing on elevator cart (501).
4. Install piston (511) with new o-rings (513) and press on to rod.
5. Install screw (514) into cart rod.
6. Install new o-ring (513) on cylinder end cap (516) and install in cylinder (515).
7. Use screwdriver to install retaining ring (510) in top of cylinder (515).
8. Install air motor mount (518) on cylinder end cap (516).
9. Install washer (519), handle (520), lock washer (521), and nut (522).



r\_255648\_313527\_37a

**Fig. 35: L20c Piston Rod Seal, Bearing, and Piston**

## Power Supply



### Remove 24 VDC Module

1. Turn external 24 VDC power source off.
2. Remove shrouding covers. See DataTrak Kit parts illustration on page 62.
3. Remove two screws (156), two washers (164), and press cover plate (160) up from the bottom. Then slide to front of ram to remove.

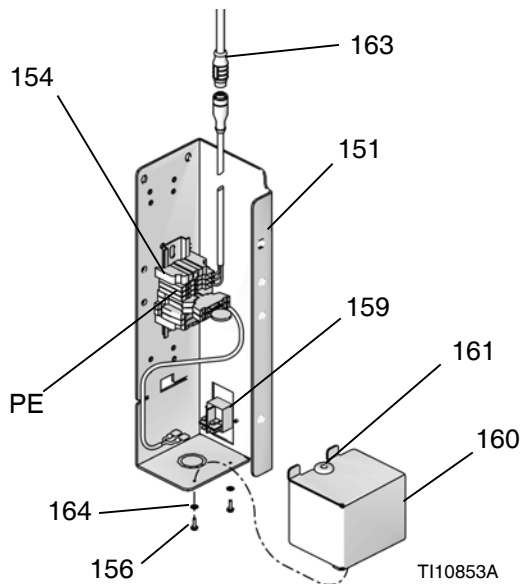


FIG. 36

4. Disconnect power supply output cable from CAN cable (163).
5. Remove quick disconnects from rocker switch terminals 1 and 4.

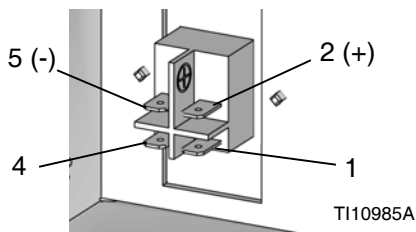


FIG. 37

6. Remove protective earthing conductor from the PE terminal marked  $\perp$ .
7. Remove screws (159) and 24 VDC power supply module (154) from power supply mounting bracket (151). See parts illustration on page 54.
8. Remove screws (155) and power switch (157) from power supply mounting bracket (151).
9. Clean and inspect all parts for wear or damage. Replace as needed.

### Replace 24 VDC Fuses

1. Complete steps 1 and 2 from **Remove 24 VDC Module**.
2. Open the fuse holder and remove two fuses. Install new fuses (165).

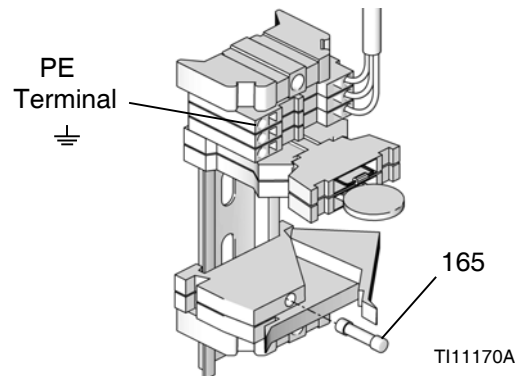


FIG. 38

### Install 24 VDC Module

1. Ensure that the external 24 VDC power source is off.
2. Mount 24 VDC module (154) on mounting bracket (151).
3. Mount power switch (159) on mounting bracket (151).
4. Attach quick disconnects on cable from 24 VDC module (154) to terminals on power switch (157).
  - a. The black wire connects to terminal 4, adjacent to terminal marked (-).
  - b. The red wire connects to terminal 1, adjacent to terminal marked (+).
5. Install power supply output cable to CAN cable (163).

6. Attach 24 V Class 2 power supply to terminals on the power switch: +24 VDC to terminal 2 (+) and 24 VDC return to terminal 5 (-). See FIG. 37. Attach protective earthing (PE) conductor to terminal marked  $\perp$ . See FIG. 38. The 24 VDC power supply must be capable of supplying at least 1.0 Amp and have supply current protection rated at no more than 2.5 Amps.
7. Install cover plate (160), screws (156), and washers (164).
8. Install shrouding covers. See DataTrak Kit parts illustration on page 62.

### Remove 100-240 VAC Power Supply

1. Turn power supply OFF and **Disconnect power**.
2. Remove shrouding covers (506, 507). See DataTrak Kit parts illustration on page 62.
3. Remove two screws (156), two washers (164), and press cover plate (160) up from the bottom. Then slide to front of ram to remove.

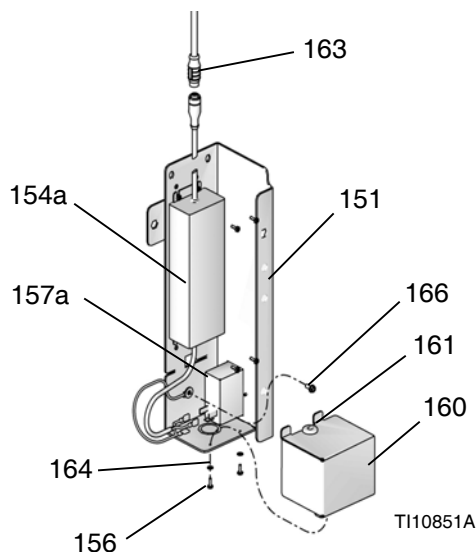


FIG. 39

4. Disconnect power supply output cable.
5. Remove quick disconnects from rocker switch.
6. Remove ground screw (166).
7. Remove screws (156) and 100-240 VAC power supply (154a) from power supply mounting bracket (151).

8. Inspect all parts for wear or damage. Replace as needed.

### Replace 100-240 VAC Fuses

1. Turn power supply OFF and **Disconnect power**.
2. Use screwdriver to remove two fuses (165) from module and install new fuses.

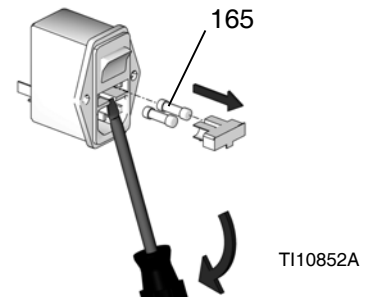


FIG. 40

### Install 100-240 VAC Power Supply

1. Turn power supply OFF and **Disconnect power**.
2. Mount power entry module (157a) and 100-240 VAC power supply (154a) on mounting bracket (151).
3. Install power supply output cable to CAN cable (509). See FIG. 39.
4. Connect power supply input quick disconnects to power switch terminals (157a).
  - a. Connect green wire to Ground  $\perp$ .
  - b. Connect brown wire to Line (L).
  - c. Connect blue wire to Neutral (N).
5. Install grounding screw (166) through eyelet terminal of power supply ground (green) pigtail wire and fasten to power supply enclosure (151).
6. Install cover plate (160), screws (156), and washers (164).
7. Install shrouding covers. See DataTrak Kit parts illustration on page 62.

# Parts

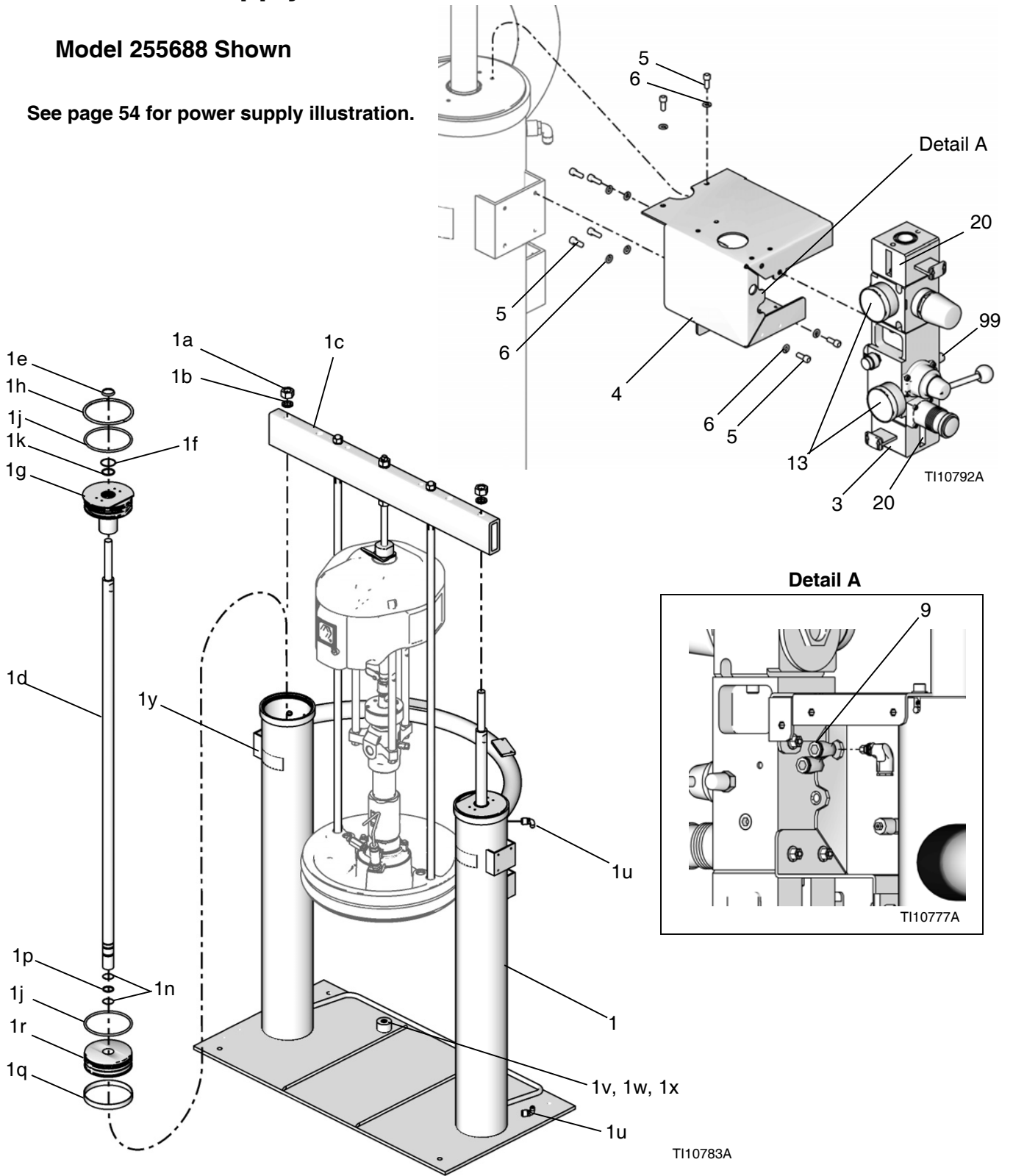
Use this table to identify which pump mounting kit and platen are compatible with each air motor and supply system. See page 40 for relief valve for your pump package.

Supply System	Pump Mounting Kit		Platens	Pump Mounting Kit Page	Platens Page
	Air Motor Size	Kit	Gallons (liters)		
<b>D200 3 in. Dual Post</b> (see page 41)	NXT200 NXT400	257627	55 (200)	pg. 43	pg. 56
		257628	5 (20), 8 (30), 16 (60)	pg. 45	pg. 58
	30 (115)		pg. 56		
	NXT700 NXT1200 NXT1800	257625	55 (200)	pg. 43	pg. 56
		257626	5 (20), 8 (30), 16 (60)	pg. 45	pg. 58
	30 (115)		pg. 56		
	NXT3400 NXT6500	255308	5 (20), 8 (30), 16 (60)	pg. 44	pg. 58
NXT2200	255309	30 (115)	pg. 56		
NXT2200 NXT3400 NXT6500	255305	55 (200)	pg. 43	pg. 56	
<b>Dura-Flo D200 3 in. Dual Post</b> (see page 41)	NXT2200 NXT3400 NXT6500	256235	55 (200)	pg. 43	pg. 56
<b>D200s 6.5 in. Dual Post</b> (see page 39)	NXT2200 NXT3400 NXT6500	255315	55 (200)	pg. 43	pg. 56
	NXT2200	255317	30 (115)	pg. 44	pg. 56
	NXT3400 NXT6500	255316		pg. 44	
	Xtreme XL	255306	55 gallon	pg. 45	pg. 57
<b>D60 3 in. Dual Post</b> (see page 46)	NXT2200	257623	5 (20), 8 (30), 16 (60)	pg. 48	pg. 58
	NXT3400 NXT6500	257624			pg. 58
<b>S20 3 in. Single Post</b> (see page 49)	NXT2200 NXT 3400	257666	5 (20)	pg. 51	pg. 58
	NXT700 NXT1200 NXT1800	257664			
	NXT200 NXT400	257664			
<b>L20c 2in. Single Post</b>	NXT200 NXT400	257613	5 (20)	pg. 53	pg. 58
	NXT700 NXT1200 NXT1800	257613			

# D200s 6.5 in. Supply Units

Model 255688 Shown

See page 54 for power supply illustration.



**D200s 6.5 in. Supply Units, 255688**

Ref.	Part	Description	Qty.
1		RAM, 6.5 in. (includes 1a - 1z)	1
1a	113939	NUT, jam, hex	2
1b	113993	WASHER, lock, helical	2
1c	15M538	BEAM, tie	1
1d	C32401	ROD	2
1e*	C03043	RING, snap	2
1f*	C31001	WIPER, rod	2
1g	617414	SLEEVE, guide, 6-1/2 in. ram	2
1h*	C32409	RING, retaining	2
1j*	C38132	O-RING	4
1k*	156593	O-RING	2
1n*	C20417	RING, retaining	4
1p*	158776	O-RING	2
1q*	C32408	BAND, guide	2
1r	C32405	PISTON, elevator air	2
1s*	100040	PLUG, pipe	2
1u	114153	ELBOW, male, swivel	2
1v	C32467	STOP, drum	2
1w	C19853	SCREW, socket hd cap	2
1x	C38185	WASHER, lock	2
1y▲	15J074	LABEL, safety	4
1z*	C14023	LABEL, ram, up-down	1
2*	C12509	TUBE, nylon, 14.6 ft (4.45 m)	1

Ref.	Part	Description	Qty.
3	255650	CONTROL, air; see 312374	1
4		BRACKET, mounting, air control	1
5	101682	SCREW, cap, sch	8
6	100016	WASHER, lock	8
9	132848	ELBOW, plug in	3
13	101689	GAUGE, pressure, air	2
20▲	15V954	LABEL, valve shut-off aircontrol	1
27*		HOLDER, cable tie, rotating	1
99		VALVE, safety relief	1

▲ Replacement Danger and Warning labels, tags, and cards are available at no cost.

\* Parts included in Supply Units Repair Kit 918432 (purchase separately).

See **Power Supply - D200s, D200, D60, and S20 3 in. Supply Unit** on page 54 for 24 VDC and 100-240 VAC power supply parts.

See manual 312374 for two-button interlock parts.

\* Not shown.

**Relief Valve Part (99)**

Part	For Systems With Pump Part (Pump Ratio)	
<b>103347</b>	P05xxx (5:1)	P32xxx (32:1)
	P06xxx (6:1)	P34xxx (34:1)
	P10xxx (10:1)	P36xxx (36:1)
	P11xxx (11:1)	P38xxx (38:1)
	P12xxx (12:1)	P39xxx (39:1)
	P14xxx (14:1)	P40xxx (40:1)
	P15xxx (15:1)	P44xxx (44:1)
	P20xxx (20:1)	P45xxx (45:1)
	P22xxx (22:1)	P46xxx (46:1)
	P23xxx (23:1)	P55xxx (55:1)
	P26xxx (26:1)	P57xxx (57:1)
	P29xxx (29:1)	P61xxx (61:1)
	P31xxx (31:1)	P63xxx (63:1)

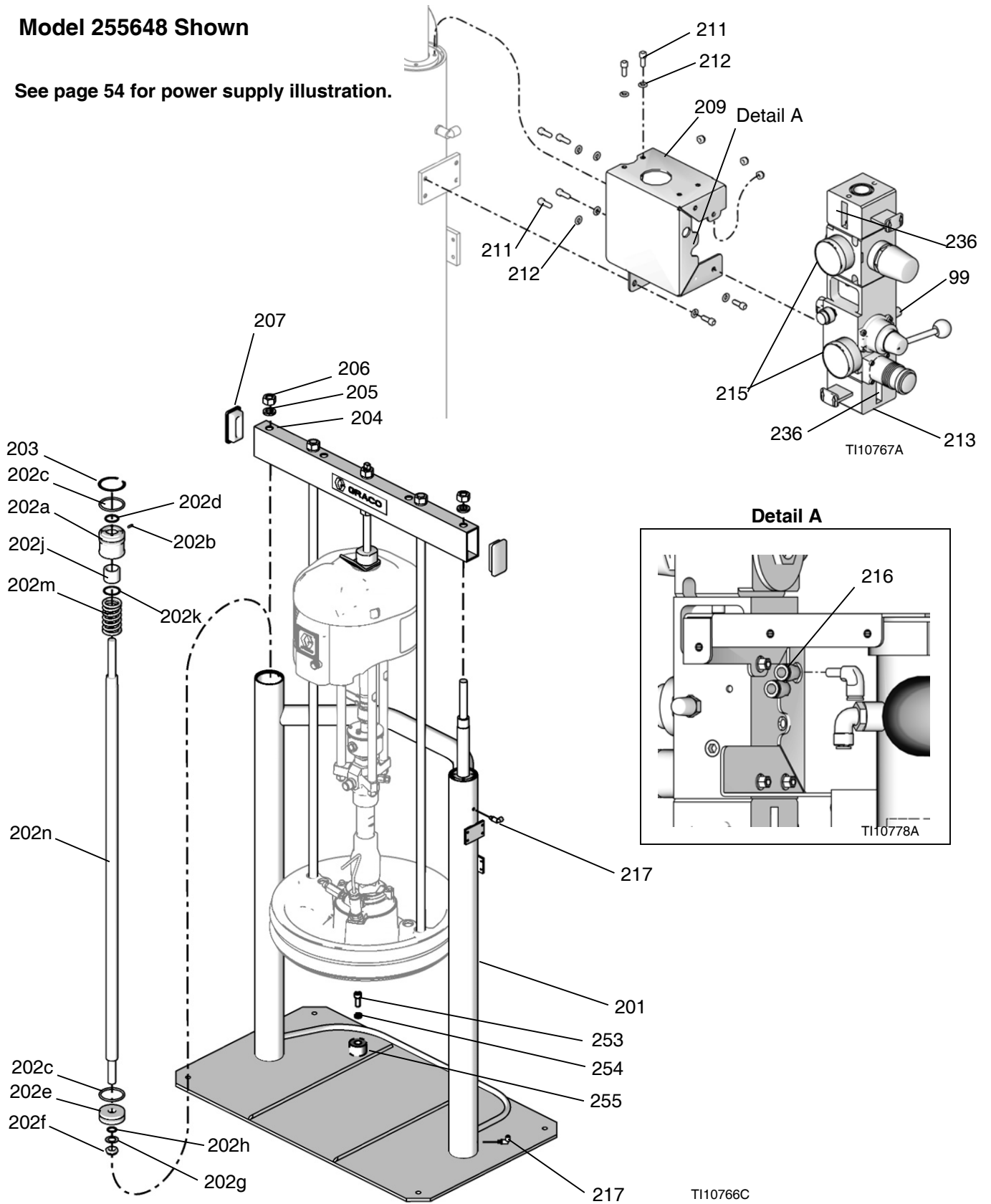
Part	For Systems With Pump Part (Pump Ratio)
<b>120306</b>	P67xxx (67:1)
<b>116643</b>	P68xxx (68:1)
<b>108124</b>	P82xxx (82:1)



# D200 3 in. Supply Units

Model 255648 Shown

See page 54 for power supply illustration.



**D200 3 in. Supply Units, 255648**

Ref.	Part	Description	Qty.
201		RAM, 3 in.	1
202		PISTON, assembly 3 in. ram; includes 202a - 202m	2
202a		BEARING, ram end cap	2
202b	107092	PIN, spring, straight	2
202c*	160258	O-RING	4
202d*	156698	O-RING	2
202e	183943	PISTON	2
202f*		NUT, jam	2
202g*		WASHER, split	2
202h*	156401	O-RING	2
202j*		BEARING, ram end cap	2
202k*		RETAINER, retaining ring	2
202m*		SPRING, compression	2
202n	167651	ROD, piston, ram	2
203*	127510	RING,retaining	2
204	167646	BEAM, tie	1
205	101533	WASHER, spring lock	2
206	101535	NUT, full hex	2
207	189559	CAP, end	2
209		BRACKET, mounting, air control	1
211	101682	SCREW, cap, sch	8
212	100016	WASHER, lock	8
213	255650	CONTROL, air; see 312374	1
215	101689	GAUGE, pressure, air	2
216	132848	ELBOW, plug in	3
217	128863	ELBOW	2
220✘	C12509	TUBE, nylon, 14.60 in. (370.84 mm)	1
236▲	15V954	LABEL	1
253	C19853	SCREW, cap, socket, hd	2
254	C38185	WASHER, lock	2
255	C32467	STOP, drum	2
256▲✘	15J074	LABEL, safety	2
99		VALVE, safety relief; see page 40	1

▲ *Replacement Danger and Warning labels, tags, and cards are available at no cost.*

\* *Parts included in Supply Units Repair Kit 255687 (purchase separately).*

✘ *Not shown.*

*See **Power Supply - D200s, D200, D60, and S20 3 in. Supply Unit** on page 54 for 24 VDC and 100-240 VAC power supply parts.*

*See manual 312374 for two-button interlock parts.*

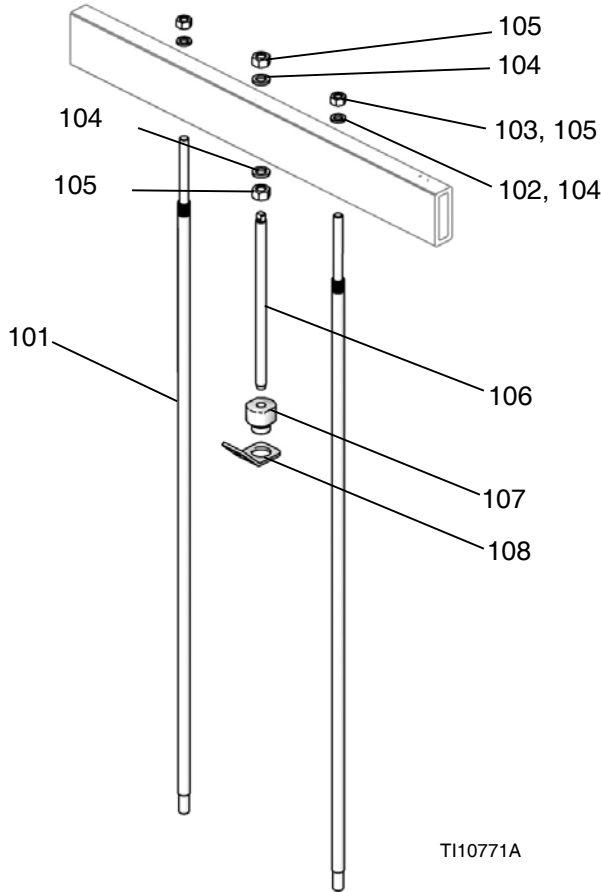
# D200s and D200 Pump Mounts for 55 Gallon (200 Liter) Platen

**Kits - 255315, 255305, and 256235**

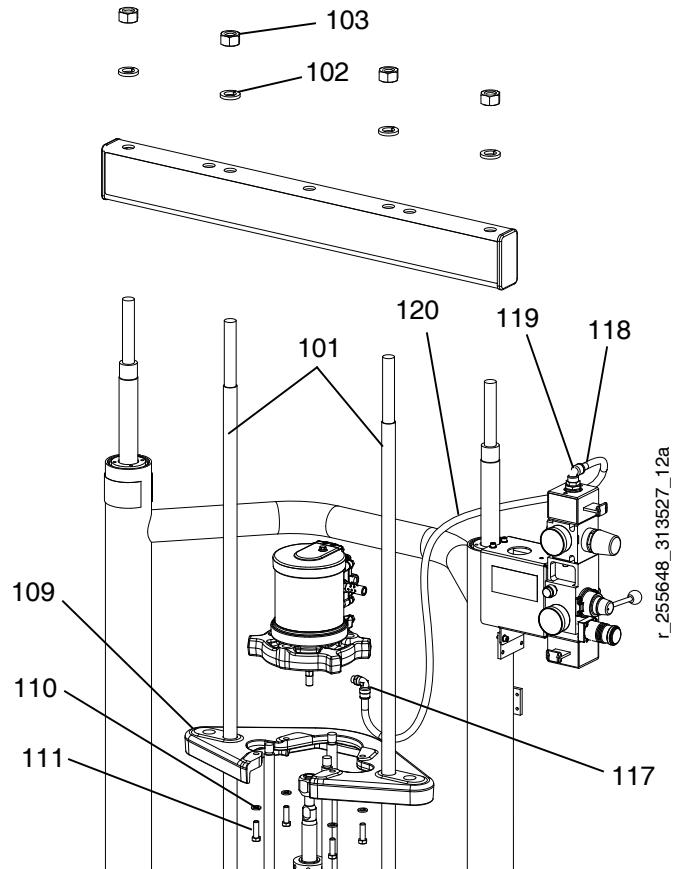
**Kits - 257625 and 257627**

**Note:** See page 38 for kit configuration table.

**Note:** See page 38 for kit configuration table.



T110771A



r\_255648\_313527\_12a

Ref.	Part	Description
101	15M531✓	ROD, platen
	167652✱*	
102	101015✓	WASHER, lock
103	C19187✓	NUT, hex
104	101533	WASHER, spring lock
105	101535	NUT, full hex
106	15M399✓	ROD, threaded
	15J992✱*	ROD, threaded
107	15J991	ADAPTER, lift, ring
108	15J993	RING, lift, plate
124✱	160327	FITTING, 3/4 nptf x 3/4 npsm, 90°
125✱	C12034	HOSE, coupled; 72 in.
126✱	552071	SLEEVE, protective, 6 ft
127✱	105281	FITTING, 3.4 nptf x 3/4 npsm, 45°

✓ Pump Mount 255315 only.

✱ Pump Mount 255305 only.

\* Pump Mount 256235 only.

✱ Not shown.

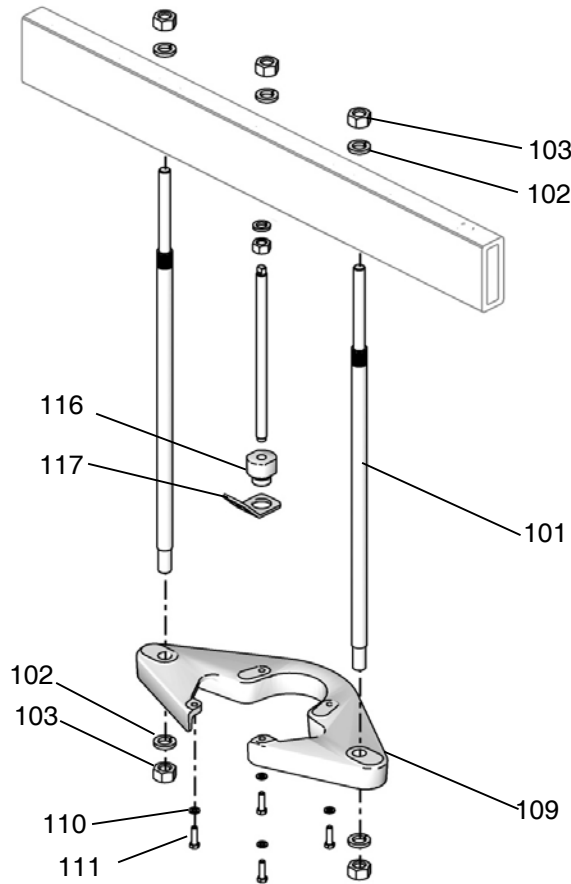
Qty.	Ref.	Part	Description	Qty.
2	101	167652	ROD, platen	2
2	102	101533	WASHER, spring lock	2
2	103	101535	NUT, hex	2
1	109		BRACKET, shelf	1
4	110	100133	WASHER, lock	4
4	111		SCREW, cap, hex hd	4
1	117	114128	ELBOW, swivel, male; 257627 only	1
1	118	100896	BUSHING, pipe	1
1	119		ELBOW, 1/2 OD x 1/2 in. npt	1
1	120	061513	TUBE, nylon, 1/2 OD x 3/8 ID; 45 in.	1
1	121✱		SLEEVE, protective; 45 in.	1
2	122✱		STRAP, tie	2
2	123✱		HOLDER, cable tie, rotating	2

✱ Not shown.

# D200s and D200 Pump Mounts for 5 Gallon (20 Liter), 8 Gallon (30 Liter), 16 Gallon (60 Liter), and 30 Gallon (115 Liter) Platens

Kits - 255316, 255317, 255308, 255309

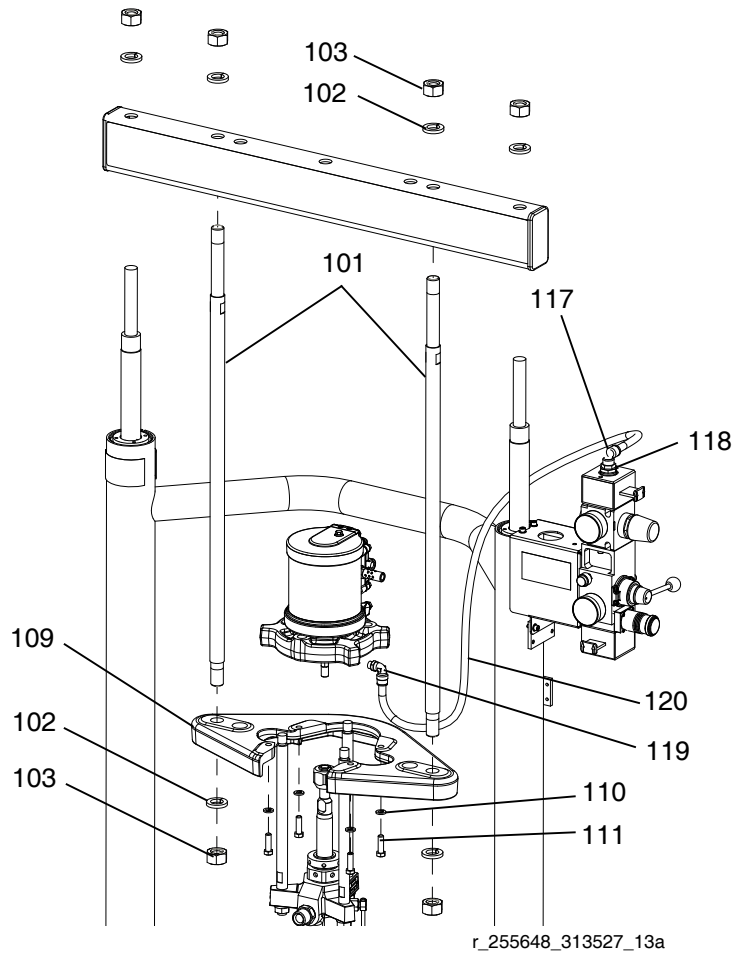
**Note:** See page 38 for kit configuration table.



Ref.	Part	Description	Qty.	
101	15M298◆ 15M297‡	ROD, tie bar, shelf	2	◆ Pump Mounts 255316 and 255317 only. ‡ Pump Mounts 255308 and 255309 only.
102	101015◆ 101533‡	WASHER, lock	4	✖ Not shown.
103	C19187◆ 101535‡	NUT, hex	4	
109		BRACKET, shelf 6500, 3400; 255316 and 255308 only BRACKET, shelf 2200; 255317 and 255309 only	1 1	
110	100133	WASHER, lock	4	
111		SCREW, cap, hex hd	4	
115		ROD, threaded	1	
116		ADAPTER, lift, ring	1	
117		RING, lift, plate	1	
124✖	160327	FITTING, union adapter, 90°	1	
125✖	C12034	HOSE, coupled; 72 in.	1	
126✖	552071	SLEEVE, protective, 6 ft	1	
127✖	105281	FITTING, 3.4 nptf x 3/4 npsm, 45°	1	

**Kits - 257626 and 257628**

**Note:** See page 38 for kit configuration table.



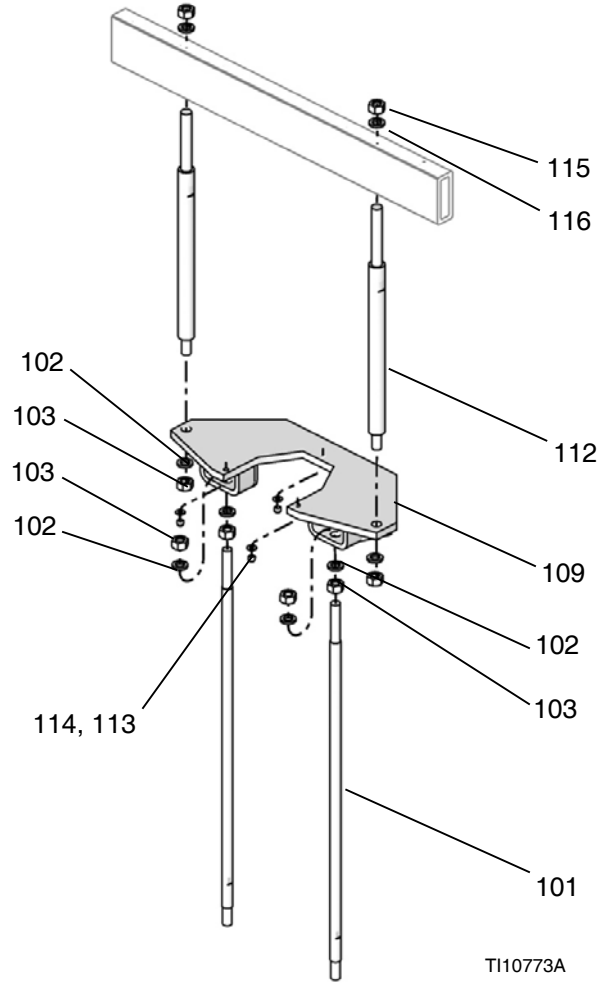
r\_255648\_313527\_13a

Ref.	Part.	Description	Qty.
101	257726	ROD, tie bar, shelf	2
102	101533	WASHER, spring lock	4
103	101535	NUT, hex	4
109		BRACKET, shelf	1
110	100133	WASHER, lock	4
111		SCREW, cap, hex hd	4
117	114128	ELBOW, swivel, male; 257628 only	1
118	100896	BUSHING, pipe	1
119		ELBOW, 1/2 OD x 1/2 in. npt	2
120	061513	TUBE, nylon, 1/2 OD x 3/8 ID; 45 in.	1
121	✘	SLEEVE, protective; 45 in.	1
122	✘	STRAP, tie	2
123	✘	HOLDER, cable tie, rotating	2

✘ Not shown.

**Pump Mount 255306 (Xtreme XL motors on 6.5 in. supply units only)**

**Note:** See page 38 for kit configuration table.



TI10773A

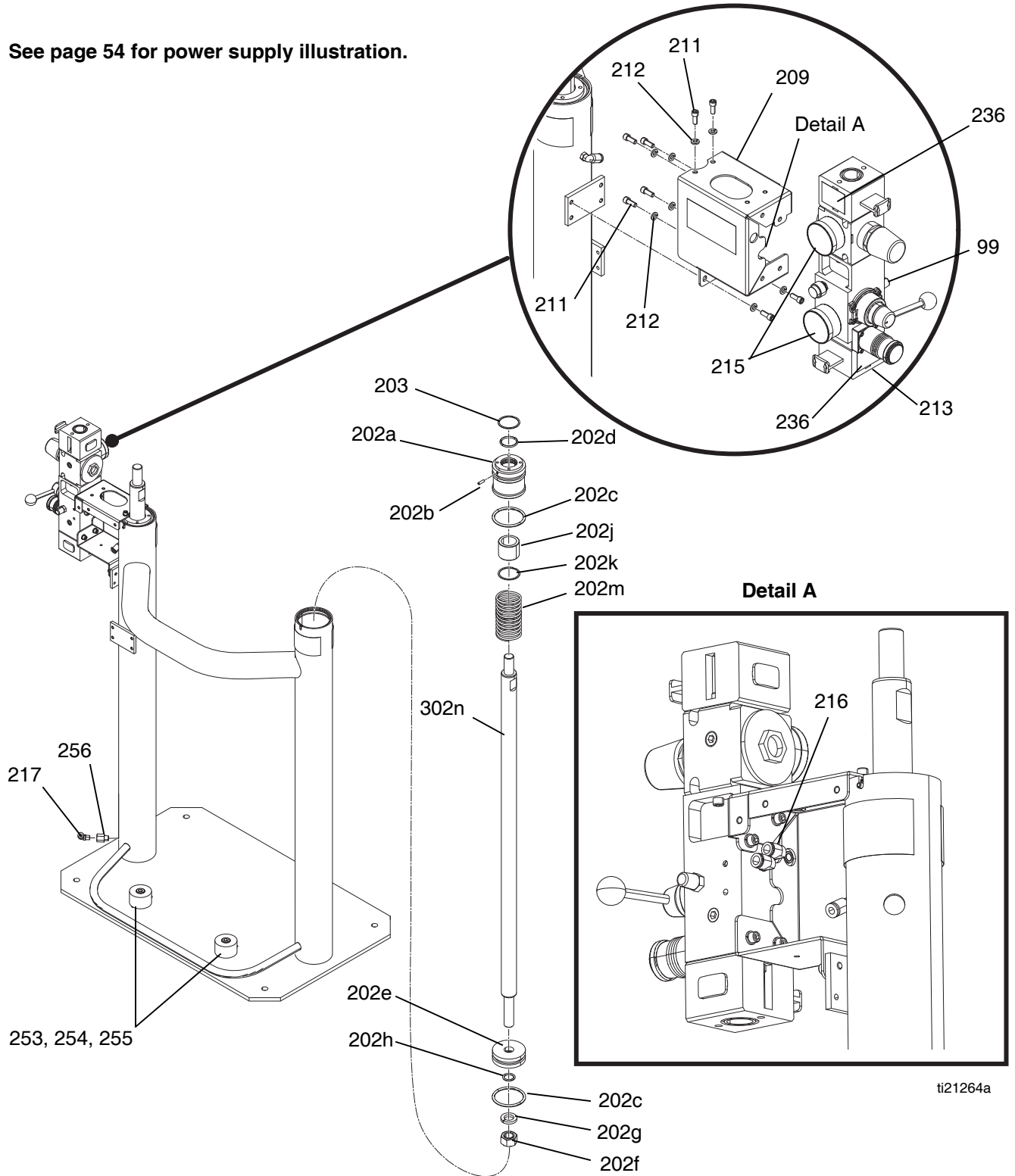
Ref.	Part	Description	Qty.
101	15M686	ROD, lower, platen	2
102	101533	WASHER, spring lock	6
103	101535	NUT, full hex	6
109	617193	PLATE, pump mounting	1
112	617275	ROD, upper tie #(cold cm2100)	2
113	100023	WASHER	3
114	101566	NUT, lock	3
115	113939	NUT, jam, hex	2
116	113993	WASHER, lock, helical	2
124	✘	FITTING, union adapter, 90°	1
125	✘	HOSE, coupled; 72 in.	1
126	✘	SLEEVE, protective, 6 ft	1
127	✘	FITTING, 3.4 nptf x 3/4 npsm, 45°	1

✘ Not shown.

# D60 3 in. Dual Post Supply Unit

Model 257621 Shown

See page 54 for power supply illustration.



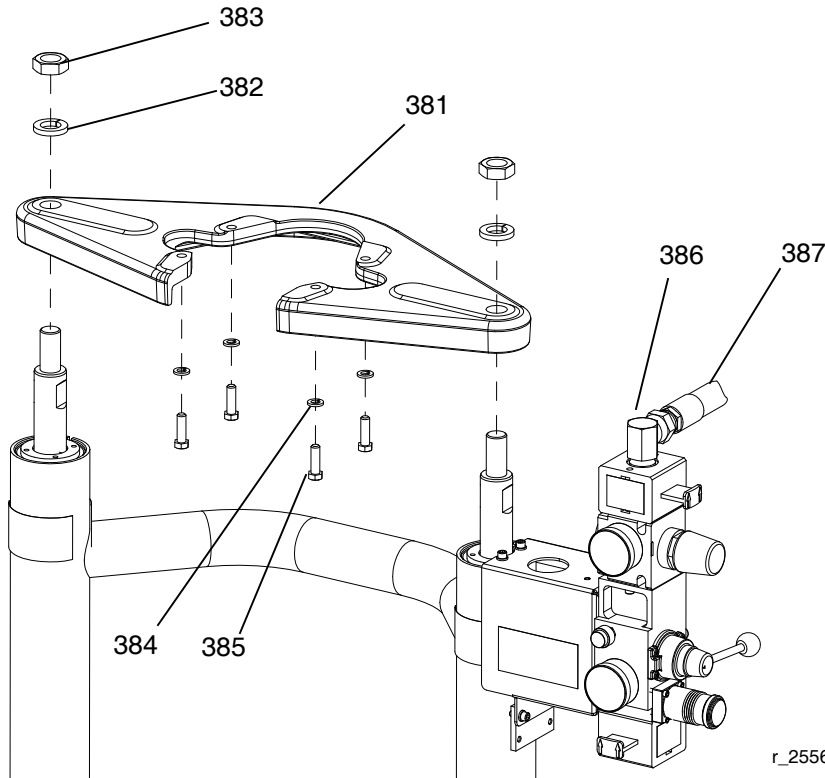
ti21264a

**D60 3 in. Supply Units, 257621**

Ref.	Part	Description	Qty.	Ref.	Part	Description	Qty.
202		PISTON, ram, subassembly; includes 202a-202m	1	216	132848	ELBOW, plug in	2
202a*		BEARING, ram end cap	2	217	128863	ELBOW	2
202b*	107092	PIN, spring, straight	2	236▲	15V954	LABEL, valve shutoff air control	4
202c*		O-RING	4	253	C19853	SCREW, cap, socket hd	2
202d*		O-RING	2	254	C38185	WASHER, lock	2
202e*	183943	PISTON	2	255	C32467	STOP, drum	2
202f*		NUT, jam	2	256	16T421	ADAPTER, pipe hex; 5/8 in.	1
202g*		WASHER, split	2	99		VALVE, safety relief; see page 40	1
202h*		O-RING	2	▲ <i>Replacement Danger and Warning labels, tags, and cards are available at no cost.</i>			
202j*		BEARING, ram end cap	2	❖ <i>Not shown.</i>			
202k*		RETAINER, retaining ring	2	* <i>Parts included in Supply Units Repair Kit 257622 (purchase separately).</i>			
202m*		SPRING, compression	2	<i>See Power Supply - D200s, D200, D60, and S20 3 in. Supply Unit on page 54 for 24 VDC and 100-240 VAC power supply parts.</i>			
302n*	15V697	ROD, piston, ram	2	<i>See manual 312374 for two-button interlock parts.</i>			
203*	127510	RING, retaining, 3.06 dia	2				
301		RAM	1				
209		BRACKET, mounted	1				
211	101682	SCREW, cap, sch	8				
212	100016	WASHER, lock	8				
213	255650	CONTROL, air; see manual 312374	1				
215	101689	GAUGE, pressure, air	2				

# D60 Pump Mounts 257623 and 257624 for 5 Gallon (20 Liter), 8 Gallon (30 Liter), and 16 Gallon (60 Liter) Platens

**Note:** See page 38 for kit configuration table.



r\_255648\_313527\_15a

Ref.	Part	Description	Qty.
381	‡ ✿	BRACKET, shelf, NXT2200 BRACKET, shelf, NXT3400 and NXT6500	1
382	101533	WASHER, spring lock	2
383	101535	NUT, hex	2
384	100133	WASHER, lock	4
385	C38372	SCREW, cap, hex head	4
386	105281	FITTING, 3.4 nptf x 3/4 npsm, 45°	1
387	C12034	HOSE, coupled 72 in.	1
388	✗	SLEEVE, protective; 72 in.	1
389	✗	STRAP, tie	2
390	✗	HOLDER, cable tie, rotating	2
391	✗ 160327	FITTING, 3/4 nptf x 3/4 npsm, 90°	1

‡ For 257623 only.

✿ For 257624 only.

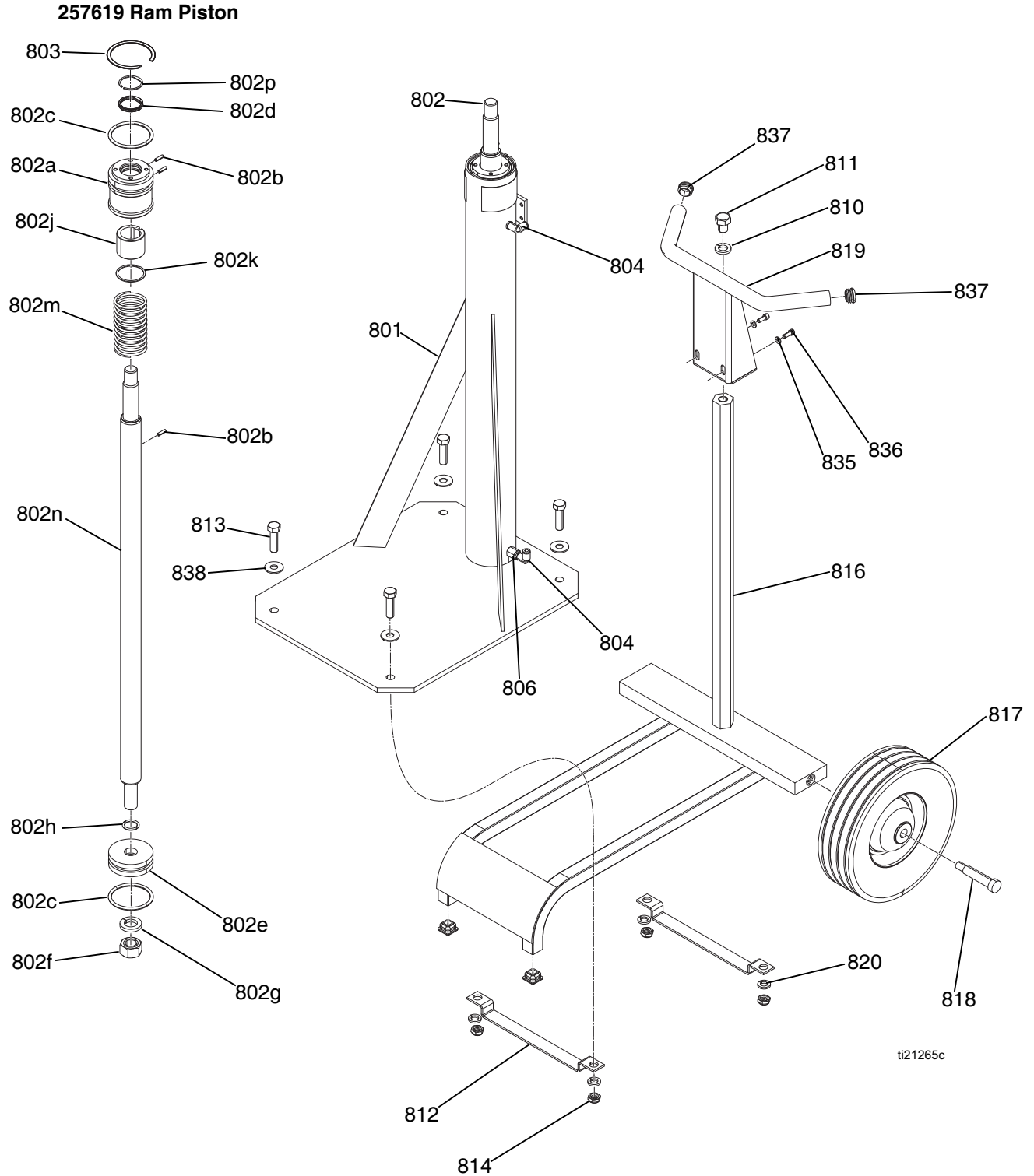
✗ Not shown.



# S20 3 In. Single Post Ram

## S20 Single Supply Unit Cart Shown

See page 54 for power supply illustration.



**S20 Single Supply Unit, 257620**

Ref.	Part	Description	Qty.	Ref.	Part	Description	Qty.
801		RAM	1	802k	15F453	RETAINER, retaining ring 1.88 bore	1
802	257619	PISTON, S20 ram, subassembly; includes 802a-802p	1	802m	160138	SPRING, compression	1
802a	15V032	BEARING, rod top	1	802n	15U202	ROD, ram, w/flat	1
802b	15U979	PIN, spring, straight	3	802p	15U006	SPACER, d seal backup ring	1
802c	160258	O-RING	2	803	127510	RING, retaining, 3.06 dia	1
802d	15U189	SEAL, d-shaped u cup	1	804	128863	FITTING, elbow	2
802e	183943	PISTON	1	805▲	15J074	LABEL, safety, crush & pinch	2
802f	101535	NUT, hex	1	806	16T421	ADAPTER, pipe hex; 5/8 in.	1
802g	101533	WASHER, spring lock	1	99		VALVE, safety relief; see page 40	1
802h	156401	O-RING	1				
802j	15U546	BEARING, ram end cap max flat	1				

▲ Replacement Danger and Warning labels, tags, and cards are available at no cost.

**S20 Single Supply Unit Cart Kit, 257618**

Ref.	Part	Description	Qty.
805▲		LABEL, safety, crush & pinch	2
816		CHASSIS, elevator	1
817		WHEEL, semi pneumatic	2
818		BOLT, 5/8 x 2-1/2 shoulder	2
819		HANDLE	1
810		WASHER, lock	1
811		BOLT, hex hd	1
812		BRACKET, cart	2
813		SCREW, cap, hex hd	4
814		NUT, hex	4
815		CAP, tube, square	4
820		WASHER, lock	4
835		WASHER, lock	2
836		SCREW, cap, sch	2
837		CAP, handle	2
838		WASHER, wrought	4

▲ Replacement Danger and Warning labels, tags, and cards are available at no cost.

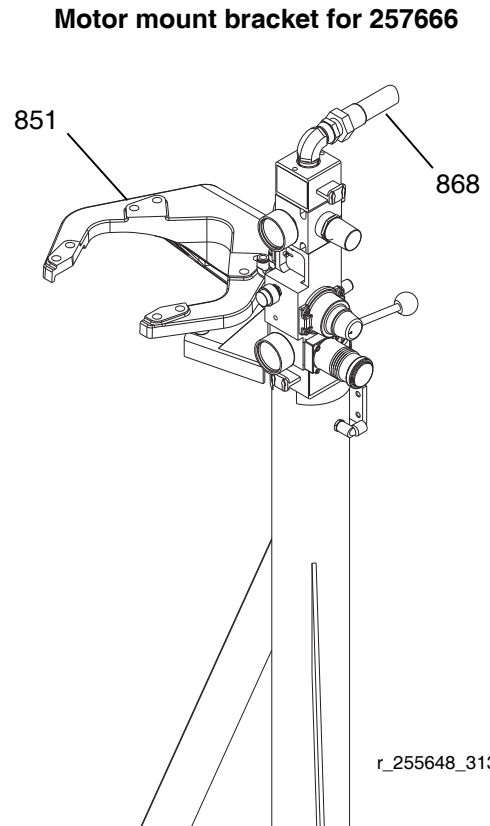
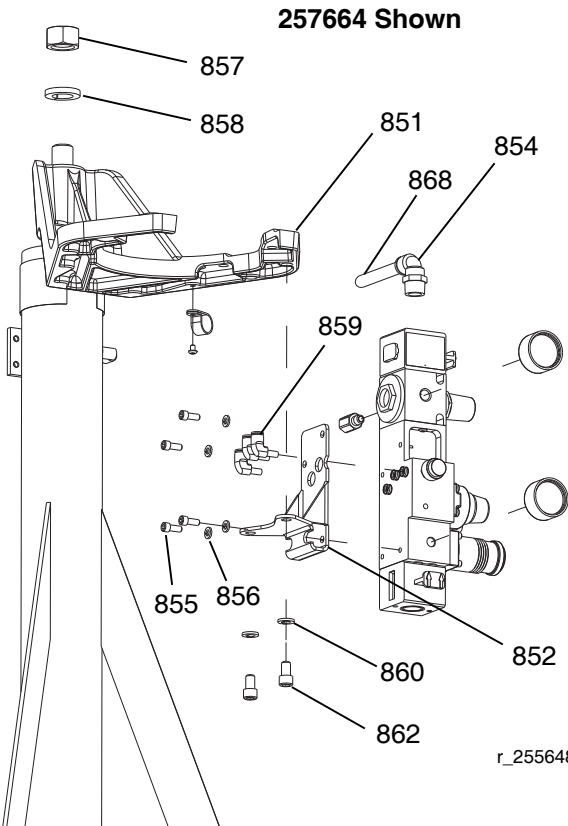
See **Power Supply - D200s, D200, D60, and S20 3 in. Supply Unit** on page 54 for 24 VDC and 100-240 VAC power supply parts.

# S20 3 In. Single Post Ram Mounting Kit

257664 - For NXT200 and NXT400 NXT700, NXT1200, and NXT 1800

257666 - For NXT2200 and NXT3400

257612 - Air controls sold separately for S20 ram. Includes 2 gauges (113911) and 2 labels (15V954).



Ref.	Part	Description	Qty.
851	† ★	BRACKET, motor mount	1
852		BRACKET, controls	1
854	† ★★	ELBOW, swivel	1
		ELBOW, swivel	2
855		SCREW, cap, sch	4
856		WASHER, lock	4
857		NUT, cap	1
858		WASHER, spring lock	1
859		ELBOW, plug in	3
860		WASHER, lock	6
861		SCREW, cap, socket hd	4
862		SCREW, cap, socket head	2
864		TUBE, nylon, rnd; 16 in.	1
865	✘	SLEEVE, protective	5
866	✘	HOLDER, cable tie, rotating	1
867	✘	STRAP, tie	2
868	✘	HOSE	1
	★		
869	✘	ADAPTER	1
871	✘ †	ADAPTER, elbow, 3/4 npti x 1/2 npte	1
880	✘ ★	ELBOW, swivel, 3/8T x 1/4 npt(m)	

▲ Replacement Danger and Warning labels, tags, and cards are available at no cost.

† For 257666 only.

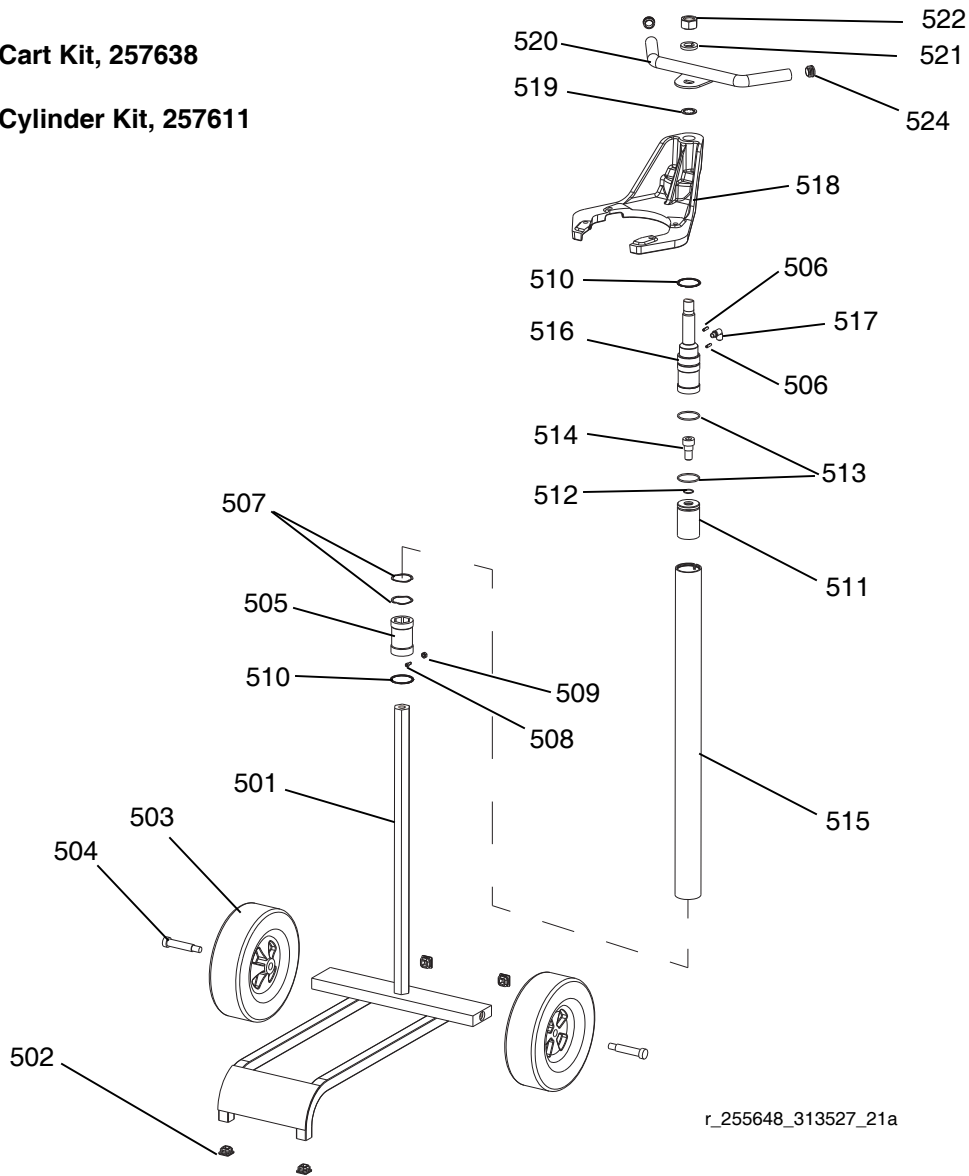
★ For 257664 only.

✘ Not shown.

# L20c 2 In. Elevator

L20c Cart Kit, 257638

L20c Cylinder Kit, 257611



r\_255648\_313527\_21a

Ref.	Part	Description	Qty.
501‡	15V711	CHASSIS, elevator	1
502‡	116895	PLUG	4
503‡	106062	WHEEL, semi-pneumatic	2
504‡	15V529	BOLT, 5/8 x 2-1/2 shoulder	2
505★	15V349	BEARING	1
506★	15U979	PIN, spring, straight	2
507★	15V450	SPRING, wave	2
508★	102598	SCREW, cap, sch	1
509★	114231	NUT, lock, hex	1
510	15V449	RING, retaining (for Series A only)	2
510★	125179	RING, retaining (for Series B only)	2
511★	15V348	PISTON	1
512★	514279	O-RING, 018 buna	1
513★	166238	PACKING, o-ring	2
514★	122222	FASTENER, shoulder screw, 5/8-11	1
515★	15V353	CYLINDER	1

Series A, 2.25 in. outer diameter  
Series B, 2.375 in. outer diameter

Ref.	Part	Description	Qty.
516★	15V357	CAP, end	1
517★	128863	FITTING, ELBOW	1
518★	15U376	BRACKET, motor mount	1
519★	113348	WASHER, lock, internal	1
520★	256759	HANDLE	1
521★	101533	WASHER, spring lock	1
522★	101535	NUT, cap	1
523▲	15V557	LABEL, elevator	1
524★	15X429	HANDLE, cap	2

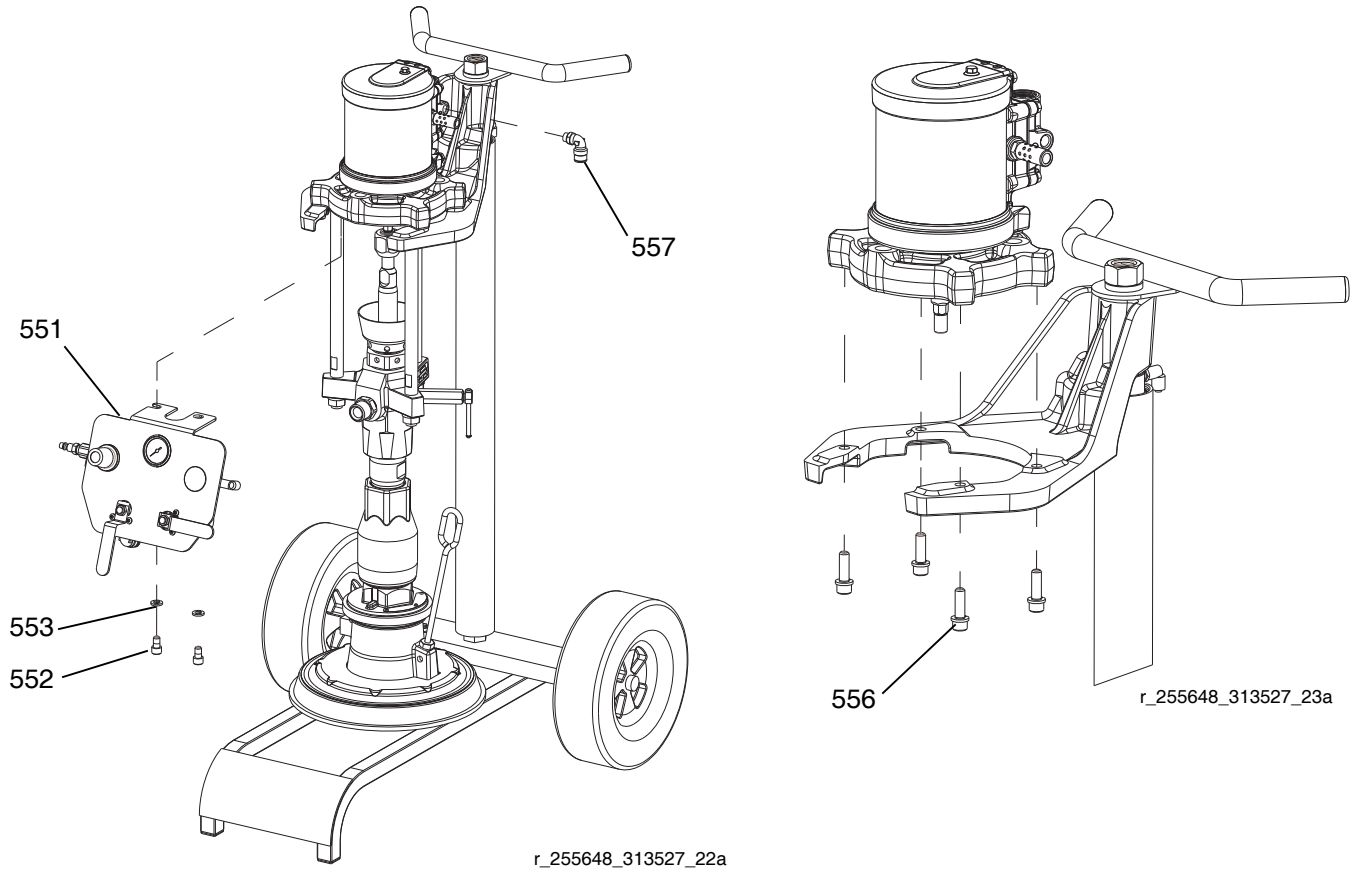
▲ Replacement Danger and Warning labels, tags, and cards are available at no cost.

‡ Included in repair kit 257638.

★ Included in kit 257611.

# Air Control Kit- L20c 2 In. Elevator

257613 - For NXT200, NXT400, NXT700, NXT1200, and NXT1800



Ref.	Part	Description	Qty.
551		PANEL, air control; see manual 312374	1
552		SCREW, cap, socket head	2
553		WASHER, lock	6
554✘		TUBE, nylon, rnd; 52 in.	1
555✘		TUBE, nylon, 1/2 OD X 3/8 ID; 25 in.	1
556		SCREW, cap, socket hd	4
557		ELBOW, male, swivel	1
		ELBOW, male, swivel, 1/2 npt x 1/2 tube	1

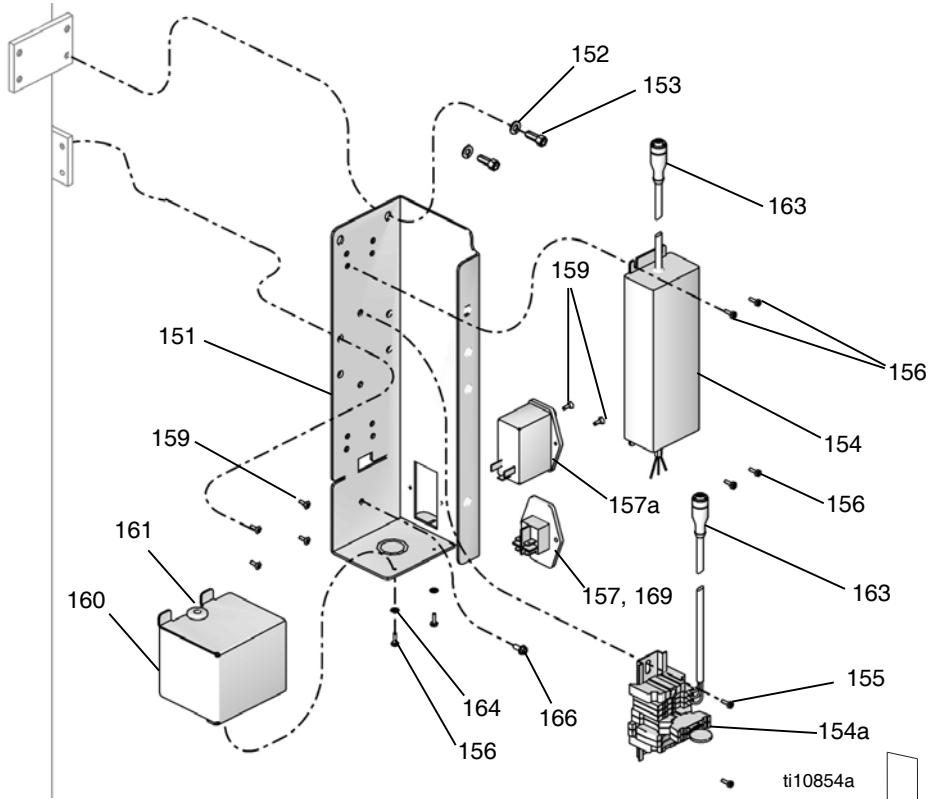
▲ Replacement Danger and Warning labels, tags, and cards are available at no cost.

✘ Not shown.

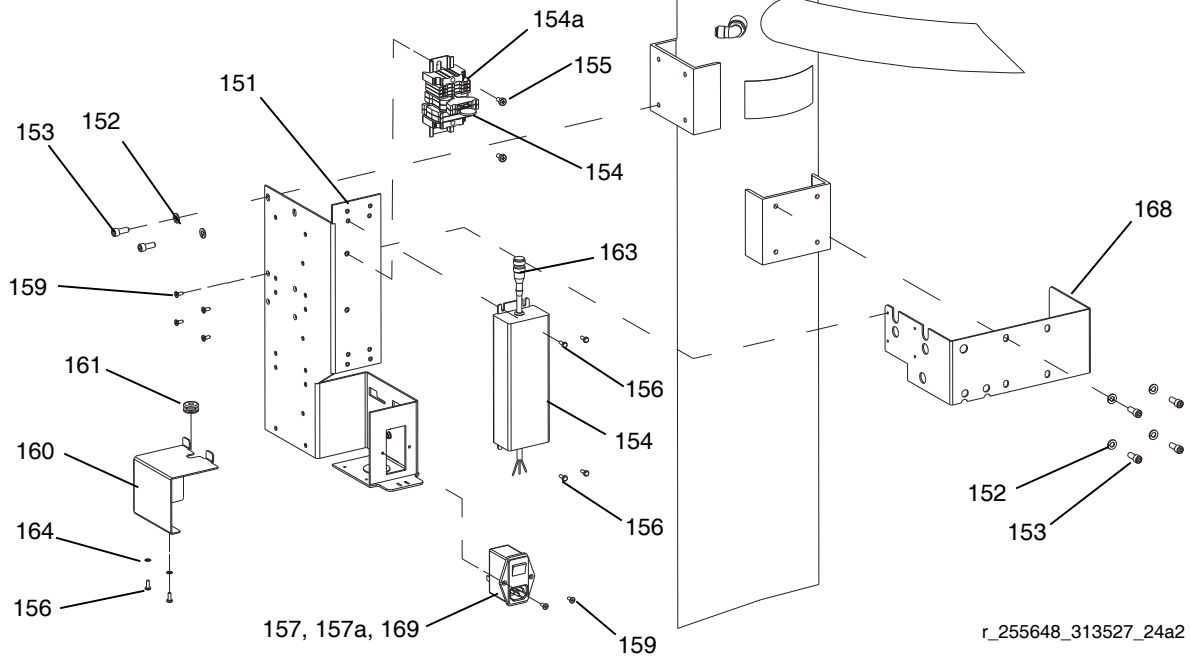
# Power Supply - D200s, D200, D60, and S20 3 in. Supply Unit

Both 24 VDC and 100-240 VAC Power Supplies Shown

## Power Supplies on S20



## Power Supplies on D200s, D200, and D60



r\_255648\_313527\_24a2

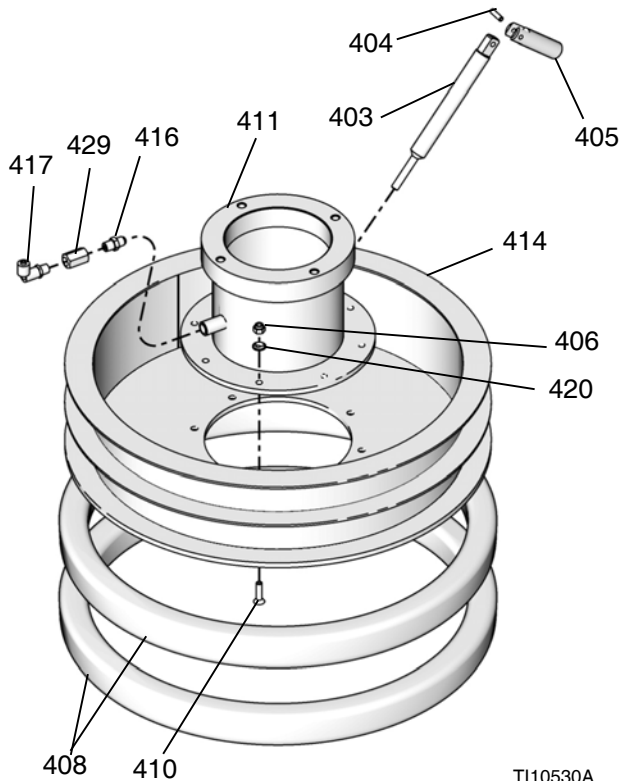
## 24 VDC and 100-240 VAC Power Supply Parts

Ref.	Description	(24 VDC)			(100-240 VAC)			Qty.
		S20	D60	D200s D200	S20	D60	D200s D200	
151	ENCLOSURE, power supply assy	n/a	n/a	n/a	n/a	n/a	n/a	1
152	WASHER, lock	100016	100016	100016	100016	100016	100016	6
153	SCREW, cap, sch	101682	101682	101682	101682	101682	101682	6
154	MODULE, assembly, 24V	255649	255649	255649				1
154a	POWER SUPPLY, 100-240 VAC				15M293	15M293	15M293	1
155	SCREW, mach, pan head	110637	110637	110637				2
156	SCREW, self-tapping				101845	101845	101845	6
157	SWITCH, power, 24 VDC	n/a	n/a	n/a				1
157a	SWITCH, power, 120V				121254	121254	121254	1
158	COVER, switch mount				n/a	n/a	n/a	1
159	SCREW, countersunk, 6-32 x 0.38	121255	121255	121255	121255	121255	121255	6
160	COVER, power				n/a	n/a	n/a	1
161	GROMMET				112738	112738	112738	1
162▲	LABEL, caution				196548	196548	196548	1
163	CABLE, power, female,.8M	255673	255673	255673				1
164	WASHER, lock				100272	100272	100272	2
165	FUSE, 250V / 1.2A				121261	121261	121261	2
166	SCREW, grounding				111593	111593	111593	1
167▲	LABEL, symbol, ground				186620	186620	186620	1
168	BRACKET, power supply support		n/a	n/a		n/a	n/a	
169	PLATE, switch mount	n/a	n/a	n/a				1

Parts designated n/a are not available separately.

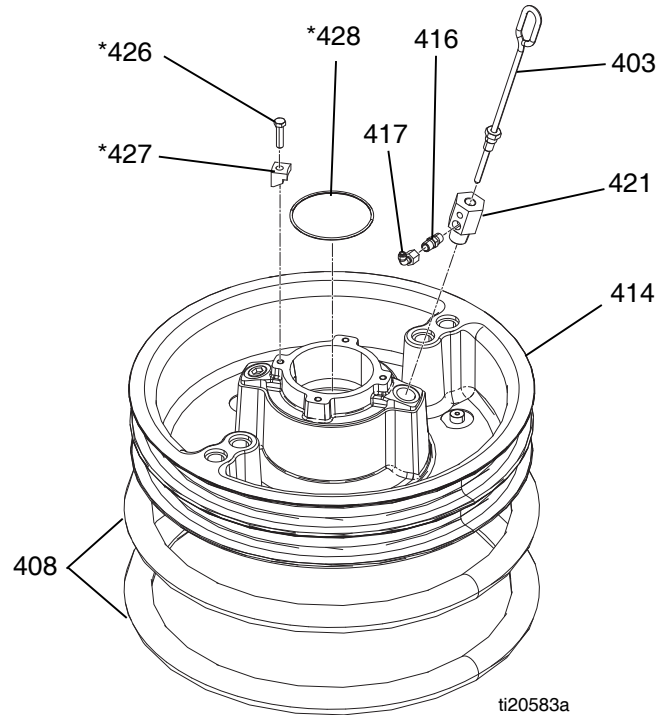
## 30 and 55 Gallon Platen

### 115 Liter (30 Gallon) Platen, Model 255661



T110530A

### 200 Liter (55 Gallon) Platen, 255662, 255663, 255664, 25N344, 273233



ti20583a

### 115 Liter (30 Gallon) Platen Parts

Ref.	Part	Description	Qty.
403	166560	STEM, probe	1
404	101831	PIN, spring	1
405	177542	HANDLE	1
406	102040	NUT, lock, hex	8
408	255654	WIPER, seal	1
410	109469	SCREW, machine flat hd	8
411		ADAPTER, 30 gal.	1
414		PLATE, follower, 30 gal.	1
416	114317	VALVE, check	1
417	128863	FITTING, elbow	1
420	C20521	SEAL, thread	8
429	100451	COUPLING	1

### 200 Liter (55 Gallon) Platen Parts

Ref.	Part	Description	Qty.
403	257697	HANDLE, bleed assy	1
408◆	255652	SEAL, wiper, drum, 55 gal., neoprene; for 255664 only.	2
	255653	SEAL, wiper, drum, 55 gal., EPDM; for 255663 and 255662 only.	2
	24X384	SEAL, wiper, drum, 55 gal., neoprene (small) for 273233 only	2
414		PLATE, ram 55 gal., for 255664 and 255663 only.	1
		PLATE, ram 55 gal., PTFE	1
416	122056	VALVE, check, 1/4, for 255662 and 255663 only	1
	501867	VALVE, check, 5/8, for 255664 only	1
417	17E556	FITTING, TUBE, quick disconnect	1
421	15W032	ADAPTER, for 255663, 255664, and 25N344	1
	16W974	ADAPTER, for 255662 only	1
426*⚡◆	102637	SCREW, cap	4
427*⚡◆	276025	CLAMP	4
428*⚡◆	109495	O-RING	1

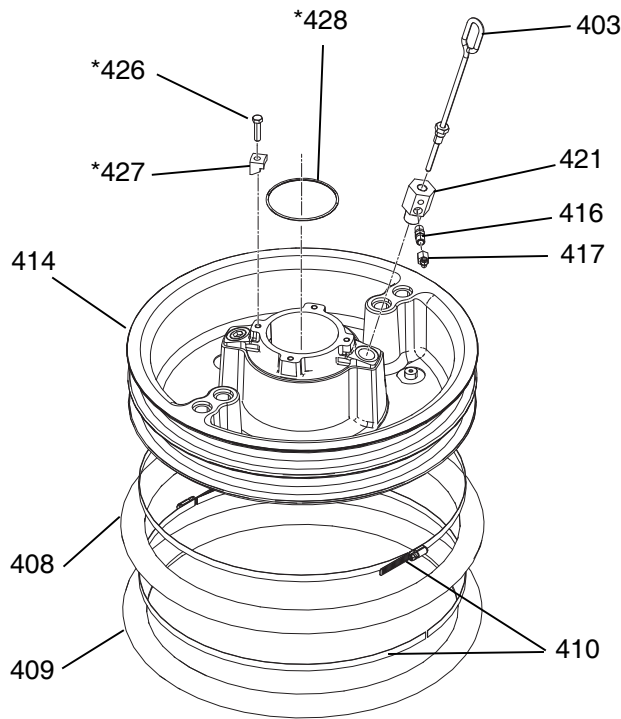
\* Parts included in 255392 Kit (purchase separately).

⚡ Parts not included with 255662, 663, and 664.

◆ Parts not included with 25N344.



### 200 Liter (55 Gallon) Platen with EPDM Hose Wipers, 24Y343



ti27403a

### 200 Liter (55 Gallon) Platen with EPDM Hose Wipers Parts

Ref.	Part	Description	Qty.
403	257697	HANDLE, bleed assy	1
408†	17L889	SEAL, wiper, drum, 55 gal., EPDM	1
409†	162230	SEAL, wiper, drum, 55 gal., EPDM	1
410†	17B467	CLAMP, tire	4
414		PLATE, ram 55 gal.	1
416	122056	VALVE, check, 1/4	1
417	17E556	FITTING, TUBE, quick disconnect	1
421	15W032	ADAPTER	1
426*⊗	102637	SCREW, cap	4
427*⊗	276025	CLAMP	4
428*⊗	109495	O-RING	1

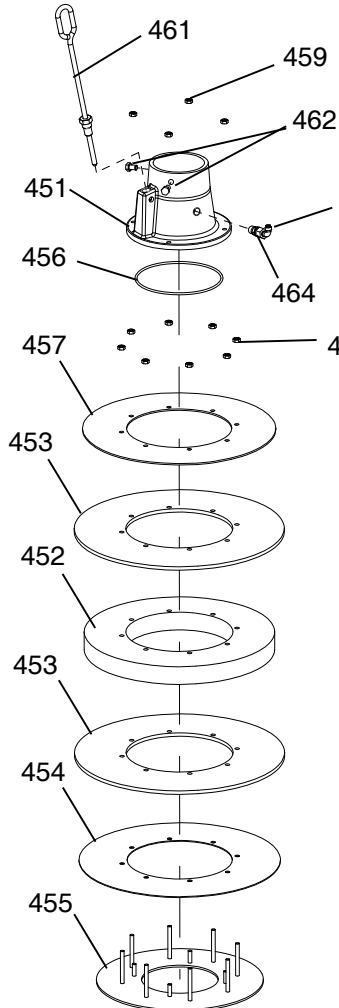
\* Parts included in 255392 Kit (purchase separately).

† Parts included in 25M210 Kit (purchase separately).

⊗ Parts not included with 24Y343.

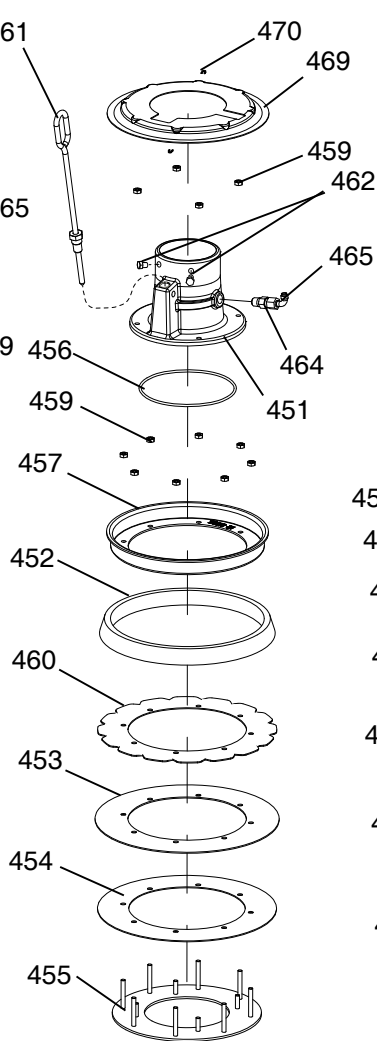
# 20 Liter (5 Gallon), 30 Liter (8 Gallon), and 60 Liter (16 Gallon) Platens

Double Wiper Platen



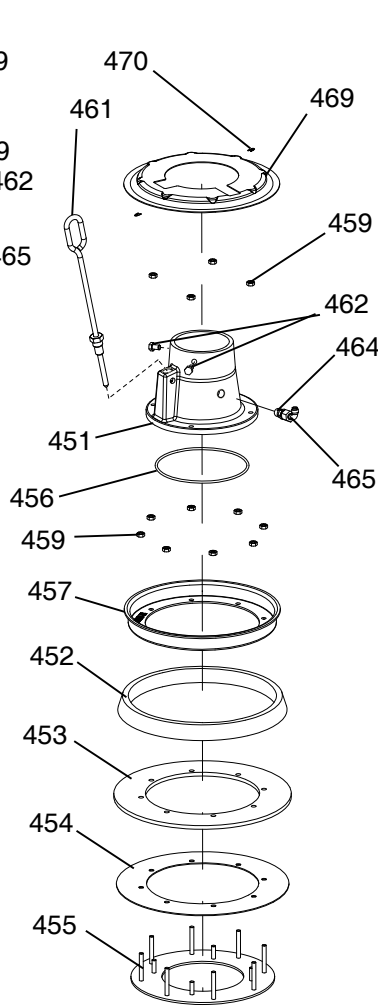
r\_255648\_313527\_25a

Single Wiper with SST Platen



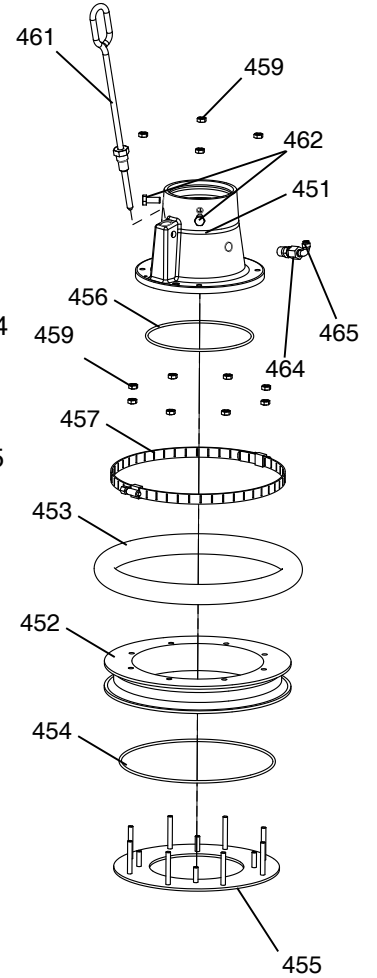
r\_255648\_313527\_34a

Single Wiper Platen



r\_255648\_313527\_26a

Single Wiper Platen PVC



## Platen Descriptions

Platen	Platen Size	Platen Material	Seal Material	Wiper Assembly Kit
257727✿	20 Liter (see page 60)	CS	Nitrile	257639
257728✿		CS	PolyUrethane	257640
257729✿		SST	PTFE-coated Nitrile	257641
257730*		CS	Nitrile	257642
257731*		CS	PolyUrethane	257643
25A206✿		SST	Nitrile (FDA Approved)	25A207
25E110✿		CS	PVC	25E111
257732✿	30 Liter (see page 60)	CS	Nitrile	257644
257733✿		CS	PolyUrethane	257645
257734✿		SST	PTFE-coated Nitrile	257646
257735*		CS	Nitrile	257647
257736*		CS	PolyUrethane	257648
257737✿	60 Liter (see page 61)	CS	Nitrile	257649
257740✿		CS	PolyUrethane	257650
257738✿		SST	PTFE-coated Nitrile	257651
257739*		CS	Nitrile	257652
257741*		CS	PolyUrethane	257653

✿ *Single wiper*

\* *Double wiper*

*See page 60-61 for parts.*

**Common Parts**

The parts listed below are common among all 20, 30, and 60 liter platens. Parts that vary are found in the tables on page 60-61.

Ref. Part	Description	Qty.
456	121829 O-RING	1
459	555413 NUT, (For SST platens)	12
	113504 NUT, keps, hex hd (For CSTL platens)	12
461	257697 HANDLE, bleed, sst	1
463	109482 O-RING; see page 61	1
465	17E556 ELBOW, 90°; 1/4 OD x 1/4 npt	1

**Varying Parts - 20 Liter (5 Gallon) Platens**

The following table indicates which parts (according to reference number) are included with each platen.

Ref.	Description	Reference Numbers							Qty:
		257727	257728	257729	257730	257731	25A206	25E110	
451	BASE	257665	257665	257662	257665	257665	257662	257665	1
452 ‡	SPACER	276049	276049	276049	257694	257694	276049	17T370	1
453 ‡	WIPER, main	257672	257678	257675	257672 (2)	257672 (2)	25A208	15W597	1 (2)
454 ‡	WIPER, PE support	257681	257681	257681	257681	257681	257681	17T371	1
455 ‡	PLATE, bottom	257668	257668	257671	257668	257668	257671	257668	1
457 ‡	PLATE, top - clamp retainer	257692	257692	257698	257686	257686	257698	C31154 (2)	1 (2)
460 ‡	WIPER, support			257689			n/a		1
462 ‡	SCREW, cap, hex hd	100057	100057	112894	100057	100057	112894		2
464	VALVE, check	122056	122056	501867	122056	122056	501867	122056	1
468 ‡	TAG, instructions	n/a	n/a	n/a			n/a	n/a	1
469 ‡	COVER	15W184	15W184	15W184			15W184		1
470 ‡	PIN, hairpin, cotter (10 pack)	16U740	16U740	16U740			16U740		2

Parts designated n/a are not available separately.

‡ See page 59 for wiper assembly kits.

**Varying Parts - 30 Liter (8 Gallon) Platens**

The following table indicates which parts (according to reference number) are included with each platen.

Ref.	Description	Reference Numbers					Qty:
		257732	257733	257734	257735	257736	
451	BASE	257665	257665	257662	257665	257665	1
452 ‡	SPACER	194148	194148	194148	257695	257695	1
453 ‡	WIPER, main	257673	257679	257676	257673 (2)	257679 (2)	1 (2)
454 ‡	WIPER, PE support	257682	257682	257682	257682	257682	1
455 ‡	PLATE, bottom	n/a	n/a	n/a	n/a	n/a	1
457 ‡	PLATE, top	n/a	n/a	n/a	n/a	n/a	1
460 ‡	WIPER, support			257690			1
462 ‡	SCREW, cap, hex hd	100057	100057	112894	100057	100057	2
464	VALVE, check	122056	122056	501867	122056	122056	1
468 ‡	TAG, instructions	n/a	n/a	n/a			1
469 ‡	COVER	15X403	15X403	15X403			1
470 ‡	PIN, hairpin, cotter (10 pack)	16U740	16U740	16U740			2

Parts designated n/a are not available separately.

‡ See page 59 for wiper assembly kits.

## Varying Parts - 60 Liter (16 Gallon) Platens

The following tables indicates which parts (according to reference number) are included with each platen.

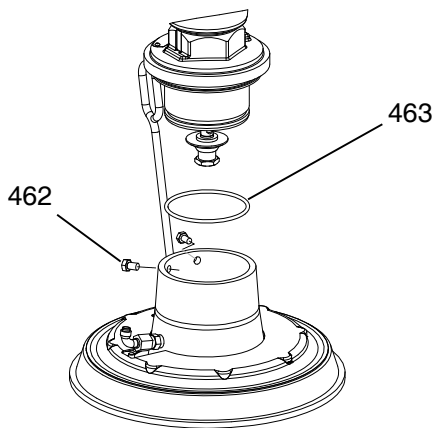
Ref.	Description	Reference Numbers					Qty:
		257737	257740	257738	257739	257741	
451	BASE	257665	257665	257662	257665	257665	1
452 <del>‡</del>	SPACER	257684	257684	257684	257696	257696	1
453 <del>‡</del>	WIPER, main	257674	257680	257677	257674 (2)	257680 (2)	1 (2)
454 <del>‡</del>	WIPER, PE support	257683	257683	257683	257683	257683	1
455 <del>‡</del>	PLATE, bottom	n/a	n/a	n/a	n/a	n/a	1
457 <del>‡</del>	PLATE, top	n/a	n/a	n/a	n/a	n/a	1
460 <del>‡</del>	WIPER, support			257691			1
462 <del>‡</del>	SCREW, cap, hex hd	100057	100057	112894	100057	100057	2
464	VALVE, check	122056	122056	501867	122056	122056	1
468 <del>‡</del>	TAG, instructions	n/a	n/a	n/a			1
469 <del>‡</del>	COVER	15X404	15X404	15X404			1
470 <del>‡</del>	PIN, hairpin, cotter (10pack)	16U740	16U740	16U740			2

Parts designated n/a are not available separately.

‡ See page 59 for wiper assembly kits.

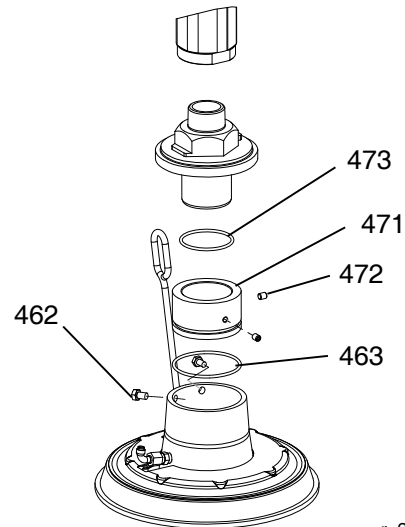
## Platen Mounting Kits

### Check-Mate Mounting



r\_255648\_3135

### Dura-Flo Mounting Kit 257630



r\_255648\_313527\_36a

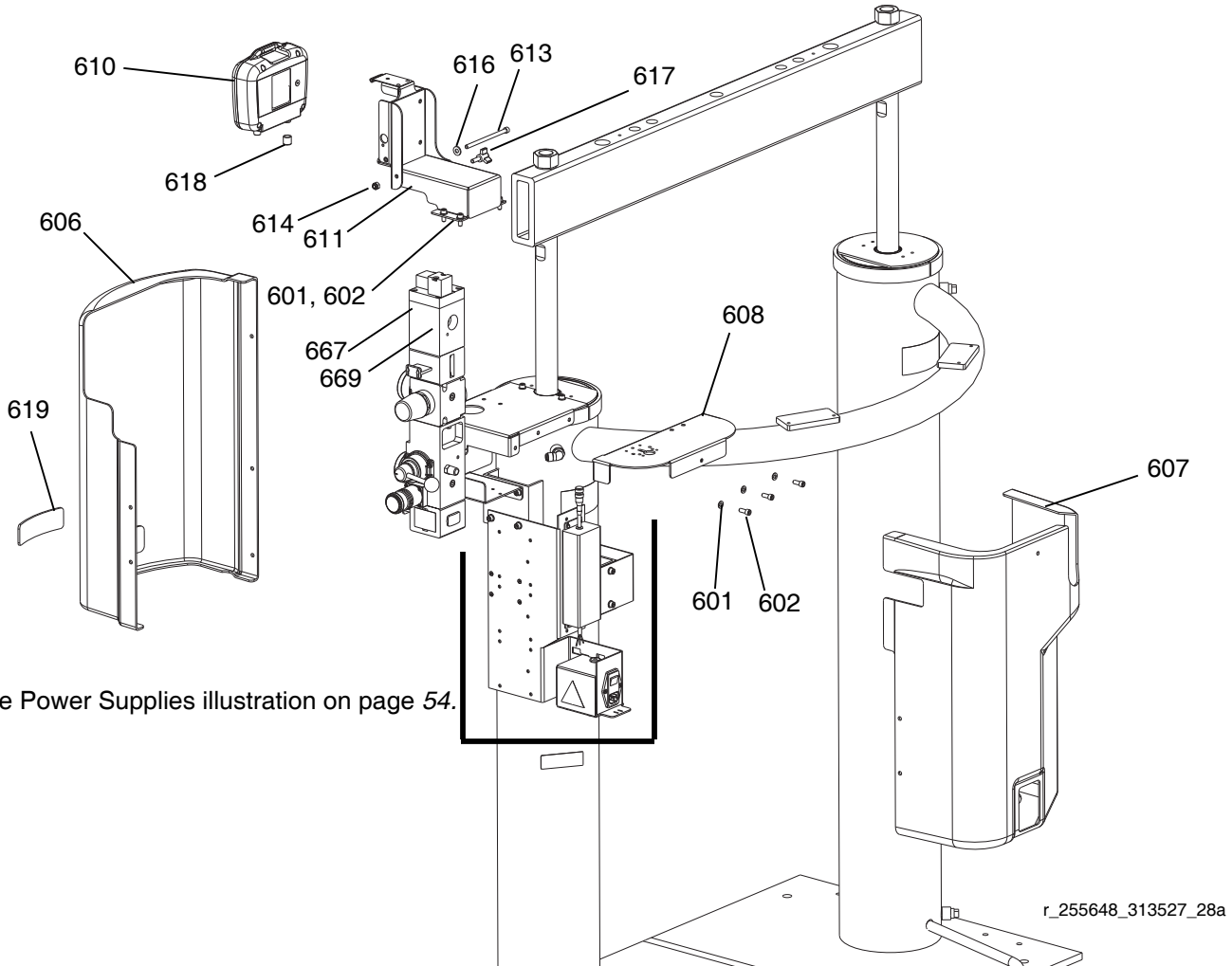
Ref.	Part	Description	Qty.
463	109482	O-RING	1
471		ADAPTER	1
472		SCREW, socket-hd	2
473	109458	O-RING	1

# Accessories

## D200s, D200, and D60 DataTrak Accessory Kits

D200s Supply Units, 255705 (100-240 VAC) and 255758 (24 VDC)

D200 and D60 Supply Units, 255757 (24 VDC) and 255704 (100-240 VAC)



See Power Supplies illustration on page 54.

Ref.	Part	Description	Qty.	Ref.	Part	Description	Qty.
601		WASHER, lock	7	617		KNOB, display adj.	1
602		SCREW, cap, sch	7	618		CAP, vinyl, 0.437 ID x 1/2	1
603		SCREW, captive, slotted	6	619	15R121	LABEL, intelligent pump control	1
604		FASTENER, retainer	6	667▲	189285	LABEL, caution	1
605		CLIP, u-nut	6	669	121235	SOLENOID, air motor, large	1
609		CABLE, CAN, male / female, 0.4m	1	▲ Replacement Danger and Warning labels, tags, and cards are available at no cost.  For D200s, D200, and D60 Supply Units, disassemble fasteners and washers included with ram and use them to attach bracket (611).  See page 63 for varied parts table.			
610	255415	PENDANT, datatrak, ambient ram	1				
611		BRACKET, pendant pivot	1				
612		BRACKET, mounting, assembly	1				
613		SCREW, shcs, 1/4-20UNC x 4.25	1				
614		NUT, lock, hex	1				
615		HARNESS, datatrak, ambient ram	1				
616		WASHER, plain	1				

## Varied Parts for DataTrak Accessory Kits

### D200s, D200, and D60 Supply Units

Ref.	Description	24 VDC		100-240 VAC		Qty.
		D200 D60	D200s	D200 D60	D200s	
		255757	255758	255704	255705	
606	COVER, shroud front	n/a	n/a	n/a	n/a	1
607	COVER, shroud rear	n/a	n/a	n/a	n/a	1
608	BRACKET, light tower	n/a	n/a	n/a	n/a	1
151*	BRACKET, power supply	n/a	n/a	n/a	n/a	1
154a*	POWER SUPPLY, 100-240 VAC			15M293	15M293	1
157a*	SWITCH, power, 100-240 VAC			121254	121254	1
155*	SCREW, machine, pan hd	110637	110637			2
160*	COVER, power			n/a	n/a	1
165*	FUSE, 250V/1.2A			121261	121261	2
154*	MODULE, assembly, 24V	255649	255649			1
160*	COVER, switch mount	n/a	n/a	n/a	n/a	1
163*	CABLE, pwr, female, 0.8M	255673	255673			1
156*	SCREW, self-tapping			101845	101845	6

\* See page 54 for Power Supply illustration.

## Two-Button Interlock Air Control Kit

See 312374 for information.

Supply Unit	Part
D200	255719
D200s	255720
D60	257615

## Drum Roller Kits for D200 and D200S Supply Units, 255627

See 312492 for more information.

## Drum Position Clamp Set for D200 Supply Units, 206537

Includes two clamps.

## Drum Position Clamp for D200S Supply Units

Order quantity 2 of C32463.

## Enclosed Wet Cup Recirc Kit

See 312494 for more information.

## 200 Liter (55 Gallon) Platen Cover Kits, 255691

See 406681 for more information.

## Light Tower Kit, 255467

For D200s, D200, D60, and S20 single supply systems.

See 312493 for more information.

## Check-Mate Displacement Pump Kits

Displacement Pump Size	Manual
60cc	312889
100cc	312467
200cc	312468
250cc	312469
500cc	312470

## Dura-Flo Displacement Pump Kits

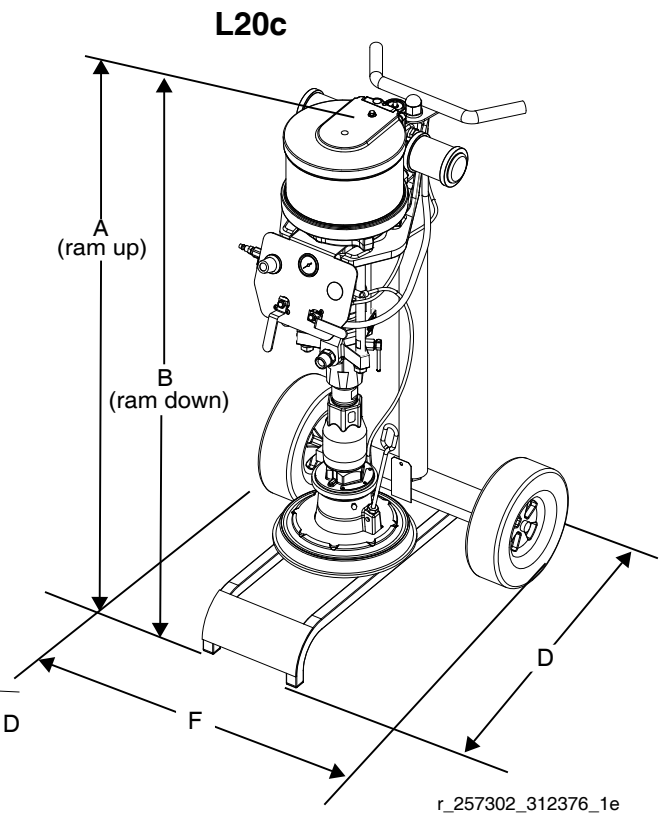
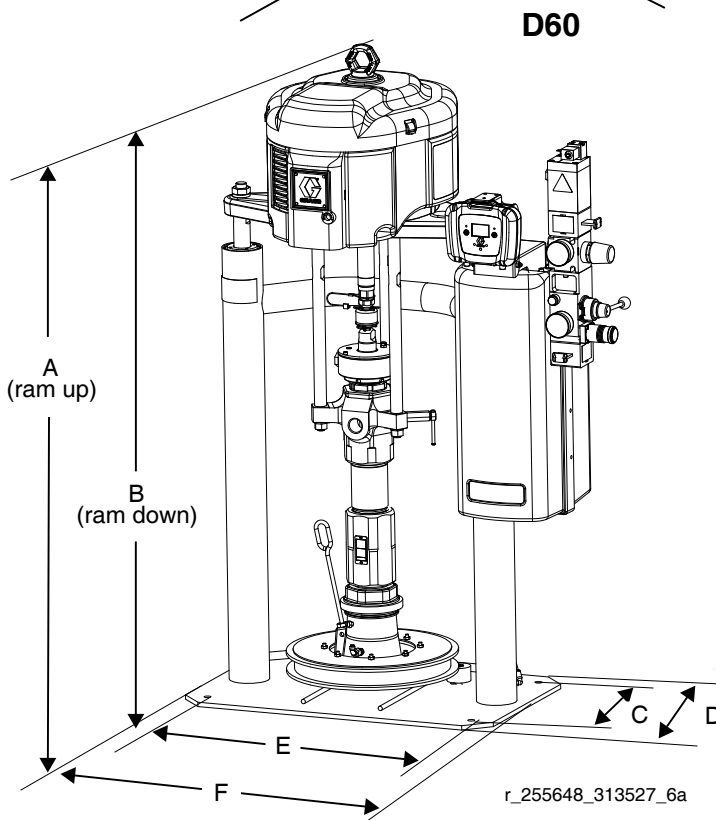
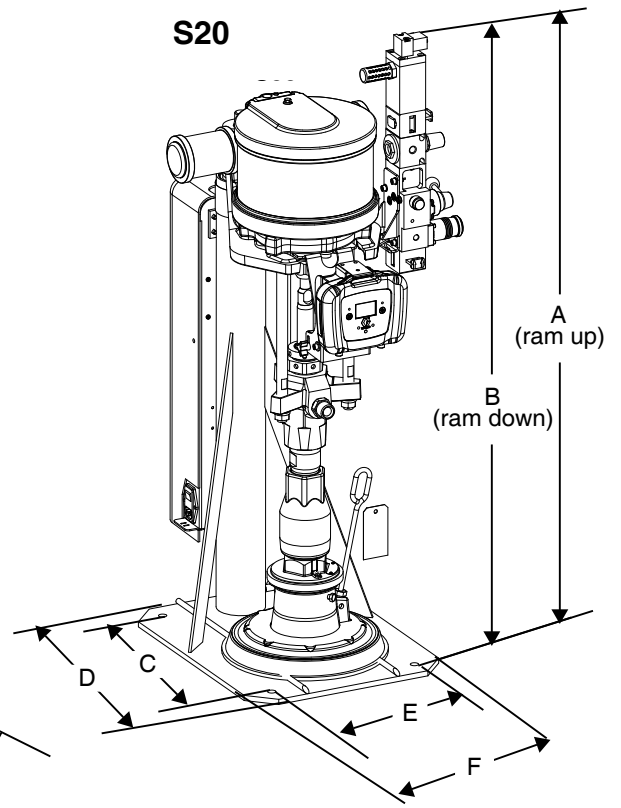
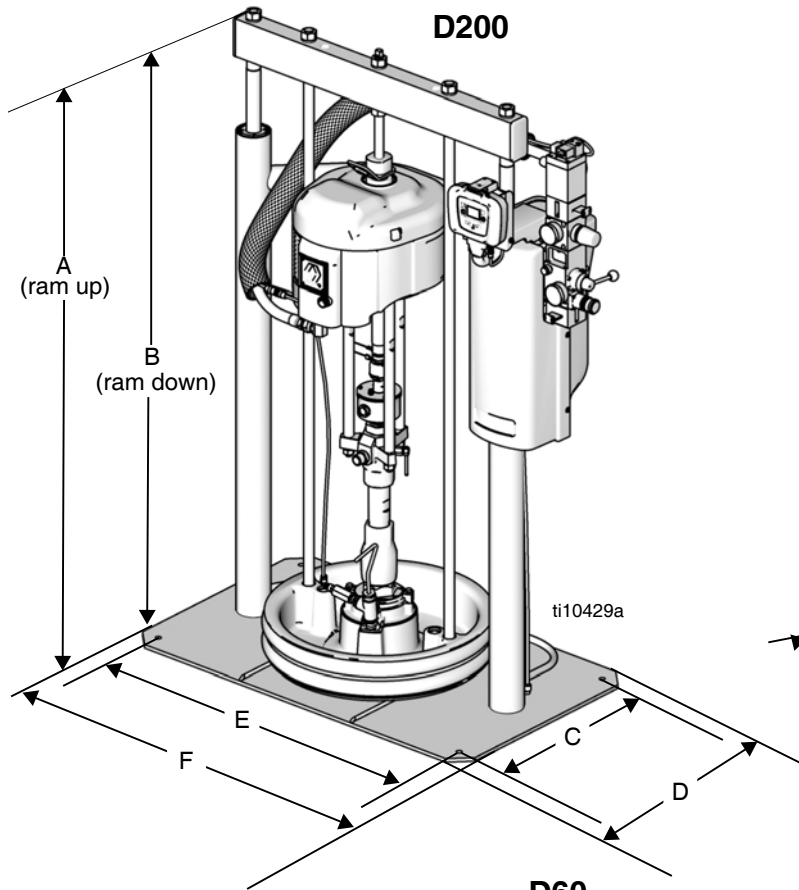
Displacement Pump Size	Manual
145cc, 180cc, 220cc, 290cc	311827
430cc and 580cc	311825
1000cc	311717

## S20 Hose Replacement Kit

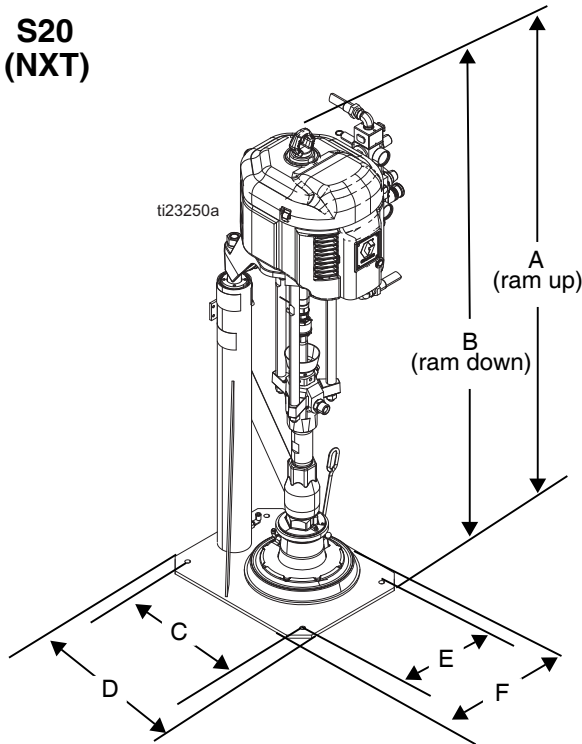
Ref	Part
868	257659



# Dimensions



**S20  
(NXT)**



**Dimensions**

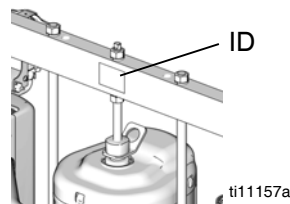
Ram Model	A in. (mm)	B in. (mm)	C in. (mm)	D in. (mm)	E in. (mm)	F in. (mm)
L20c	69 (1752.6)	44 (1117.6)		21 (533.4)		22 (558.8)
<b>S20 (NXT)</b>	84 (2133.6)	59 (1498.6)	16 (406.4)	19 (482.6)	11 (279.4)	15 (381)
S20	59.3 (1506)	35.8 (909)	16 (406.4)	19 (482.6)	11 (279.4)	15 (381)
S20c	90 (2286)	65 (1651)		26.0 (661)		22.1 (562)
D60	89 (2260.6)	59 (1498.6)	14 (355.6)	18 (457.2)	24 (609.6)	28 (711.2)
D200	102.3 (2599)	64.8 (1646)	21.0 (533)	25.0 (635)	38.0 (965)	42.0 (1067)
D200s	104.9 (2665)	70.3 (1785)	23.0 (584)	25.0 (635)	45.0 (1143)	48.0 (1219)

**Weight**

Use the table below to identify the maximum weight for each available platen size.

Platen Size Gallons (Liters)	Maximum Weight
<b>55 (200)</b>	51 (23)
<b>30 (115)</b>	44 (20)
<b>16 (60)</b>	25 (11.3)
<b>8 (30)</b>	21 (9.5)
<b>5 (20)</b>	19 (8.7)

See the identification plate (ID) for the weight of your supply system.



# Technical Specifications

Max air input pressure (supply system) / Air inlet size

L20c - 2 in. elevator, 5 gal. (20 L) . . . . .	100 psi (0.7 MPa, 7 bar) / 1/2 npsm(f)
S20 - 3 in. single post, 5 gal. (20 L) . . . . .	125 psi (0.9 MPa, 9 bar) / 1/2 npt(f)
D60 - 3 in. dual post, 16 gal. (60 L), 5 gal. (20 L), 30 gal. (115 L) . . . . .	150 psi (1.0 MPa, 10 bar) / 3/4 npt(f)
D200 - 3 in. dual post, 55 gal. (200 L), 30 gal. (115 L), 16 gal. (60 L), 8 gal. (30 L), 5 gal. (20 L) . . . . .	150 psi (1.0 MPa, 10 bar) / 3/4 npt(f)
D200s - 6.5 in. dual post, 55 gal. (200 L), 30 gal. (115 L)	125 psi (0.9 MPa, 9 bar) / 3/4 npt(f)

Max fluid, air working pressure, and weight

(displacement pump) . . . . . For Check-Mate pump packages, see manual 312376.  
For Dura-Flo pump packages, see manuals 311826, 311828, 311833.

Wetted parts (displacement pump) . . . . . For Check-Mate displacement pumps, see manual 312375.

For Dura-Flo displacement pumps, see manuals 311717, 311825, 311827.

**Platen Codes** (see page 7): Part number; Wetted parts

**B:** 257727, 5 gal. (20 L) Electroless nickel, polyurethane, nitrile, carbon steel,  
**J:** 257732, 8 gal. (30 L) polyethylene, zinc plated carbon steel, buna, 316 sst,  
**S:** 257737, 16gal. (60 L) . . . . . 17-4PH sst

**C:** 257728, 5 gal. (20 L) Electroless nickel, polyurethane, carbon steel,  
**K:** 257733, 8 gal. (30 L) polyethylene, nitrile, zinc plated carbon steel, buna, 316  
**T:** 257740, 16gal. (60 L) . . . . . sst 17-4PH sst

**F:** 257729, 5 gal. (20 L) Stainless steel, polyurethane, PTFE coated nitrile,  
**L:** 257734, 8 gal. (30 L) polyethylene, nitrile, PTFE, 303 sst, 304 sst, 316 sst,  
**U:** 257738, 16gal. (60 L) . . . . . 17-4PH sst

<b>G:</b> 257730, 5 gal. (20 L)	Electroless nickel, aramind reinforced elastomer, rubber-based PSA, nitrile, polyethylene, zinc plated carbon steel, buna, 1018 carbon steel, 304 sst, 316 sst, 17-4PH sst
<b>M:</b> 257735, 8 gal. (30 L)	
<b>W:</b> 257739, 16gal. (60 L) . . . . .	
<b>H:</b> 257731, 5 gal. (20 L)	Electroless nickel, aramind reinforced elastomer, rubber-based PSA, polyurethane, polyethylene, nitrile, zinc plated carbon steel, buna, 1018 carbon steel, 304 sst, 316 sst, 17-4PH sst
<b>R:</b> 257736, 8 gal. (30 L)	
<b>Y:</b> 257741, 16gal. (60 L) . . . . .	
<b>7:</b> 255661, 30 gal. (115 L) . . . . .	zinc plated carbon steel, EPDM, sst, fluoroelastomer
<b>8:</b> 255662, 55 gal. (200 L) . . . . .	
<b>9:</b> 255663, 55 gal. (200 L) . . . . .	PTFE, EPDM, PTFE coated aluminum, zinc plated carbon steel, 316 sst
<b>A:</b> 255664, 55 gal. (200 L) . . . . .	
<b>D:</b> 24Y343, 55 gal. (200 L) . . . . .	EPDM, aluminum, zinc plated carbon steel, 316 sst
<b>P:</b> 25E110, 5 gal. (20 L) . . . . .	PTFE, neoprene, aluminum, zinc plated carbon steel, 316 sst
<b>25N344</b> , 55 gal. (200 L) . . . . .	EPDM hose, aluminum, zinc plated carbon steel, 316 sst
Ambient operating temperature range (supply system)	Electroless nickel, nitrile, carbon steel, zinc plated carbon steel, buna, 316 sst, 17-4PH sst, aluminum, PVC
Sound data . . . . .	aluminum, zinc plated carbon steel, 316 sst, no seals
External power supply requirements (DataTrak)	32-120 °F (0- 49°C)
AC power units . . . . .	See separate air motor manual.
DC power units . . . . .	100-240 VAC, 50/60 Hz, single phase, 1.2 amps max draw
	24 VDC, 1.2 amps max draw

## California Proposition 65

### CALIFORNIA RESIDENTS

 **WARNING:** Cancer and reproductive harm – [www.P65warnings.ca.gov](http://www.P65warnings.ca.gov).



# Graco Standard Warranty

Graco warrants all equipment referenced in this document which is manufactured by Graco and bearing its name to be free from defects in material and workmanship on the date of sale to the original purchaser for use. With the exception of any special, extended, or limited warranty published by Graco, Graco will, for a period of twelve months from the date of sale, repair or replace any part of the equipment determined by Graco to be defective. This warranty applies only when the equipment is installed, operated and maintained in accordance with Graco's written recommendations.

This warranty does not cover, and Graco shall not be liable for general wear and tear, or any malfunction, damage or wear caused by faulty installation, misapplication, abrasion, corrosion, inadequate or improper maintenance, negligence, accident, tampering, or substitution of non-Graco component parts. Nor shall Graco be liable for malfunction, damage or wear caused by the incompatibility of Graco equipment with structures, accessories, equipment or materials not supplied by Graco, or the improper design, manufacture, installation, operation or maintenance of structures, accessories, equipment or materials not supplied by Graco.

This warranty is conditioned upon the prepaid return of the equipment claimed to be defective to an authorized Graco distributor for verification of the claimed defect. If the claimed defect is verified, Graco will repair or replace free of charge any defective parts. The equipment will be returned to the original purchaser transportation prepaid. If inspection of the equipment does not disclose any defect in material or workmanship, repairs will be made at a reasonable charge, which charges may include the costs of parts, labor, and transportation.

**THIS WARRANTY IS EXCLUSIVE, AND IS IN LIEU OF ANY OTHER WARRANTIES, EXPRESS OR IMPLIED, INCLUDING BUT NOT LIMITED TO WARRANTY OF MERCHANTABILITY OR WARRANTY OF FITNESS FOR A PARTICULAR PURPOSE.**

Graco's sole obligation and buyer's sole remedy for any breach of warranty shall be as set forth above. The buyer agrees that no other remedy (including, but not limited to, incidental or consequential damages for lost profits, lost sales, injury to person or property, or any other incidental or consequential loss) shall be available. Any action for breach of warranty must be brought within two (2) years of the date of sale.

**GRACO MAKES NO WARRANTY, AND DISCLAIMS ALL IMPLIED WARRANTIES OF MERCHANTABILITY AND FITNESS FOR A PARTICULAR PURPOSE, IN CONNECTION WITH ACCESSORIES, EQUIPMENT, MATERIALS OR COMPONENTS SOLD BUT NOT MANUFACTURED BY GRACO.** These items sold, but not manufactured by Graco (such as electric motors, switches, hose, etc.), are subject to the warranty, if any, of their manufacturer. Graco will provide purchaser with reasonable assistance in making any claim for breach of these warranties.

In no event will Graco be liable for indirect, incidental, special or consequential damages resulting from Graco supplying equipment hereunder, or the furnishing, performance, or use of any products or other goods sold hereto, whether due to a breach of contract, breach of warranty, the negligence of Graco, or otherwise.

## **FOR GRACO CANADA CUSTOMERS**

The Parties acknowledge that they have required that the present document, as well as all documents, notices and legal proceedings entered into, given or instituted pursuant hereto or relating directly or indirectly hereto, be drawn up in English. Les parties reconnaissent avoir convenu que la rédaction du présente document sera en Anglais, ainsi que tous documents, avis et procédures judiciaires exécutés, donnés ou intentés, à la suite de ou en rapport, directement ou indirectement, avec les procédures concernées.

## Graco Information

For the latest information about Graco products, visit [www.graco.com](http://www.graco.com).

For patent information, see [www.graco.com/patents](http://www.graco.com/patents).

**TO PLACE AN ORDER, contact your Graco distributor or call to identify the nearest distributor.**

**Phone: 612-623-6921 or Toll Free: 1-800-328-0211 Fax: 612-378-3505**

*All written and visual data contained in this document reflects the latest product information available at the time of publication. Graco reserves the right to make changes at any time without notice.*

Original instructions. This manual contains English. MM 313527

**Graco Headquarters:** Minneapolis

**International Offices:** Belgium, China, Japan, Korea

**GRACO INC. AND SUBSIDIARIES • P.O. BOX 1441 • MINNEAPOLIS MN 55440-1441 • USA**

Copyright 2020, Graco Inc. All Graco manufacturing locations are registered to ISO 9001.

[www.graco.com](http://www.graco.com)

Revision ZAK, October 2020