

**MANNESMANN
REXROTH****External gear pumps
Type G2, Series 4X****RE
10 030/04.99**

NS 4 to 22

up to 250 bar

up to 22.4 cm³

Replaces: 05.98

- New principle of housing sealing, thereby giving a very long housing service life
- Long seal service life also at maximum temperatures
- Plain bearings for high loads
- Mono-block bearing
- Simple and robust design
- New principle of hydrostatic gap compensation
- Common suction port for double pump, on request
- Mono block intermediate flange

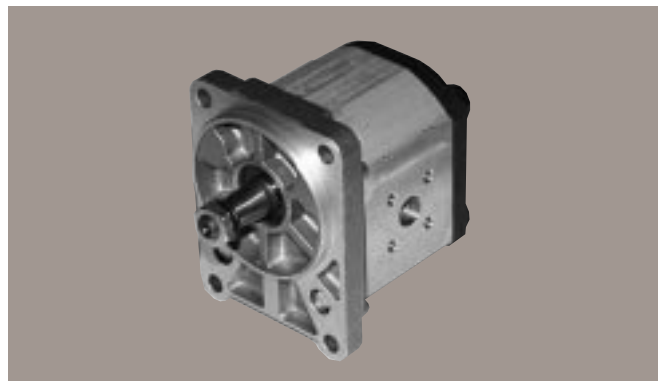

1 PF 2 G2-4X/011 RC 20 MB

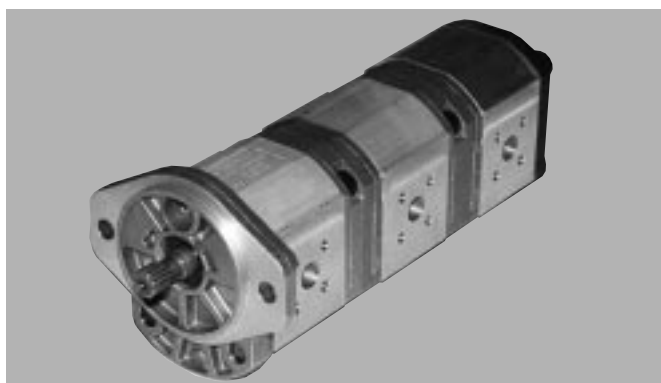

1 PFG2-4X/011 RR 20 MRK+
1 PFG2-4X/011 LN 20 MDN+
1 PFG2-4X/008 LN 20 MDL



Special version (S107) with a common suction port, on request

Type G2 hydraulic pumps are self-priming external gear pumps. Their task is to produce a constant flow and at the same time pass on the required forces.

They mainly consist of the housing (1), mounting flange (2), drive shaft (3), 2 bearing blocks (4), bearing bush (5) and discs (6) for the hydrostatic gap compensation.

The gears separating during the rotational movement releases the gear chambers. The negative pressure resulting from this, as well as the atmospheric pressure acting on the pressure fluid level in the tank causes the pressure fluid to flow to the pump

from the tank. This pressure fluid fills the gear chambers and is moved, in the direction of the arrow (see sectional drawing), from the the suction to the pressure side.

Here the gears mesh once more and push the pressure fluid out of the gear chambers and prevent return flow to the suction chamber.

In order to avoid hard and jolting running of the pump, small unloading grooves are cut into the sides of the bearing blocks (4). The "compressed fluid" is thereby passed into the pressure chamber.

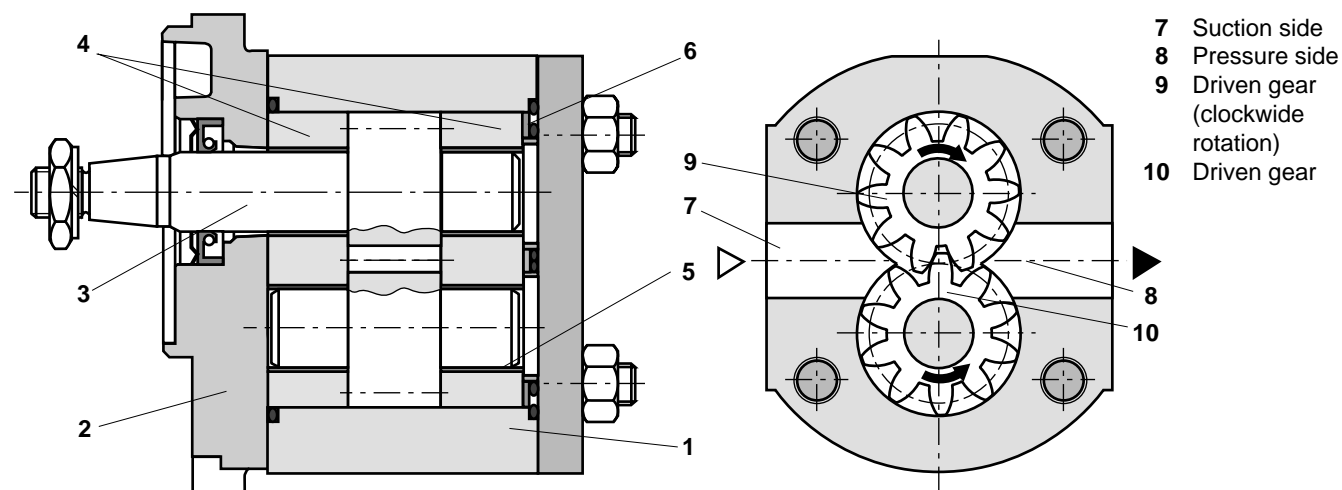

- 7 Suction side
- 8 Pressure side
- 9 Driven gear (clockwise rotation)
- 10 Driven gear

Ordering details

1 PF 2 G2 - 4X /

*

Series 40 to 49
(40 to 49: unchanged installation
and connection dimensions)

= 4X

Further details
in clear text

(Nominal flow)	NS		
4 cm ³	4	=	004
5.5 cm ³	5	=	005
8.2 cm ³	8	=	008
11 cm ³	11	=	011
14.1 cm ³	14	=	014 ¹⁾
16.2 cm ³	16	=	016
19 cm ³	19	=	019 ¹⁾
22.4 cm ³	22	=	022

Clockwise rotation = R
Anti-clockwise rotation = L

Tapered shaft 1:5 Ø 17 mm = C
Splined shaft SAE-A 5/8", 9 teeth = R
Tongued shaft with coupling for single pump,
centre/rear pump = N
Tapered shaft 1:5 Ø 20 mm for front bearing = S
Cylindrical shaft ISO Ø 18 (with 01 ports) = A
Tapered shaft 1:8 Ø 17.4 mm = H

No code =

Single pump

K = Front pump for combination

L = Rear pump for combination

N = Centre pump for combination

B = Rectangular flange Ø 80 mm

P = 2-hole fixing Ø 50 mm

R = SAE-A-2-hole flange Ø 82.5 mm

M = 2-hole fixing Ø 52 mm

O = Rectangular flange Ø 36.5 mm

A = Front bearing Ø 80 mm

D = Combination flange for G2
(rear and centre pump)

H = Combination flange for G3, G4

M = NBR seals up to 80 °C

K = FKM shaft seal ring

other seals NBR

(connection to diesel engines)

20 = Suction and pressure port square
flange, metric mounting threads

01 = Pipe thread to ISO 228/1
(with cylindrical shaft A)

30 = Suction and pressure port square flange,
metric mounting threads at the vertical and
horizontal connection axis (Italian version)

Ordering examples for single pumps:

1PF2G2-4X/005RC20MB Material no. 363013

1PF2G2-4X/016RC20MBK Material no. 363115

(only front pump)

1PF2G2-4X/008LN20MDL Material no. 363126

(only rear pump)

Ordering example for multiple pumps

1PF2G2-4X/008RC20MBK Material no. 363109

1PF2G2-4X/004LN20MDL Material no. 363122

Combination parts G2/008 + G2/004

Multiple pumps are supplied completely assembled. The combination parts, however, have to be listed as separate items within an order (see ordering example).

The material no. of the combination parts is entered during order processing.

It is possible to order the combination parts as a kit on their own. For the ordering code see the multiple pumps example. The kit consists of 2 tie rods and 2 nuts. The coupling is included within the scope of supply of the rear or centre pump.

1PF2G2-4X/022RC20MBK Material no. 363119

1PF2G2-4X/011LN20MDN Material no. 363296

1PF2G2-4X/005LN20MDL Material no. 363124

Combination parts G2/022 + G2/011 + G2/005

Note: Only pump types which are listed in the catalogue sheets and have material numbers are available.

Other types on request.

Flange fittings for pipe connections (see page 12) and pump mounting brackets to catalogue sheet RE 32 110 for rectangular flanges version "B" have to be ordered separately.

Symbols

Single pump

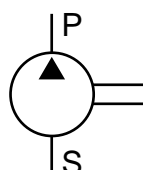

Double pump

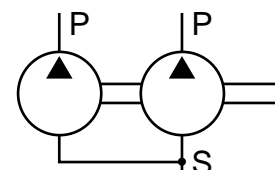
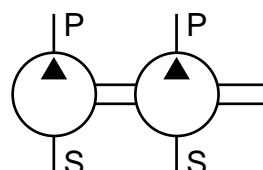

On request

Technical data (for applications outside these parameters, please consult us!)**Pressure fluid:** Mineral oil to catalogue sheet RE 07 075.

For operation with HFC-, HFD-, HETG-, HEPG- and HEES- fluids see RE 10 025-S.

Pressure fluid temperature range: – 15 to + 80 °C.

For higher temperatures please consult us

Ambient temperature range: – 15 to + 60 °C**Viscosity range:**10 bis 300 mm²/s (recommended viscosity)1000 mm²/s (permissible start-up viscosity)**Maximum permissible degree of contamination** of the pressure fluid is to NAS 1638, class 10. We, therefore, recommend a filter with a minimum retention rate of $\beta_{20} \geq 100$. To ensure a long service life we recommend class 9, NAS 1638; achievable with a filter retention rate of $\beta_{10} \geq 100$.**Drive type:** elastic coupling, for other drive types please consult us**Installation:** optional**Direction of rotation:** the pump may only be driven in the given direction of rotation**Weight:** see table for individual pump types

Nominal size		4	5	8	11	14	16	19	22
Nominal flow	cm ³	4	5.5	8.2	11	14.1	16.2	19	22.4
Operating pressure, inlet: absolute pressure	bar	$p_{abs\ min} 0.7$ $p_{abs\ max} 3.0$							
Max. continuous pressure p_1	bar	250	250	250	250	250	250	240	210
Max. peak pressure p_2 (10 ⁶ peaks)	bar	275	275	275	275	275	275	270	230
Max. speed at continuous pressure p_1	min ⁻¹	5000	4000	4000	4000	3500	3000	3000	2500
Min. speed at $p = 180$ bar	min ⁻¹	1000	1000	700	500	500	500	500	500
Min. speed at p_1	min ⁻¹	1200	1200	1000	700	700	700	700	700

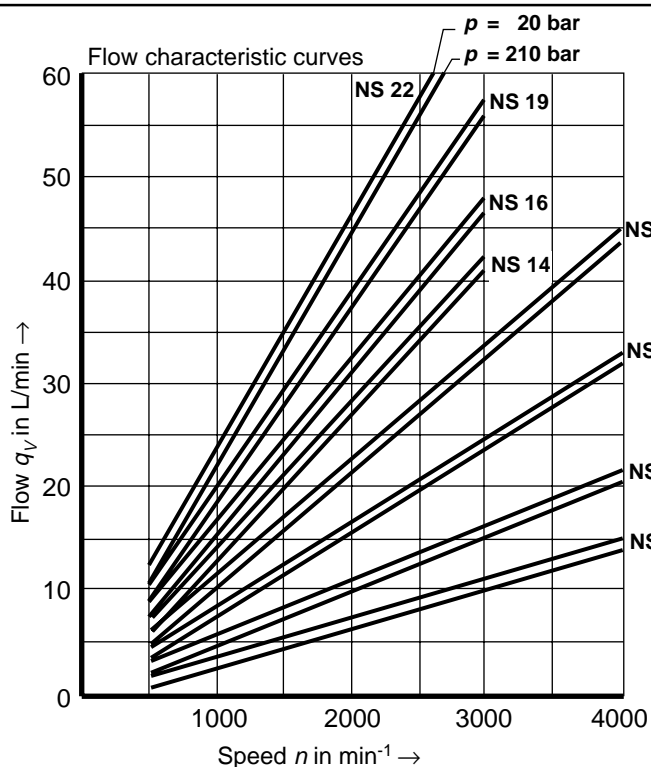
Characteristic curves (measured at $\nu = 41$ mm²/s and $\vartheta = 50$ °C)

- A = Cylindrical shaft \varnothing 18 mm $T_{max} = 70$ Nm
 C = Tapered shaft 1 : 5 \varnothing 17 mm $T_{max} = 150$ Nm
 R = Splined shaft SAE-A5/8" $T_{max} = 110$ Nm
 N = Shaft with tongued coupling $T_{max} = 70$ Nm
 S = Tapered shaft 1 : 5 \varnothing 20 mm $T_{max} = 70$ Nm
 H = Tapered shaft 1 : 8 \varnothing 17,4 mm $T_{max} = 150$ Nm

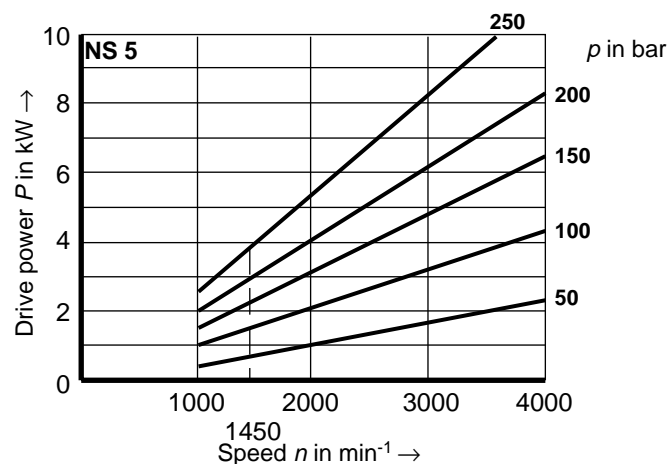
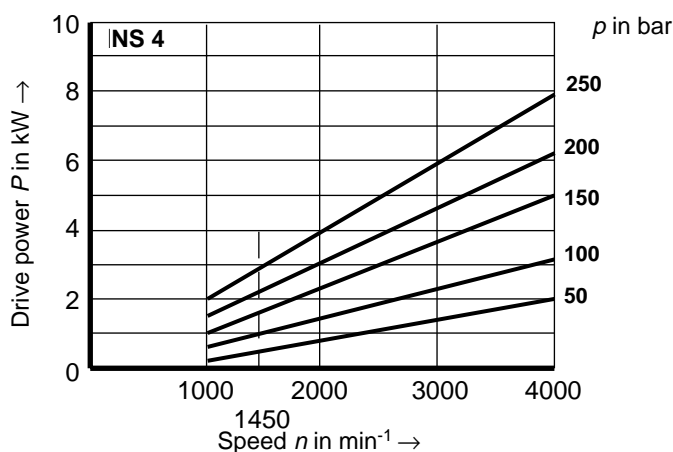
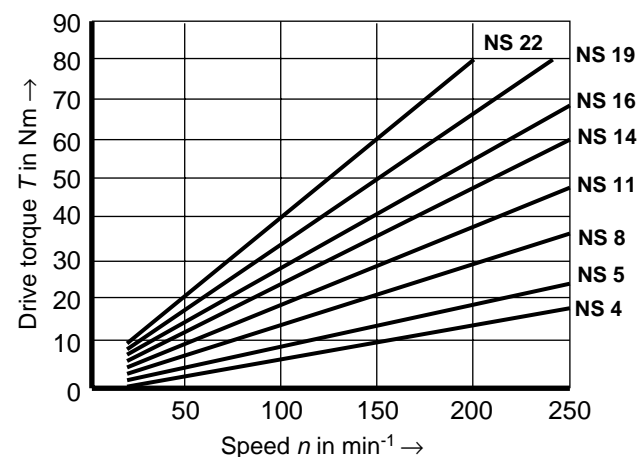

Characteristic curves (measured at $v = 41 \text{ mm}^2/\text{s}$ and $\vartheta = 50^\circ\text{C}$)

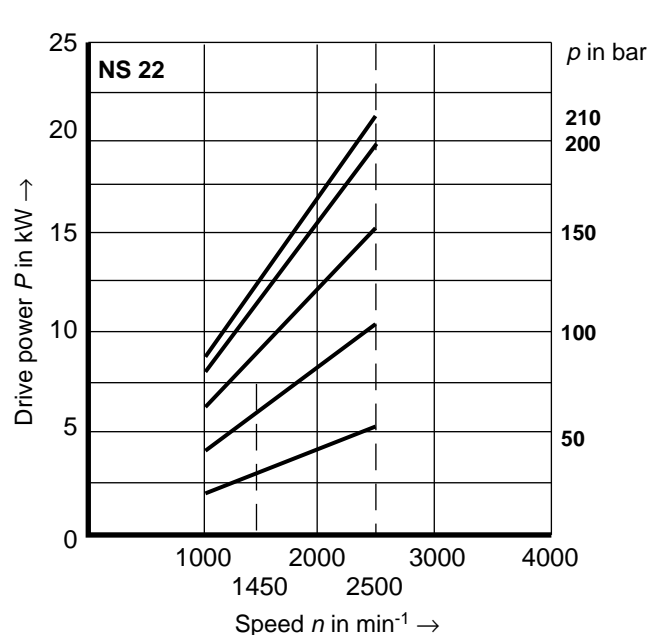
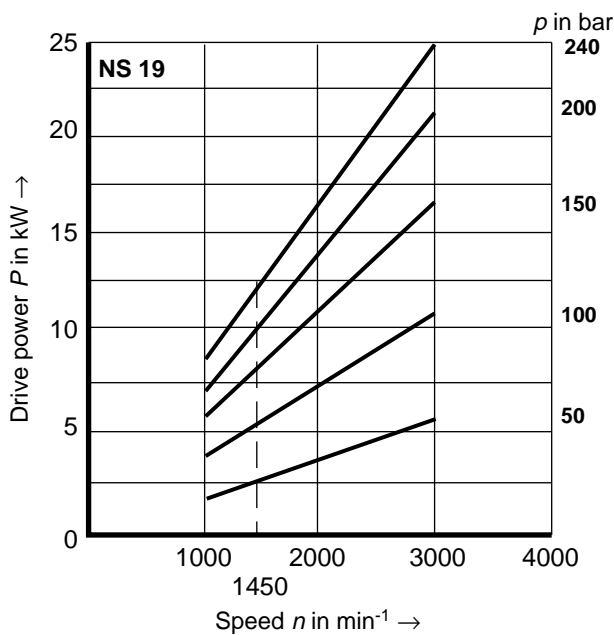
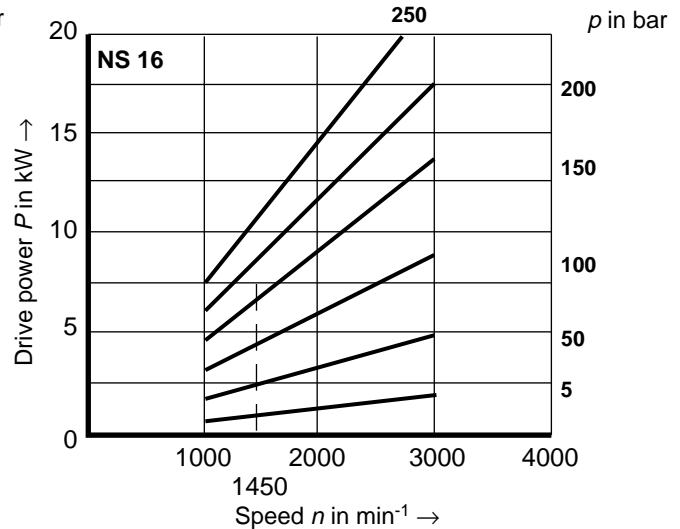
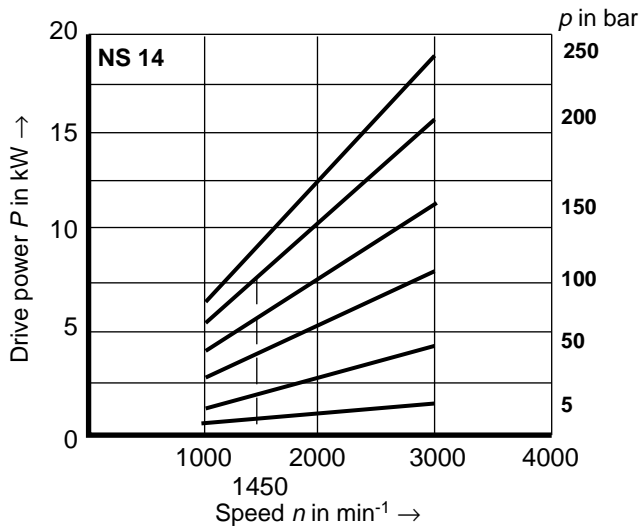
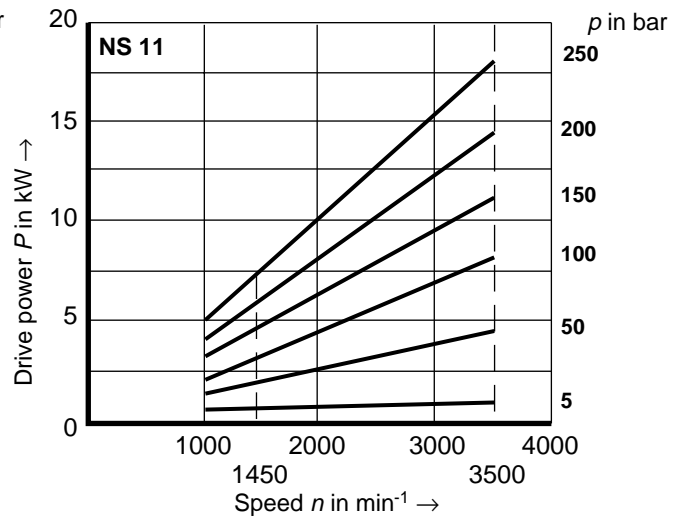
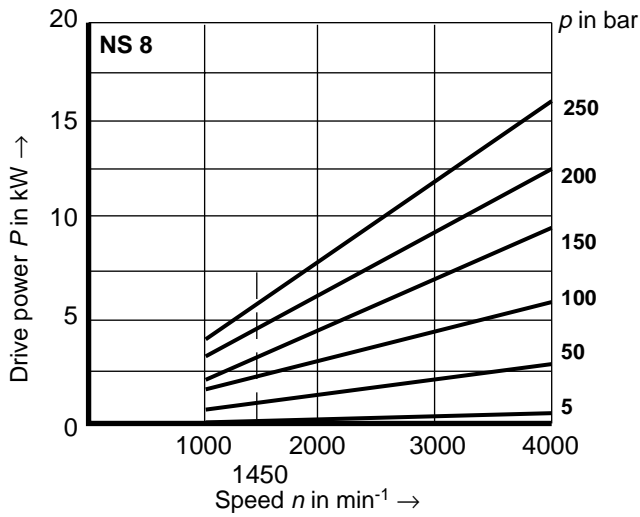

Noise pressure level (measured at $v = 1450 \text{ min}^{-1}$, $n = 41 \text{ mm}^2/\text{s}$ and $\vartheta = 50 \text{ }^\circ\text{C}$)

ρ in bar \ NS	4	5	8	11	14	16	19	22
5	57	59	59	59	62	62	62.5	62
50	58.5	60	60	60	64	66.5	67	66
100	59	61	61	62	65.5	68	69.5	67
150	60	62	62	64.5	66.5	69	70.5	68.5
200	61	63	63.5	66	68	69.5	70	69
250	61.5	64.5	65	68	69.5	70.5	71	-

Measured in an anechoic chamber to DIN 45 635 part 26 in dB(A)
Distance microphone – pump = 1 m

Shaft end

(Dimensions in mm)

C

Tapered shaft 1 : 5, $\varnothing 17 \text{ mm}$

Tightening torque:
 70^{+10}_0 Nm

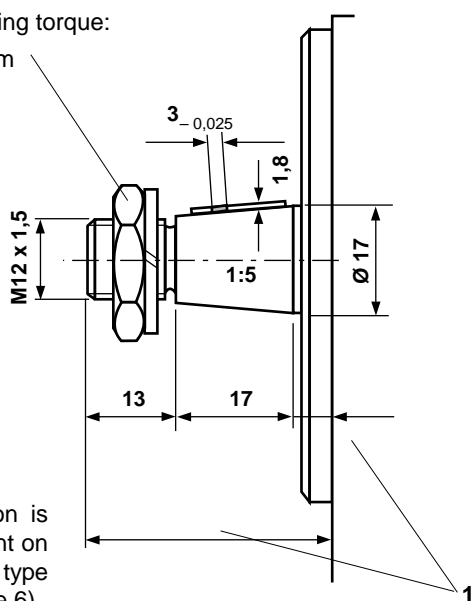

R

Splined shaft SAE-A 5/8", 9T, 16/32 D/P and tooth thickness $t = 2,357_{-0,030}$

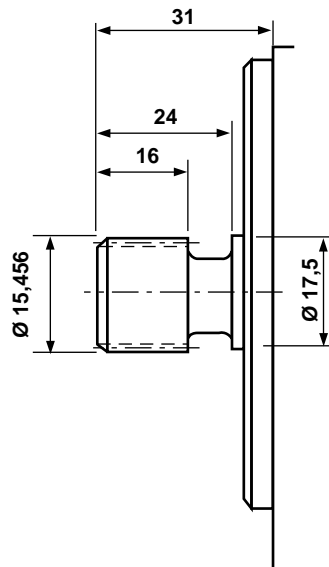

S

Tapered shaft 1 : 5, $\varnothing 20 \text{ mm}$ for front bearing

Tightening torque:
 70^{+10}_0 Nm

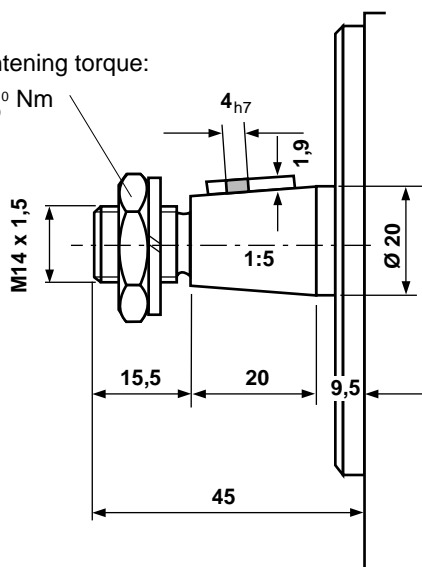

N

Tongued shaft with coupling for single pump, centre/rear pump

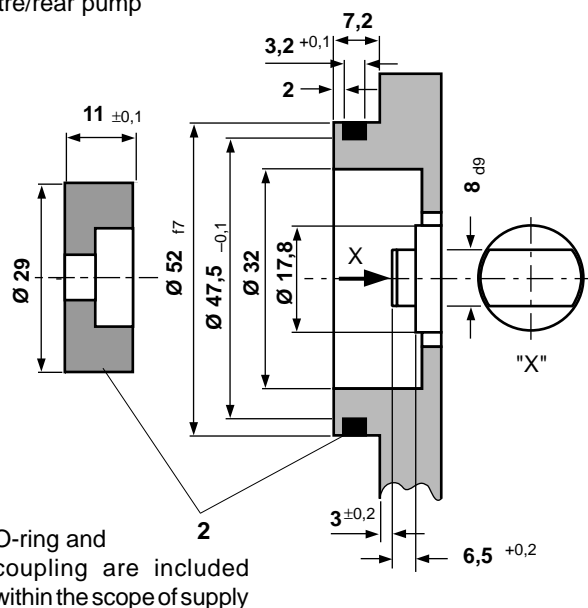

Shaft end

(Dimensions in mm)

A

Cylindrical shaft ISO \varnothing 18 mm

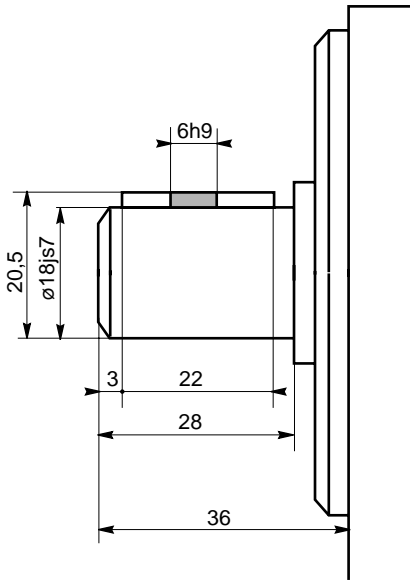

H

Tapered shaft 1 : 8, \varnothing 17,4 mm

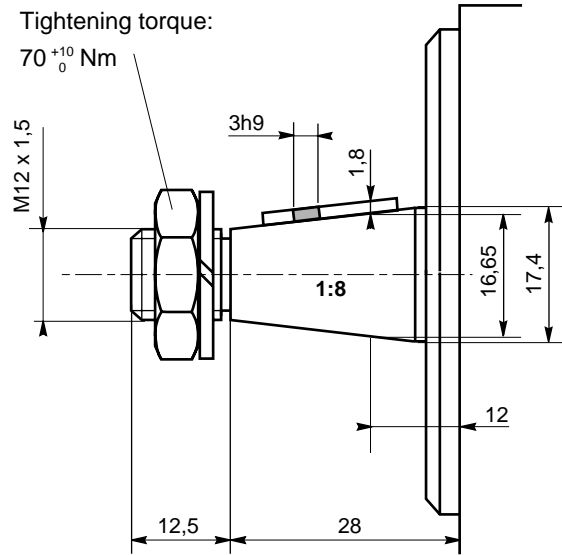

Unit dimensions, ordering details: (dimensions in mm, A = preferred types)

1 PF 2 G2-4X/... R A 01 MB

Nominal size (see table)

Direction of rotation:

Clockwise
anti-clockwise

= R
= L

Cylindrical shaft
 \varnothing 18 mm

Nominal size	Dimensions				Material no.		Weight in kg
	L	B	D1	D2	Clockwise	Anti-clockwise	
004	88	42.25	G 1/2	34	530566A	530567	2.7
005	93	41.5	G 1/2	34	530568A	530569	2.7
008	93	45.25	G 1/2	34	530570A	530571	2.8
011	98	47.25	G 3/4	42	530572A	530573	3.0
016	108	49	G 3/4	42	530574A	530575	3.0
022	113	55.5	G 3/4	42	530576A	530577	3.5

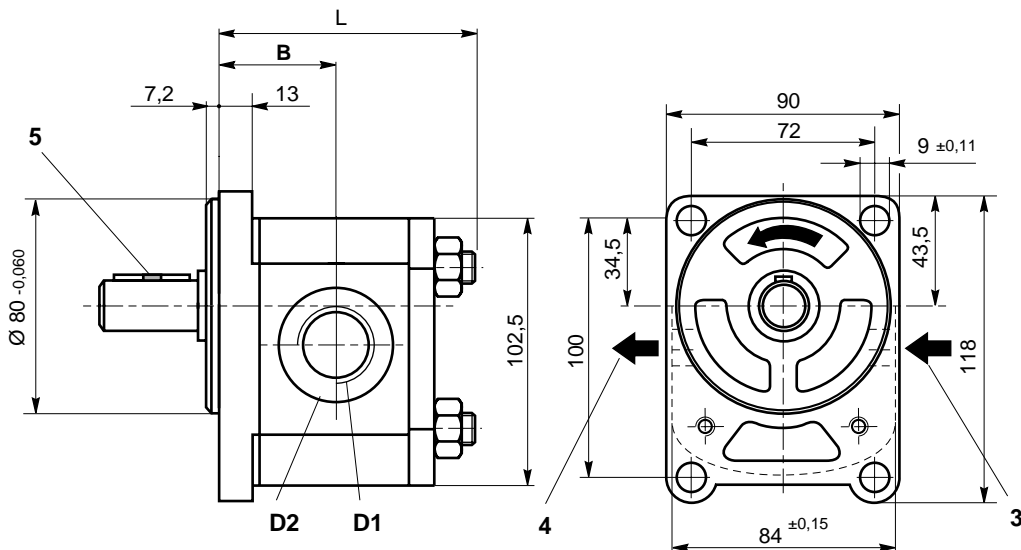

Direction of rotation: anti-clockwise (version "L") viewed on the shaft end
With clockwise rotation version "R" the suction and pressure ports are exchanged!

3 Suction side **5** Cylindrical shaft
4 Pressure side \varnothing 18 mm

Unit dimensions, ordering details: (dimensions in mm, A = preferred types)

1 PF 2 G2-4X/... R C 20 MB

Nom. size (see table)

Direction of rotation:

Clockwise = R

Anti-clockwise = L

Tapered shaft
1 : 5; Ø 17 mm

Nom. size	Dimensions		Material no.		Weight in kg
	L	B	Clockwise	Anti-clockwise	
004	88	42.25	00363011 A	00363012	2.4
005	93	41.5	00363013 A	00363014	2.5
008	93	45.25	00363015 A	00363016	2.6
011	98	47.25	00363017 A	00363018	2.7
014	103	49.5	00363019	00363020	2.8
016	108	49	00363021 A	00363022	2.9
019	108	51	00363023 A	00363024	3.1
022	119	55.5	00363025 A	00363026	3.3

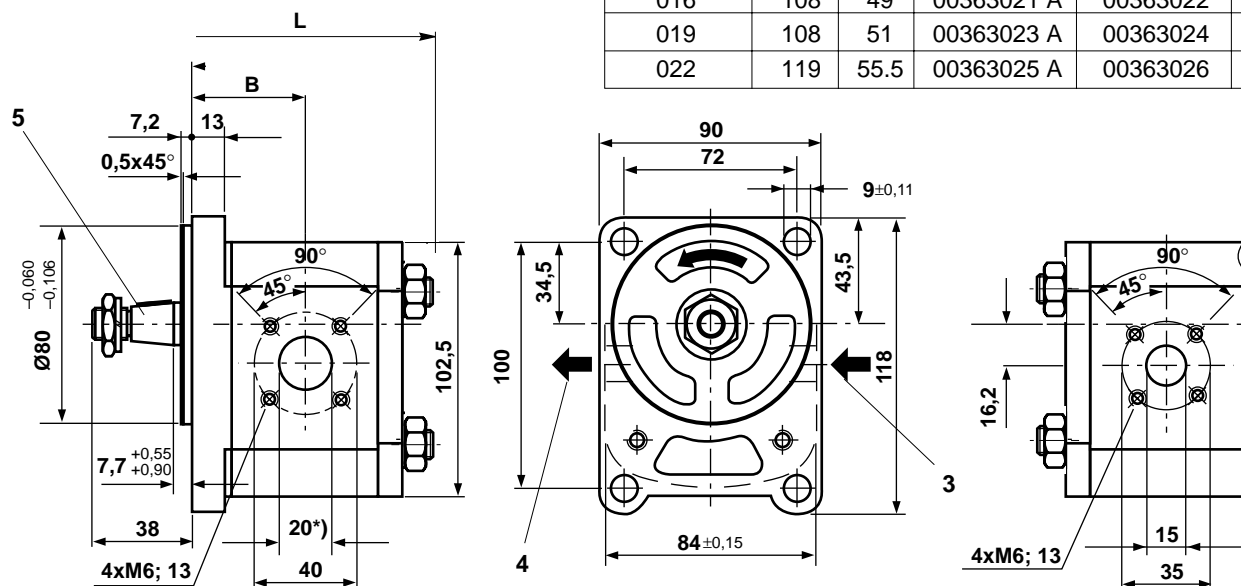

*) Ø15 with NS 4 and 5

Direction of rotation: anti-clockwise (version "L") viewed on the shaft end
With clockwise rotation version "R" the suction and pressure ports are exchanged!

3 Suction side 5 Tapered shaft
4 Pressure side 1 : 5; Ø 17 mm
(see page 5)

1 PF 2 G2-4X/... R C 20 KP

Nom. size (see table)

Direction of rotation:

Clockwise = R

Anti-clockwise = L

Tapered shaft
1 : 5; Ø 17 mm

Nom. size	Dimensions		Material no.		Weight in kg
	L	B	Clockwise	Anti-clockwise	
004	85.5	39.75	00363027	00363028	2.7
005	90.5	39	00363029	00363030	2.7
008	90.5	42.75	00363031	00363032	2.8
011	95.5	45	00363033	00363034	3.0
014	100.5	47	On request		3.0
016	105.5	46.5	00363037	00363038	3.0
019	105.5	48.5	00363039	00363040	3.2
022	110.5	53	00363041	00363042	3.5

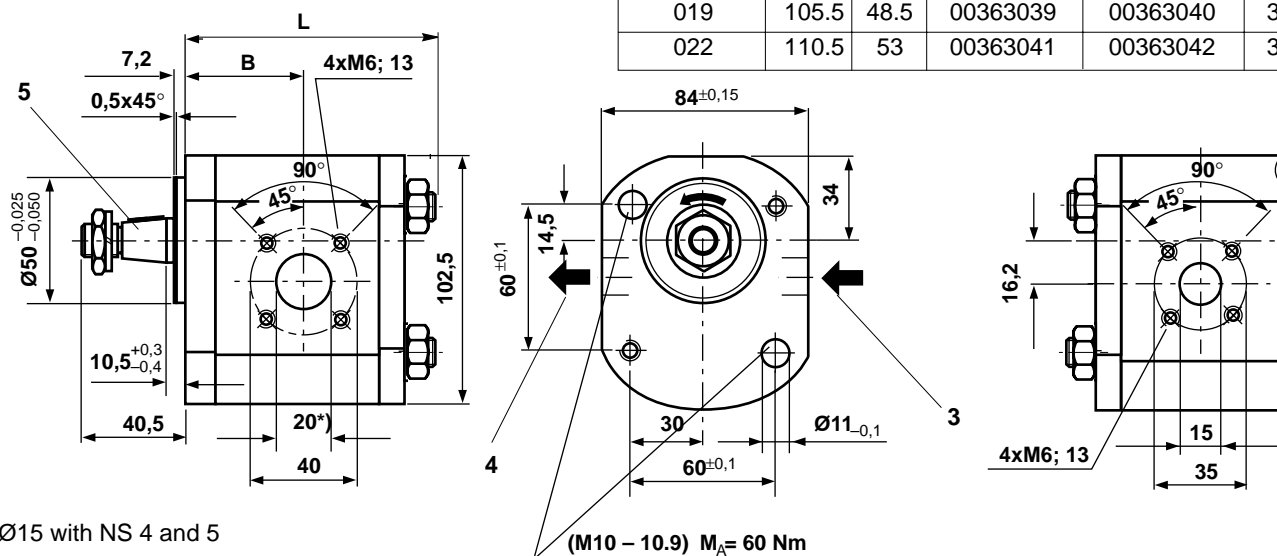

*) Ø15 with NS 4 and 5

Direction of rotation: anti-clockwise (version "L") viewed on the shaft end
With clockwise rotation version "R" the suction and pressure ports are exchanged!

3 Suction side 5 Tapered shaft
4 Pressure side 1 : 5; Ø 17 mm
(see page 5)

Unit dimensions, ordering details: (dimensions in mm, A = preferred types)

1 PF 2 G2-4X/... R R 20 MR
L

Nom. size (see table)

Direction of rotation:

Clockwise = R

Anti-clockwise = L

Splined shaft
SAE-A5/8"
9teeth

Nom. size	Dimensions		Material no.		Weight in kg
	L	B	Clockwise	Anti-clockwise	
004	88.5	42.75	00363043 A	00363044	2.6
005	93.5	42	00363045	00363046	2.6
008	93.5	45.75	00363047 A	00363048	2.8
011	98.5	47.75	00363049 A	00363050	2.9
014	103.5	50	00363051	00363052	3.0
016	108.5	49.5	00363053 A	00363054	3.1
019	108.5	51.5	00363055 A	00363056	3.2
022	118.5	56	00363057 A	00363058	3.3

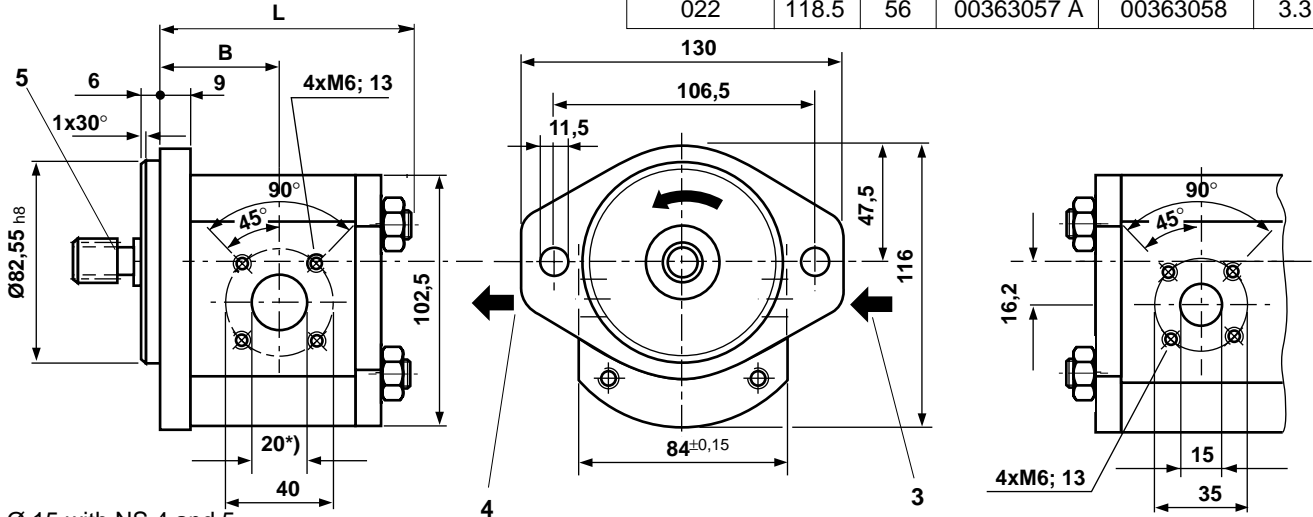

*) Ø 15 with NS 4 and 5

Direction of rotation: Anti-clockwise (version "L") viewed on the shaft
With clockwise rotation version "R" the suction and pressure ports are exchanged!

3 Suction side
4 Pressure side

5 Splined shaft
(see page 5)

1 PF 2 G2-4X/... R N 20 MM
L

Nom. size (see table)

Direction of rotation:

Clockwise = R

Anti-clockwise = L

Shaft
with tongued coupling

Nom. size	Dimensions		Material no.		Weight in kg
	L	B	Clockwise	Anti-clockwise	
004	85.5	39.75	00363059	00363060	2.6
005	90.5	39	00363061	00363062	2.6
008	90.5	42.75	00363063	00363064	2.7
011	95.5	45	00363065	00363066	3.0
014	100.5	47	On request		3.0
016	105.5	46.5	00363069	00363070	3.0
019	105.5	48.5	00363071	00363072	3.0
022	110.5	53	00363073	00363074	3.5

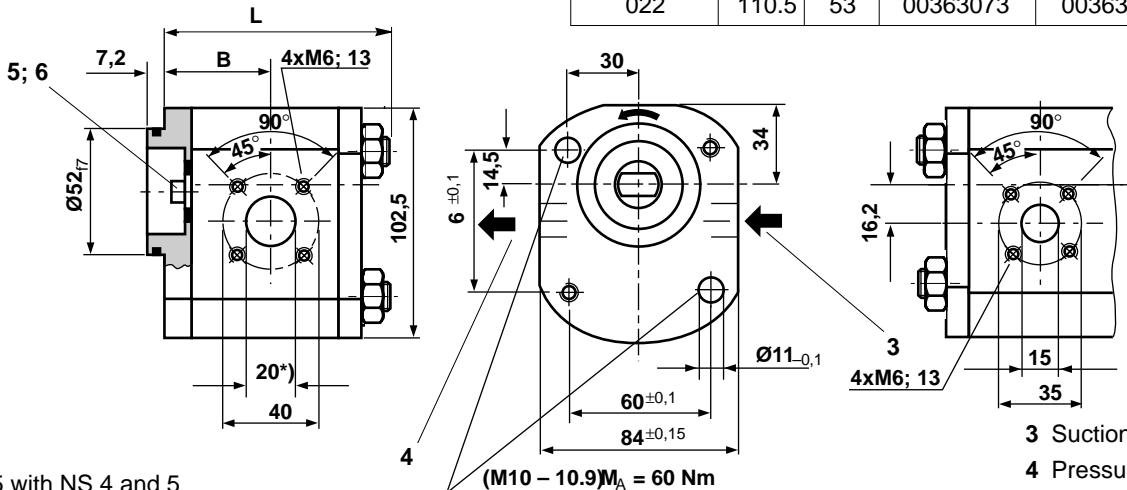

*) Ø 15 with NS 4 and 5

Direction of rotation: Anti-clockwise (version "L") viewed on the shaft
With clockwise rotation version "R" the suction and pressure ports are exchanged!

Attention: With NS 19 and 22 pressure limitation due to maximum permissible torque (see page 3).

3 Suction side
4 Pressure side

5 Tongued shaft with
coupling (see page 5)
6 Pump without shaft
seal ring

Unit dimensions, ordering details

(Dimensions in mm)

1 PF 2 G2-4X/... R S 20 MA

Nom. size (see table)

Direction of rotation:

Clockwise

= R

Anti-clockwise

= L

Tapered shaft
1 : 5; Ø 20 mm

Pump with front bearing
to take up radial
and axial forces
(see below)

Nom. size	Dimensions		Material no.		Weight in kg
	L	B	Clockwise	Anti-clockwise	
004	117.5	71.5	00363075	00363076	3.4
005	122.5	71	00363077	00363078	3.4
008	122.5	74.75	00363079	00363080	3.5
011	127.5	77	00363081	00363082	3.8
014	132.5	79	On request		3.8
016	137.5	78.5	00363085	00363086	3.8
019	142.5	80.5	00363087	00363088	3.8
022	147.5	85	00363089	00363090	4.3

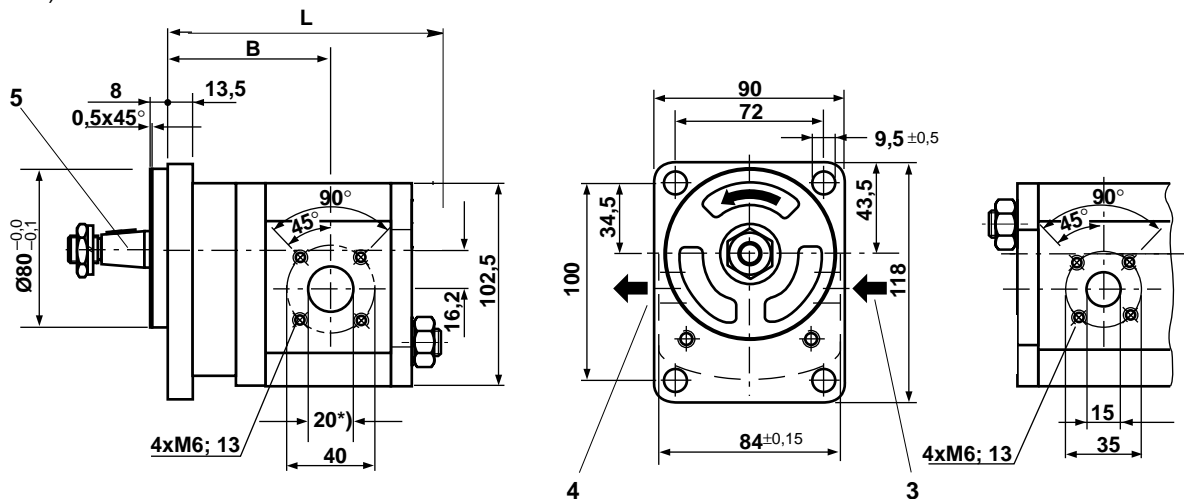

*) Ø 15 with NS 4 and 5

Direction of rotation: Anti-clockwise (version "L") viewed on the shaft end with clockwise rotation version "R" the suction and pressure ports are exchanged!
Attention: With NS 19 and 22 pressure limitation due to maximum permissible torque at the front bearing (see page 3).

- 3 Suction side
- 4 Pressure side
- 5 Tapered shaft
1 : 5; Ø 20 mm
(see page 5)

Front bearing, theoretical service life

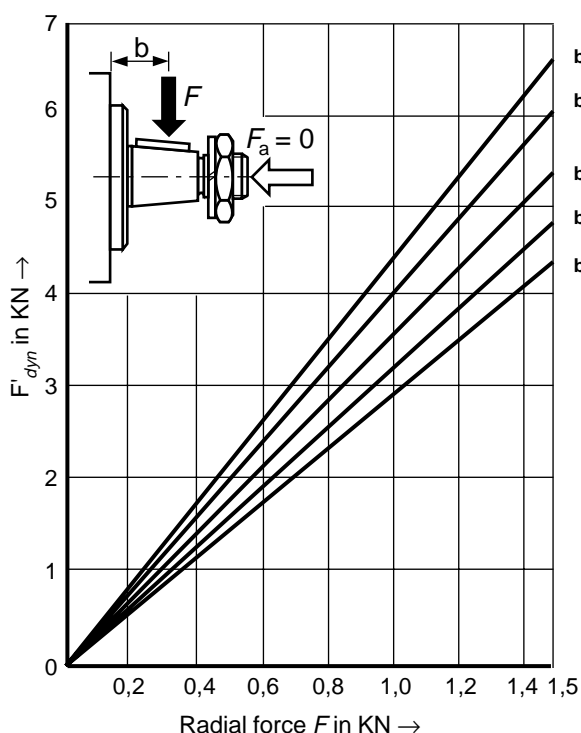

$$L_h = \frac{10^6}{n \cdot 60} \left(\frac{C_{dyn}}{F'_{dyn}} \right)^3$$

- n = Speed in min^{-1}
- L_h = Theoretical bearing life in hours
- F'_{dyn} = Equivalent dynamic load
- C_{dyn} = Dynamic load constant 21,2 kN

Unit dimensions, ordering details: (dimensions in mm, A = preferred types)

1 PF 2 G2-4X/... R H 30 MO

NS (see table)

Direction of rotation:

Clockwise = R

Anti-clockwise = L

Tapered shaft

1 : 8 ; Ø 17.4 mm

NS	Dimensions						Material no.		Weight in kg
	B	L	C	D	E	F	Clockwise	Anti-clockwise	
004	41.8	87.5	13.5	30.2	M6	13	00530858 A	On request	2.6
005	41	92.5	13.5	30.2	M6	13	00530859 A	On request	2.6
008	44.8	92.5	13.5	30.2	M6	13	00530860 A	On request	2.8
011	46.8	97.5	13.5	30.2	M6	13	00530861 A	00530887	2.9
014	49	102.5	20	39.7	M8	16	00530862 A	On request	3.0
016	48.5	107.5	20	39.7	M8	16	00530863 A	On request	3.1
019	50.5	112.5	20	39.7	M8	16	00530864 A	On request	3.2
022	55	117.5	20	39.7	M8	16	00530865 A	On request	3.3

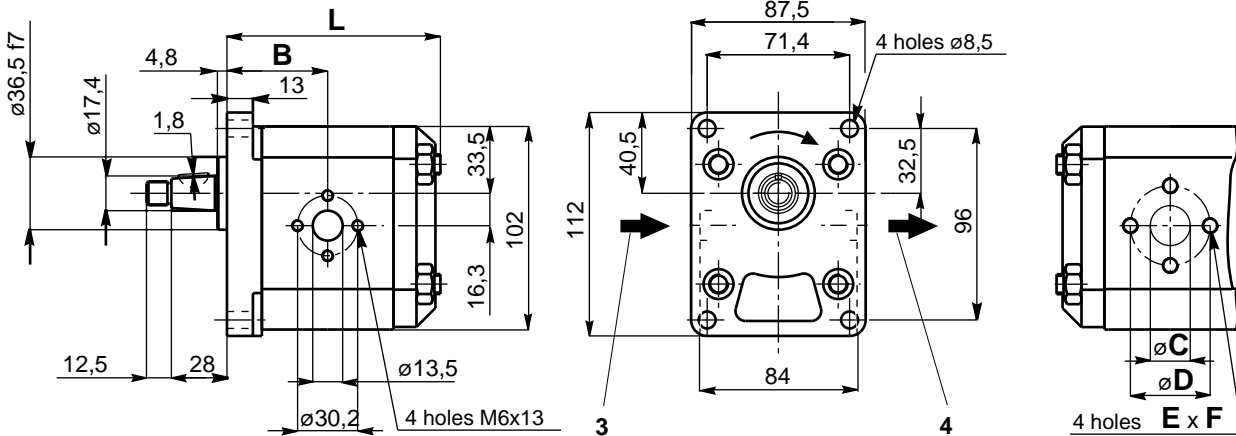

Direction of rotation: Clockwise (version "R") viewed on the shaft end
 With anti-clockwise rotation version "L" the suction and pressure ports are exchanged !

- 3 Suction side
- 4 Pressure side
- 5 Tapered shaft
1:8 ; Ø 17.4 mm (see page 6)

Seal kits (NBR)

Pump type (all nominal sizes)	Seal kit Material no.	Shaft seal Material no.
1 PF 2 G2-4X/...C 20 MB	00309401	00001855
1 PF 2 G2-4X/...C 20 KP	00309402	00013133 (FKM)
1 PF 2 G2-4X/...R 20 MR	00309401	00001855
1 PF 2 G2-4X/...S 20 MA	00309403	00005721
1 PF 2 G2-4X/...N 20 MM	00309401	-
1 PF 2 G2-4X/...H 30 MO	00309401	00001855
1 PF 2 G2-4X/...A 01 MS	00309401	00001855

Pump type (all nominal size)	Seal kit Material- no.	Shaft seal Material no.
1 PF 2 G2-4X/...C 20 MBK	00309401	00001855
1 PF 2 G2-4X/...C 20 KPK	00309402	00013133 (FKM)
1 PF 2 G2-4X/...R 20 MRK	00309401	00001855
1 PF 2 G2-4X/...N 20 MDL	00309401	00001855
1 PF 2 G2-4X/...N 20 MDN	00309401	00001855
1 PF 2 G2-4X/...H 30 MDK	00309401	00001855
1 PF 2 G2-4X/...A 01 MSK	00309401	00001855

Flange fittings for line connections

Straight flange fitting

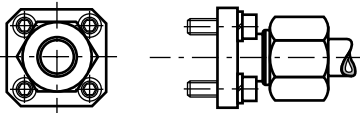

Suction side		Pressure side	
Pipe-Ø	Material no.	Pipe-Ø	Material no.
15	00321433	10	321436
18	00321434	12	321437
22	00321435	15	321438
28	00323237	16	323235

All fittings are supplied complete with screws, O-ring, cutting ring and nut

Angled flange fitting

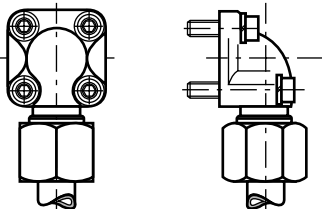

Suction side		Pressure side	
Pipe-Ø	Material no.	Pipe-Ø	Material no.
-	-	10	00321444
15	00321440	12	00321445
18	00321441	15	00321446
22	00321442	16	00321447
28	00321443	20	00321448

For technical data see RN 206.21