

MicroLogix 1762-IQ16 DC Input Module

Catalog Number 1762-IQ16

Table of Contents

Topic	Page
Important User Information	2
North American Hazardous Location Approval	4
Additional Resources	5
Overview	6
Module Description	7
Mount the Module	8
Field Wiring Connections	11
Grounding the Module	11
Wiring the Finger-Safe Terminal Block	13
I/O Memory Mapping	14
Specifications	15

Mount the Module

General Considerations

Most applications require installation in an industrial enclosure to reduce the effects of electrical interference and environmental exposure. Locate your controller as far as possible from power lines, load lines, and other sources of electrical noise such as hard-contact switches, relays, and AC motor drives. For more information on proper grounding guidelines, see the Industrial Automation Wiring and Grounding Guidelines, publication [1770-4.1](#).

ATTENTION



This product is intended to be mounted to a well-grounded mounting surface such as a metal panel. Additional grounding connections from the power supply's mounting tabs or DIN rail (if used) are not required unless the mounting surface cannot be grounded. Refer to Industrial Automation Wiring and Grounding Guidelines, Allen-Bradley publication [1770-4.1](#), for additional information.

Mounting Dimensions

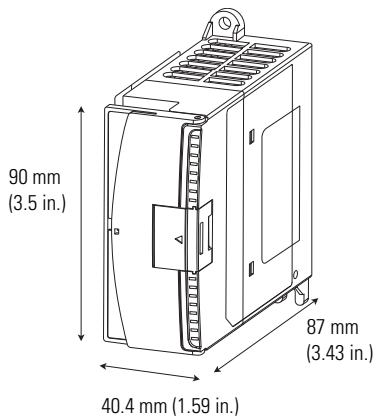

45166

Measurements do not include mounting feet or DIN rail latches.

Specifications

General

Attribute	Value
Dimensions, HxWxD	90 x 40.4 x 87 mm (3.54 x 1.59 x 3.43 in.)
Shipping weight, approx.	230g (8.11 oz)
Wire size	See Wire Size and Terminal Screw Torque on page 13
Wiring category ⁽¹⁾	2 - on signal ports
Pilot duty rating	Not rated
Enclosure type rating	IP20
North American temp code	T3C

⁽¹⁾ Use this Conductor Category information for planning conductor routing. Refer to Industrial Automation Wiring and Grounding Guidelines, publication [1770-4.1](#).

Input

Attribute	Value
Voltage category	24V DC (sink/source) ⁽¹⁾
Operating voltage range	10...30V DC 10...26.4V DC. See Derating Charts on page 17 .
Number of inputs	16
Bus current draw, max	70 mA @ 5V DC (0.35 W)
Heat dissipation, max.	5.4 Total Watts @ 30V DC 4.3 Total Watts @ 26.4V DC
Signal delay, max	On Delay: 8.0 ms Off Delay: 8.0 ms
Off-State voltage, max	5V DC
Off-State current, max	1.5 mA
On-State voltage, min	10V DC
On-State current	2.0 mA min @ 10V DC 8.0 mA nom @ 24V DC 12.0 mA max @ 30V DC
Nominal impedance	3K ohm
IEC input compatibility	Type 1
Isolated groups	Group 1: inputs 0...7; Group 2: inputs 8...15
Input group to backplane Isolation	Verified by one of the following dielectric tests: 1200V AC for 1s or 1697V DC for 1s 75V DC working voltage (IEC Class 2 reinforced insulation)