

# 1756 ControlLogix I/O Specifications

AC Digital Catalog Numbers	1756-IA8D, 1756-IA16, 1756-IA16K, 1756-IA16I, 1756-IA16IK, 1756-IA32, 1756-IA32K, 1756-IM16I, 1756-IM16IK, 1756-IN16, 1756-OA8, 1756-OA8D, 1756-OA8E, 1756-OA16, 1756-OA16K, 1756-OA16I, 1756-OA16IK, 1756-ON8
DC Digital Catalog Numbers	1756-IB16, 1756-IB16K, 1756-IB16D, 1756-IB16DK, 1756-IB16I, 1756-IB16IK, 1756-IB16IF, 1756-IB16IFK, 1756-IB16ISOE, 1756-IB16ISOEK, 1756-IB32, 1756-IB32K, 1756-IC16, 1756-IG16, 1756-IH16I, 1756-IH16ISOE, 1756-IV16, 1756-IV16K, 1756-IV32, 1756-IV32K, 1756-OB8, 1756-OB8EI, 1756-OB8I, 1756-OB16D, 1756-OB16DK, 1756-OB16E, 1756-OB16EK, 1756-OB16I, 1756-OB16IEF, 1756-OB16IEFK, 1756-OB16IEFS, 1756-OB16IS, 1756-OB32, 1756-OB32K, 1756-OC8, 1756-OG16, 1756-OH8I, 1756-OV16E, 1756-OV32E
Safety Catalog Numbers	1756-IB16S, 1756-OBV8S
Contact Catalog Numbers	1756-OW16I, 1756-OX8I
Analog Catalog Numbers	1756-IF6CIS, 1756-IF6I, 1756-IF8, 1756-IF8K, 1756-IF8I, 1756-IF8IK, 1756-IF16, 1756-IF16K, 1756-IF4FXOF2F, 1756-IF4FXOF2FK, 1756-IR6I, 1756-IRT8I, 1756-IRT8IK, 1756-IR12, 1756-IR12K, 1756-IT6I, 1756-IT6I2, 1756-IT16, 1756-IT16K, 1756-OF4, 1756-OF4K, 1756-OF6CI, 1756-OF6VI, 1756-OF8, 1756-OF8K, 1756-OF8I, 1756-OF8IK
HART Interface Catalog Numbers	1756-IF8H, 1756-IF8HK, 1756-IF8IH, 1756-IF8IHK, 1756-IF16H, 1756-IF16HK, 1756-IF16IH, 1756-IF16IHK, 1756-OF8H, 1756-OF8HK, 1756-OF8IH, 1756-OF8IHK
Specialty Catalog Numbers	1756-CFM, 1756-CMS1B1, 1756-CMS1C1, 1756-HSC, 1756-LSC8XIB8I, 1756-LSC8XIB8IK, 1756-PLS

Topic	Page
Summary of Changes	2
Available 1756 I/O Modules	3
ControlLogix I/O Accessories	270
Additional Resources	272

The ControlLogix® Architecture provides a wide range of input and output modules to span many applications, from high-speed digital to process control. The ControlLogix architecture uses Producer/Consumer technology, which allows input information and output status to be shared among multiple ControlLogix controllers.



I/O Type	Cat. No.	Page	Cat. No.	Page
AC digital	1756-IA8D	5	1756-OA8	130
	1756-IA16, 1756-IA16K	8	1756-OA8D	133
	1756-IA16I, 1756-IA16IK	11	1756-OA8E	136
	1756-IA32, 1756-IA32K	14	1756-OA16, 1756-OA16K	139
	1756-IM16I, 1756-IM16IK	90	1756-OA16I, 1756-OA16IK	143
	1756-IN16	93	1756-ON8	214
DC digital	1756-IB16, 1756-IB16K	17	1756-OB8	146
	1756-IB16D, 1756-IB16DK	20	1756-OB8EI	149
	1756-IB16I, 1756-IB16IK	23	1756-OB8I	152
	1756-IB16IF, 1756-IB16IFK	27	1756-OB16D, 1756-OB16DK	155
	1756-IB16ISOE, 1756-IB16ISOEK	30	1756-OB16E, 1756-OB16EK	159
	1756-IB32, 1756-IB32K	33	1756-OB16I	163
	1756-IC16	36	1756-OB16IEF, 1756-OB16IEFK	166
	1756-IG16	81	1756-OB16IEFS	169
	1756-IH16I	84	1756-OB16IS	172
	1756-IH16ISOE	87	1756-OB32, 1756-OB32K	175
	1756-IV16, 1756-IV16K	124	1756-OC8	178
	1756-IV32, 1756-IV32K	127	1756-OG16	208
			1756-OH8I	211
			1756-OV16E	218
			1756-OV32E	222
	Safety	1756-IB16S	226	1756-OBV8S
Contact			1756-OW16I	244
			1756-OX8I	247
Analog	1756-IF6CIS	43		
	1756-IF6I	47		
	1756-IF8, 1756-IF8K	51		
	1756-IF8I, 1756-IF8IK	59	1756-OF4, 1756-OF4K	181
	1756-IF16, 1756-IF16K	68	1756-OF6CI	185
	1756-IF4FXOF2F, 1756-IF4FXOF2FK	39	1756-OF6VI	189
	1756-IR6I	96	1756-OF8, 1756-OF8K	192
	1756-IRT8I, 1756-IRT8IK	101	1756-OF8I, 1756-OF8IK	200
	1756-IR12, 1756-IR12K	107		
	1756-IT6I	111		
	1756-IT6I2	115		
1756-IT16, 1756-IT16K	119			
HART interface	1756-IF8H, 1756-IF8HK	56	1756-OF8H, 1756-OF8HK	196
	1756-IF8IH, 1756-IF8IHK	64	1756-OF8IH, 1756-OF8IHK	204
	1756-IF16H, 1756-IF16HK	73		
	1756-IF16IH, 1756-IF16IHK	77		
Specialty	1756-CFM	250	1756-LSC8XIB8I, 1756-LSC8XIB8IK	261
	1756-CMS1B1, 1756-CMS1C1	255	1756-PLS	265
	1756-HSC	257		

**Environmental Specifications - 1756-IA16, 1756-IA16K**

Attribute	1756-IA16, 1756-IA16K
Surge transient immunity IEC 61000-4-5	$\pm 1$ kV line-line (DM) and $\pm 2$ kV line-earth (CM) on signal ports
Conducted RF immunity IEC 61000-4-6	10V rms with 1 kHz sine-wave 80% AM from 150 kHz . . . 80 MHz
Oscillatory surge withstand IEEE C37.90.1	3 kV

**Certifications - 1756-IA16, 1756-IA16K**

Certification (when product is marked) <sup>(1)</sup>	1756-IA16, 1756-IA16K
UL	UL Listed Industrial Control Equipment. See UL File E65584.
CSA	CSA Certified Process Control Equipment. See CSA File LR54689C. CSA Certified Process Control Equipment for Class I, Division 2 Group A,B,C,D Hazardous Locations. See CSA File LR69960C.
CE	European Union 2014/30/EU EMC Directive, compliant with: <ul style="list-style-type: none"> <li>• EN 61326-1; Meas./Control/Lab., Industrial Requirements</li> <li>• EN 61000-6-2; Industrial Immunity</li> <li>• EN 61000-6-4; Industrial Emissions</li> <li>• EN 61131-2; Programmable Controllers (Clause 8, Zone A &amp; B)</li> </ul> European Union 2014/35/EU LVD, compliant with: EN 61131-2; Programmable Controllers (Clause 11)
RCM	Australian Radiocommunications Act, compliant with: EN 61000-6-4; Industrial Emissions
FM	FM Approved Equipment for use in Class I Division 2 Group A,B,C,D Hazardous Locations
KC	Korean Registration of Broadcasting and Communications Equipment, compliant with: Article 58-2 of Radio Waves Act, Clause 3
EAC	Russian Customs Union TR CU 020/2011 EMC Technical Regulation Russian Customs Union TR CU 004/2011 LV Technical Regulation

(1) See the Product Certification link at [rok.auto/certifications](http://rok.auto/certifications) for Declarations of Conformity, Certificates, and other certification details.

## 1756-IA16I, 1756-IA16IK

ControlLogix 120V AC isolated input module

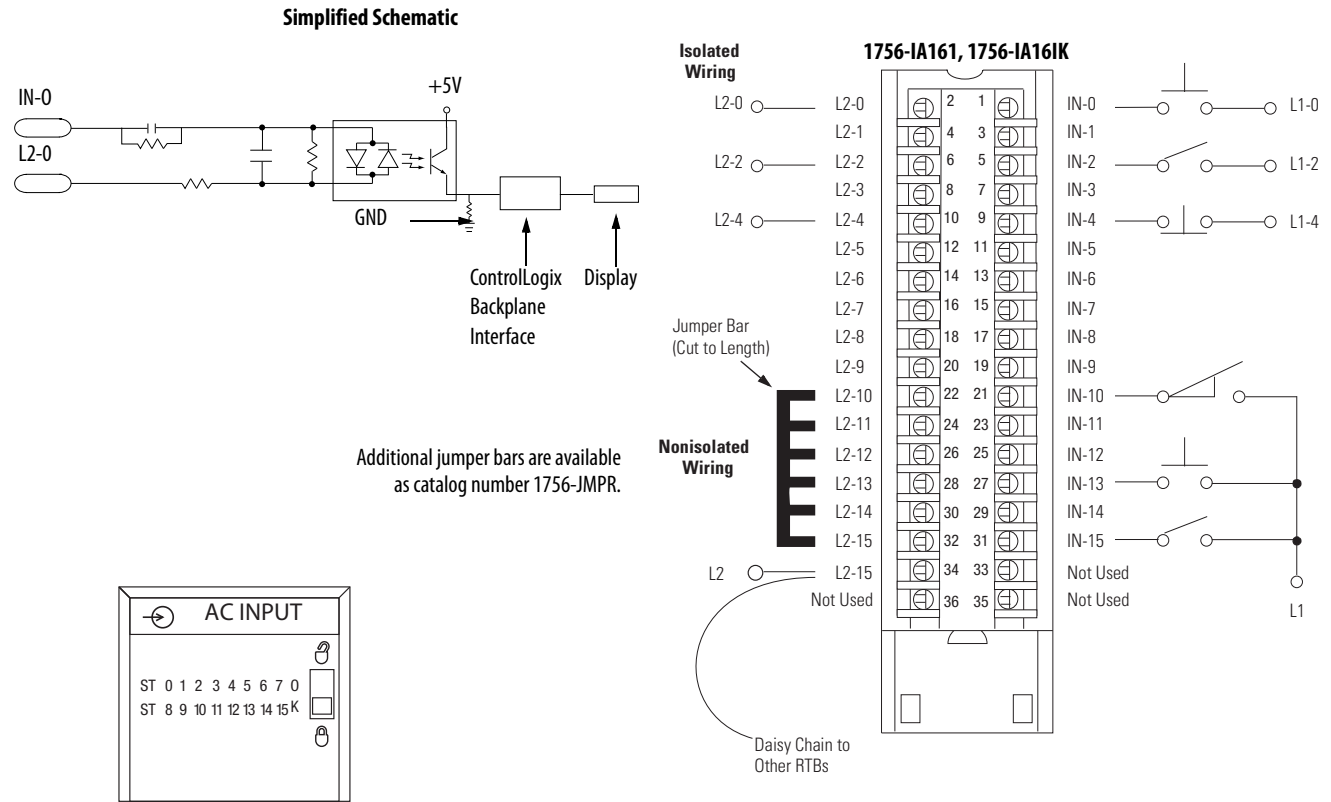

### Technical Specifications - 1756-IA16I, 1756-IA16IK

Attribute	1756-IA16I, 1756-IA16IK
Inputs	16 individually isolated
Voltage category	120V AC 50/60 Hz
Operating voltage range <sup>(1)</sup>	79...132V AC, 47...63 Hz
Input voltage, nom	120V AC 50/60 Hz
Input delay time (screw to backplane)	
Off to On	Hardware delay: 10 ms max + filter time User-selectable filter time: 1 ms or 2 ms
On to Off	Hardware delay: 8 ms max + filter time User-selectable filter time: 9 ms or 18 ms
Current draw @ 5.1V	125 mA
Current draw @ 24V	3 mA
Total backplane power	0.71 W
Power dissipation, max	4.9 W @ 60 °C (140 °F)
Thermal dissipation	16.71 BTU/hr
Off-state voltage, max	20V

**Technical Specifications - 1756-IA16I, 1756-IA16IK**

Attribute	1756-IA16I, 1756-IA16IK
Off-state current, max	2.5 mA
On-state current, min	5 mA @ 79V AC, 47...63 Hz
On-state current, max	15 mA @ 132V AC, 47...63 Hz
Inrush current, max	250 mA
Input impedance, max	8.8 k $\Omega$ @ 132V AC, 60 Hz
Cyclic update time	200 $\mu$ s...750 ms
Change of state	Software configurable
Time stamp of inputs	$\pm$ 200 $\mu$ s
Isolation voltage	125V (continuous), basic insulation type, inputs-to-backplane, and input-to-input
Module keying	Electronic, software configurable
Removable terminal block housing	1756-TBCH 1756-TBS6H
RTB keying	User-defined mechanical
Slot width	1
Wire category <sup>(2)</sup>	1 - on signal ports
Enclosure type	None (open-style)
North American temperature code	T4A

(1) UL certification for 120V 50/60 Hz nominal. Rockwell Automation specified to 74...132V, 47...63 Hz.

(2) Use this conductor category information for planning conductor routing as described in the system-level installation manual. See the Industrial Automation Wiring and Grounding Guidelines, publication [1770-4.1](#).

**Environmental Specifications - 1756-IA16I, 1756-IA16IK**

Attribute	1756-IA16I, 1756-IA16IK
Temperature, operating IEC 60068-2-1 (Test Ad, Operating Cold), IEC 60068-2-2 (Test Bd, Operating Dry Heat), IEC 60068-2-14 (Test Nb, Operating Thermal Shock)	0...60 °C (32...140 °F)
Temperature, surrounding air, max	60 °C (140 °F)
Temperature, nonoperating IEC 60068-2-1 (Test Ab, Unpackaged Nonoperating Cold), IEC 60068-2-2 (Test Bb, Unpackaged Nonoperating Dry Heat), IEC 60068-2-14 (Test N/A, Unpackaged Nonoperating Thermal Shock)	-40...+85 °C (-40...+185 °F)
Relative humidity IEC 60068-2-30 (Test dB, Unpackaged Damp Heat)	5...95% noncondensing
Vibration IEC 60068-2-6 (Test Fc, Operating)	2 g @ 10...500 Hz
Shock, operating IEC 60068-2-27 (Test Ea, Unpackaged Shock)	30 g
Shock, nonoperating IEC 60068-2-27 (Test Ea, Unpackaged Shock)	50 g
Emissions	IEC 61000-6-4
ESD immunity IEC 61000-4-2	6 kV contact discharges 8 kV air discharges

**Environmental Specifications - 1756-IA16I, 1756-IA16IK**

Attribute	1756-IA16I, 1756-IA16IK
Radiated RF immunity IEC 61000-4-3	10V/m with 1 kHz sine-wave 80% AM from 80...2000 MHz 10V/m with 200 Hz 50% Pulse 100% AM @ 900 MHz 10V/m with 200 Hz 50% Pulse 100% AM @ 1890 MHz 3V/m with 1 kHz sine-wave 80% AM from 2000...2700 MHz
EFT/B immunity IEC 61000-4-4	±4 kV at 5 kHz on signal ports
Surge transient immunity IEC 61000-4-5	±1 kV line-line (DM) and ±2 kV line-earth (CM) on signal ports
Conducted RF immunity IEC 61000-4-6	10V rms with 1 kHz sine-wave 80% AM from 150 kHz...80 MHz
Oscillatory surge withstand IEEE C37.90.1	3 kV

**Certifications - 1756-IA16I, 1756-IA16IK**

Certification (when product is marked) <sup>(1)</sup>	1756-IA16I, 1756-IA16IK
UL	UL Listed Industrial Control Equipment. See UL File E65584.
CSA	CSA Certified Process Control Equipment. See CSA File LR54689C. CSA Certified Process Control Equipment for Class I, Division 2 Group A,B,C,D Hazardous Locations. See CSA File LR69960C.
CE	European Union 2014/30/EU EMC Directive, compliant with: <ul style="list-style-type: none"> <li>EN 61131-2; Programmable Controllers (Clause 8, Zone A &amp; B)</li> <li>EN 61326-1; Meas./Control/Lab., Industrial Requirements</li> <li>EN 61000-6-2; Industrial Immunity</li> <li>EN 61000-6-4; Industrial Emissions</li> </ul> European Union 2014/35/EU LVD Directive, compliant with: EN 61131-2; Programmable Controllers (Clause 11)
RCM	Australian Radiocommunications Act, compliant with: EN 61000-6-4; Industrial Emissions
FM	FM Approved Equipment for use in Class I Division 2 Group A,B,C,D Hazardous Locations
KC	Korean Registration of Broadcasting and Communications Equipment, compliant with: Article 58-2 of Radio Waves Act, Clause 3
EAC	Russian Customs Union TR CU 020/2011 EMC Technical Regulation Russian Customs Union TR CU 004/2011 LV Technical Regulation

(1) See the Product Certification link at [rok.auto/certifications](http://rok.auto/certifications) for Declarations of Conformity, Certificates, and other certification details.

## 1756-IA32, 1756-IA32K

ControlLogix AC (74...132V) input module

**Simplified Schematic**

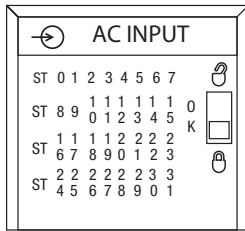
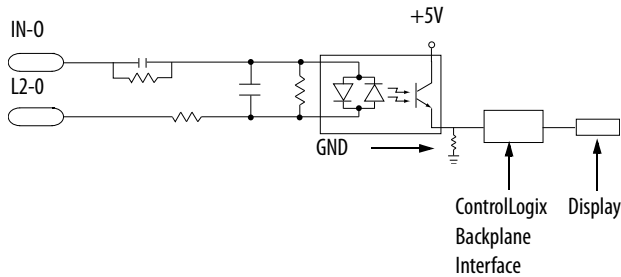

**1756-IA32, 1756-IA32K**

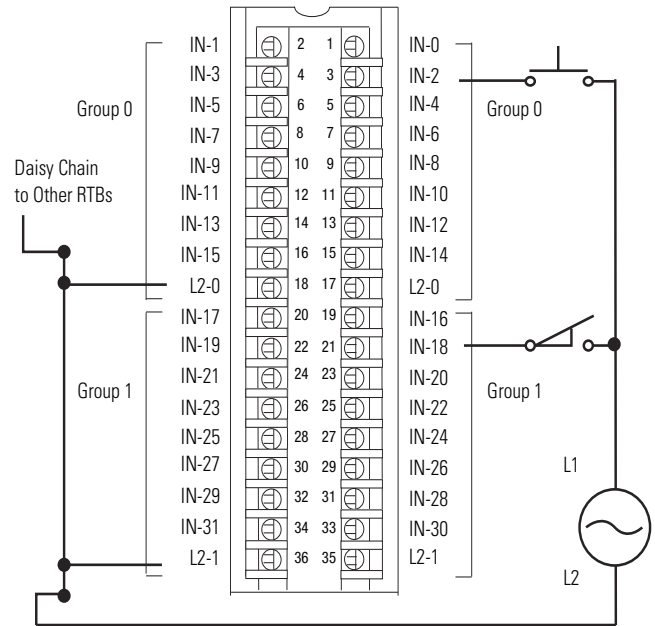

### Technical Specifications - 1756-IA32, 1756-IA32K

Attribute	1756-IA32, 1756-IA32K
Inputs	32 (16 points/group)
Voltage category	120V AC 50/60 Hz
Operating voltage range	74...132V AC, 47...63 Hz
Input voltage, nom	120V AC 50/60 Hz
Input delay time (screw to backplane)	
Off to On	Hardware delay: 1.5 ms nom/10 ms max + filter time User-selectable filter time: 1 ms or 2 ms
On to Off	Hardware delay: 1 ms nom/8 ms max + filter time User-selectable filter time: 9 ms or 18 ms
Current draw @ 5.1V	165 mA
Current draw @ 24V	2 mA
Total backplane power	0.9 W
Power dissipation, max	6.1 W @ 60 °C (140 °F)
Thermal dissipation	20.8 BTU/hr
Off-state voltage, max	20V
Off-state current, max	2.5 mA
On-state current, min	5 mA @ 74V AC

**Technical Specifications - 1756-IA32, 1756-IA32K**

Attribute	1756-IA32, 1756-IA32K
On-state current, max	15 mA @ 132V AC
Inrush current, max	390 mA
Input impedance, max	14.0 k $\Omega$ @ 132V AC, 60 Hz
Cyclic update time	200 $\mu$ s...750 ms
Change of stat	Software configurable
Time stamp of inputs	$\pm$ 200 $\mu$ s
Isolation voltage	250V (continuous), basic insulation type, inputs-to-backplane 125V (continuous), basic insulation type, input group-to-group No isolation between individual group inputs
Module keying	Electronic, software configurable
Removable terminal block housing	1756-TBCH 1756-TBS6H
RTB keying	User-defined mechanical
Slot width	1
Wire category <sup>(1)</sup>	1 - on signal ports
Enclosure type	None (open-style)
North American temperature code	T4

(1) Use this Conductor Category information for planning conductor routing. Refer to Industrial Automation Wiring and Grounding Guidelines, publication [1770-4.1](#).

**Environmental Specifications - 1756-IA32, 1756-IA32K**

Attribute	1756-IA32, 1756-IA32K
Temperature, operating IEC 60068-2-1 (Test Ad, Operating Cold), IEC 60068-2-2 (Test Bd, Operating Dry Heat), IEC 60068-2-14 (Test Nb, Operating Thermal Shock)	0...60 °C (32...140 °F)
Temperature, surrounding air, max	60 °C (140 °F)
Temperature, nonoperating IEC 60068-2-1 (Test Ab, Unpackaged Nonoperating Cold), IEC 60068-2-2 (Test Bb, Unpackaged Nonoperating Dry Heat), IEC 60068-2-14 (Test N/A, Unpackaged Nonoperating Thermal Shock)	-40...+85 °C (-40...+185 °F)
Relative humidity IEC 60068-2-30 (Test dB, Unpackaged Damp Heat)	5...95% noncondensing
Vibration IEC 60068-2-6 (Test Fc, Operating)	2 g @ 10...500 Hz
Shock, operating IEC 60068-2-27 (Test Ea, Unpackaged Shock)	30 g
Shock, nonoperating IEC 60068-2-27 (Test Ea, Unpackaged Shock)	50 g
Emissions	IEC 61000-6-4
ESD immunity IEC 61000-4-2	6 kV contact discharges 8 kV air discharges
Radiated RF immunity IEC 61000-4-3	10V/m with 1 kHz sine-wave 80% AM from 80...2000 MHz 10V/m with 200 Hz 50% Pulse 100% AM @ 900 MHz 10V/m with 200 Hz 50% Pulse 100% AM @ 1890 MHz 3V/m with 1 kHz sine-wave 80% AM from 2000...2700 MHz



**Environmental Specifications - 1756-IA32, 1756-IA32K**

Attribute	1756-IA32, 1756-IA32K
EFT/B immunity IEC 61000-4-4	±4 kV at 5 kHz on signal ports
Surge transient immunity IEC 61000-4-5	±1 kV line-line (DM) and ±2 kV line-earth (CM) on signal ports
Conducted RF immunity IEC 61000-4-6	10V rms with 1 kHz sine-wave 80% AM from 150 kHz . . . 80 MHz

**Certifications - 1756-IA32, 1756-IA32K**

Certification (when product is marked) <sup>(1)</sup>	1756-IA32, 1756-IA32K
UL	UL Listed Industrial Control Equipment. See UL File E65584.
CSA	CSA Certified Process Control Equipment. See CSA File LR54689C. CSA Certified Process Control Equipment for Class I, Division 2 Group A,B,C,D Hazardous Locations. See CSA File LR69960C.
CE	European Union 2014/30/EU EMC Directive, compliant with: <ul style="list-style-type: none"> <li>• EN 61326-1; Meas./Control/Lab., Industrial Requirements</li> <li>• EN 61000-6-2; Industrial Immunity</li> <li>• EN 61000-6-4; Industrial Emissions</li> <li>• EN 61131-2; Programmable Controllers (Clause 8, Zone A &amp; B)</li> </ul> European Union 2014/35/EU LVD, compliant with: EN 61131-2; Programmable Controllers (Clause 11)
RCM	Australian Radiocommunications Act, compliant with: EN 61000-6-4; Industrial Emissions
KC	Korean Registration of Broadcasting and Communications Equipment, compliant with: Article 58-2 of Radio Waves Act, Clause 3
EAC	Russian Customs Union TR CU 020/2011 EMC Technical Regulation Russian Customs Union TR CU 004/2011 LV Technical Regulation

(1) See the Product Certification link at [rok.auto/certifications](http://rok.auto/certifications) for Declarations of Conformity, Certificates, and other certification details.

## 1756-IB16, 1756-IB16K

ControlLogix DC (10...31.2V) input module

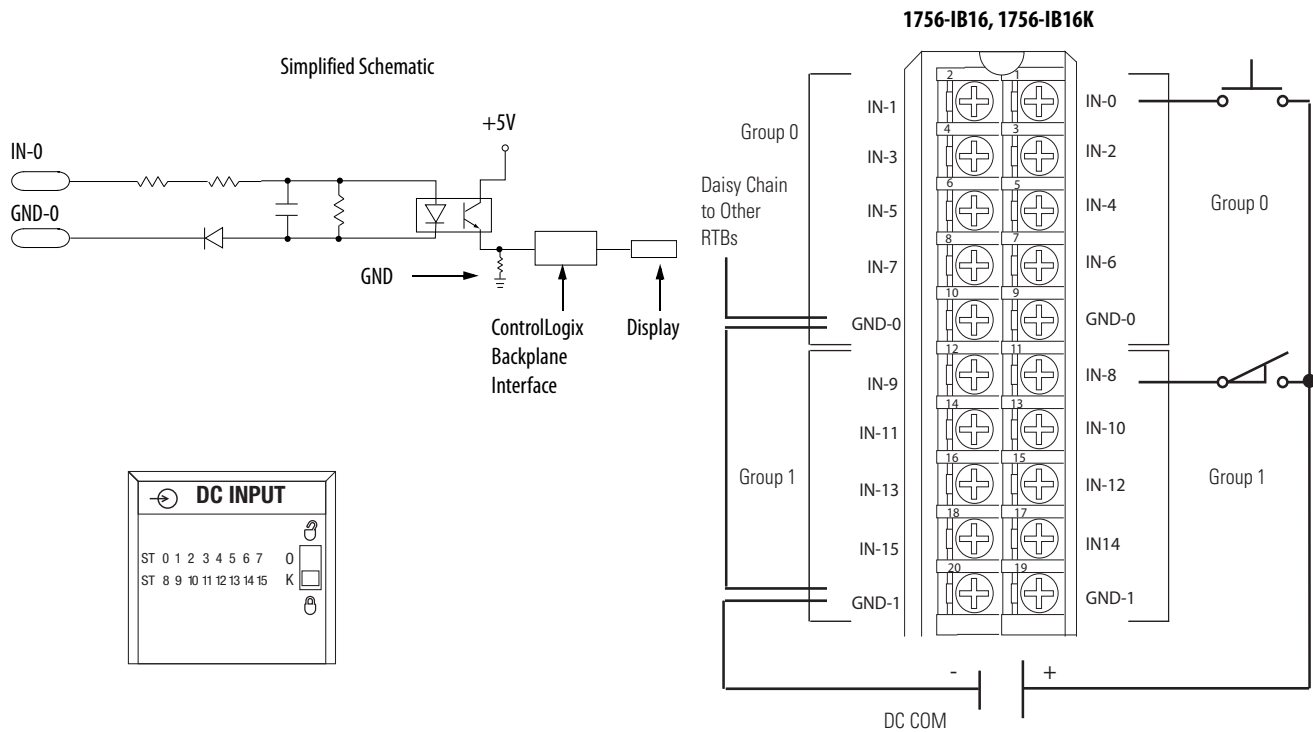

### Technical Specifications - 1756-IB16, 1756-IB16K

Attribute	1756-IB16, 1756-IB16K
Inputs	16 (8 points/group)
Voltage category	12/24V DC sink
Operating voltage range	10...31.2V DC
Input voltage, nom	24V DC
Input delay time (screw to backplane)	
Off to On	Hardware delay: 290 $\mu$ s nom/1 ms max + filter time User-selectable filter time: 0 ms, 1 ms, or 2 ms
On to Off	Hardware delay: 700 $\mu$ s nom/2 ms max + filter time User-selectable filter time: 0, 1, 2, 9, or 18 ms
Current draw @ 5.1V	100 mA
Current draw @ 24V	2 mA
Total backplane power	0.56 W
Power dissipation, max	5.1 W @ 60 °C (140 °F)
Thermal dissipation	17.39 BTU/hr
Off-state voltage, max	5V
Off-state current, max	1.5 mA
On-state current, min	2 mA @ 10V DC
On-state current, max	10 mA @ 31.2V DC

**Technical Specifications - 1756-IB16, 1756-IB16K**

Attribute	1756-IB16, 1756-IB16K
Inrush current, max	250 mA peak (decaying to < 37% in 22 ms, without activation)
Input impedance, max	3.12 k $\Omega$ @ 31.2V DC
Cyclic update time	200 $\mu$ s...750 ms
Change of state	Software configurable
Time stamp of inputs	$\pm$ 200 $\mu$ s
Isolation voltage	250V (continuous), basic insulation type, inputs-to-backplane, and input group-to-group No isolation between individual group inputs
Module keying	Electronic, software configurable
Removable terminal block housing	1756-TBNH 1756-TBSH
RTB keying	User-defined mechanical
Slot width	1
Wire category	1 <sup>(1)</sup>
Enclosure type	None (open-style)
North American temperature code	T3C
IEC temperature code	T3
Reverse polarity protection	Yes

(1) Use this conductor category information for planning conductor routing as described in the system-level installation manual. See the Industrial Automation Wiring and Grounding Guidelines, publication [1770-4.1](#).

**Environmental Specifications - 1756-IB16, 1756-IB16K**

Attribute	1756-IB16, 1756-IB16K
Temperature, operating IEC 60068-2-1 (Test Ad, Operating Cold), IEC 60068-2-2 (Test Bd, Operating Dry Heat), IEC 60068-2-14 (Test Nb, Operating Thermal Shock)	0...60 °C (32...140 °F)
Temperature, surrounding air, max	60 °C (140 °F)
Temperature, nonoperating IEC 60068-2-1 (Test Ab, Unpackaged Nonoperating Cold), IEC 60068-2-2 (Test Bb, Unpackaged Nonoperating Dry Heat), IEC 60068-2-14 (Test N/A, Unpackaged Nonoperating Thermal Shock)	-40...+85 °C (-40...+185 °F)
Relative humidity IEC 60068-2-30 (Test dB, Unpackaged Damp Heat)	5...95% noncondensing
Vibration IEC 60068-2-6 (Test Fc, Operating)	2 g @ 10...500 Hz
Shock, operating IEC 60068-2-27 (Test Ea, Unpackaged Shock)	30 g
Shock, nonoperating IEC 60068-2-27 (Test Ea, Unpackaged Shock)	50 g
Emissions	IEC 61000-6-4
ESD immunity IEC 61000-4-2	6 kV contact discharges 8 kV air discharges
Radiated RF immunity IEC 61000-4-3	10V/m with 1 kHz sine-wave 80% AM from 80...2000 MHz 10V/m with 200 Hz 50% Pulse 100% AM @ 900 MHz 10V/m with 200 Hz 50% Pulse 100% AM @ 1890 MHz 3V/m with 1 kHz sine-wave 80% AM from 2000...2700 MHz

**Environmental Specifications - 1756-IB16, 1756-IB16K**

Attribute	1756-IB16, 1756-IB16K
EFT/B immunity IEC 61000-4-4	±4 kV at 5 kHz on signal ports
Surge transient immunity IEC 61000-4-5	±1 kV line-line (DM) and ±2 kV line-earth (CM) on signal ports
Conducted RF immunity IEC 61000-4-6	10V rms with 1 kHz sine-wave 80% AM from 150 kHz . . . 80 MHz
Oscillatory surge withstand IEEE C37.90.1	3 kV

**Certifications - 1756-IB16, 1756-IB16K**

Certification (when product is marked) <sup>(1)</sup>	1756-IB16, 1756-IB16K
UL	UL Listed Industrial Control Equipment. See UL File E65584.
CSA	CSA Certified Process Control Equipment. See CSA File LR54689C. CSA Certified Process Control Equipment for Class I, Division 2 Group A,B,C,D Hazardous Locations. See CSA File LR69960C.
CE	European Union 2014/30/EU EMC Directive, compliant with: <ul style="list-style-type: none"> <li>• EN 61326-1; Meas./Control/Lab., Industrial Requirements</li> <li>• EN 61000-6-2; Industrial Immunity</li> <li>• EN 61000-6-4; Industrial Emissions</li> <li>• EN 61131-2; Programmable Controllers (Clause 8, Zone A &amp; B)</li> </ul> European Union 2014/35/EU LVD, compliant with: EN 61131-2; Programmable Controllers (Clause 11)
RCM	Australian Radiocommunications Act, compliant with: EN 61000-6-4; Industrial Emissions
Ex	European Union 2014/34/EU ATEX Directive, compliant with: <ul style="list-style-type: none"> <li>• EN 60079-15; Potentially Explosive Atmospheres, Protection "n"</li> <li>• EN 60079-0; General Requirements II 3 G Ex nA IIC T3 X Gc</li> </ul>
FM	FM Approved Equipment for use in Class I Division 2 Group A,B,C,D Hazardous Locations
KC	Korean Registration of Broadcasting and Communications Equipment, compliant with: Article 58-2 of Radio Waves Act, Clause 3
EAC	Russian Customs Union TR CU 020/2011 EMC Technical Regulation Russian Customs Union TR CU 004/2011 LV Technical Regulation

(1) See the Product Certification link at [rok.auto/certifications](http://rok.auto/certifications) for Declarations of Conformity, Certificates, and other certification details.

## 1756-IB16D, 1756-IB16DK

ControlLogix DC (10...30V) diagnostic input module

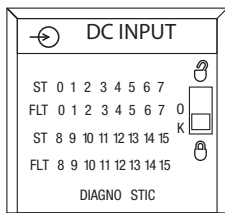
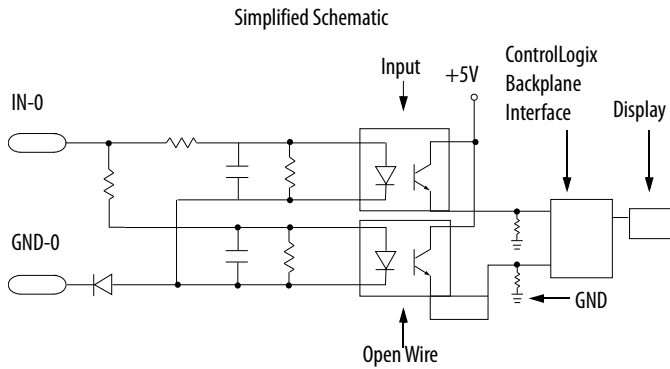

1756-IB16D, 1756-IB16DK

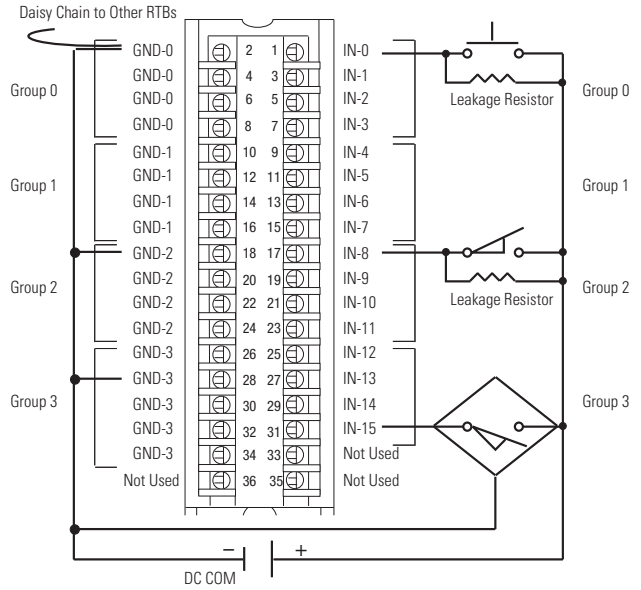

Recommended Leakage Resistor Size 1/4 W, 5%	Supply Voltage
3.9K	10V DC
5.6K	12V DC
15K	24V DC
20K	30V DC

### Diagnostic Specifications - 1756-IB16D, 1756-IB16DK

Attribute	1756-IB16D, 1756-IB16DK
Open wire	Off-state leakage current 1.2 mA min
Time stamp of diagnostics	±1 ms

### Technical Specifications - 1756-IB16D, 1756-IB16DK

Attribute	1756-IB16D, 1756-IB16DK
Inputs	Sixteen diagnostic (4 points/group)
Voltage category	12/24V DC sink
Operating voltage range	10...30V DC
Input voltage, nom	24V DC
Input delay time (screw to backplane)	
Off to On	Hardware delay: 340 μs nom/1 ms max + filter time User-selectable filter time: 0 ms, 1 ms, or 2 ms
On to Off	Hardware delay: 740 μs nom/4 ms max + filter time User-selectable filter time: 0 ms, 1 ms, 9 ms, or 18 ms

**Technical Specifications - 1756-IB16D, 1756-IB16DK**

Attribute	1756-IB16D, 1756-IB16DK
Current draw @ 5.1V	150 mA
Current draw @ 24V	3 mA
Total backplane power	0.84 W
Power dissipation, max	5.8 W @ 60 °C (140 °F)
Thermal dissipation	19.78 BTU/hr
Off-state voltage, max	5V
Off-state current, max	1.5 mA
On-state current, min	2 mA @ 10V DC
On-state current, max	13 mA @ 30V DC
Inrush current, max	250 mA
Input impedance, max	2.31 k $\Omega$ @ 30V DC
Cyclic update time	200 $\mu$ s...750 ms
Change of state	Software configurable
Time stamp of inputs	$\pm$ 200 $\mu$ s
Isolation voltage	250V (continuous), basic insulation type, inputs-to-backplane, and input group-to-group No isolation between individual group inputs
Module keying	Electronic, software configurable
Removable terminal block housing	1756-TBCH 1756-TBS6H
RTB keying	User-defined mechanical
Slot width	1
Wire category	1 <sup>(1)</sup>
Enclosure type	None (open-style)
North American temperature code	T3C
IEC temperature code	T3
Reverse polarity protection	Yes

(1) Use this conductor category information for planning conductor routing as described in the system-level installation manual. See the Industrial Automation Wiring and Grounding Guidelines, publication [1770-4.1](#).

**Environmental Specifications - 1756-IB16D, 1756-IB16DK**

Attribute	1756-IB16D, 1756-IB16DK
Temperature, operating IEC 60068-2-1 (Test Ad, Operating Cold), IEC 60068-2-2 (Test Bd, Operating Dry Heat), IEC 60068-2-14 (Test Nb, Operating Thermal Shock)	0...60 °C (32...140 °F)
Temperature, surrounding air, max	60 °C (140 °F)
Temperature, nonoperating IEC 60068-2-1 (Test Ab, Unpackaged Nonoperating Cold), IEC 60068-2-2 (Test Bb, Unpackaged Nonoperating Dry Heat), IEC 60068-2-14 (Test Na, Unpackaged Nonoperating Thermal Shock)	-40...+85 °C (-40...+185 °F)
Relative humidity IEC 60068-2-30 (Test dB, Unpackaged Damp Heat)	5...95% noncondensing
Vibration IEC 60068-2-6 (Test Fc, Operating)	2 g @ 10...500 Hz

**Environmental Specifications - 1756-IB16D, 1756-IB16DK**

Attribute	1756-IB16D, 1756-IB16DK
Shock, operating IEC 60068-2-27 (Test Ea, Unpackaged Shock)	30 g
Shock, nonoperating IEC 60068-2-27 (Test Ea, Unpackaged Shock)	50 g
Emissions	IEC 61000-6-4
ESD immunity IEC 61000-4-2	6 kV contact discharges 8 kV air discharges
Radiated RF immunity IEC 61000-4-3	10V/m with 1 kHz sine-wave 80% AM from 80...2000 MHz 10V/m with 200 Hz 50% Pulse 100% AM @ 900 MHz 10V/m with 200 Hz 50% Pulse 100% AM @ 1890 MHz 3V/m with 1 kHz sine-wave 80% AM from 2000...2700 MHz
EFT/B immunity IEC 61000-4-4	±4 kV at 5 kHz on signal ports
Surge transient immunity IEC 61000-4-5	±1 kV line-line (DM) and ±2 kV line-earth (CM) on signal ports
Conducted RF immunity IEC 61000-4-6	10V rms with 1 kHz sine-wave 80% AM from 150 kHz...80 MHz

**Certifications - 1756-IB16D, 1756-IB16DK**

Certification (when product is marked) <sup>(1)</sup>	1756-IB16D, 1756-IB16DK
UL	UL Listed Industrial Control Equipment. See UL File E65584.
CSA	CSA Certified Process Control Equipment. See CSA File LR54689C. CSA Certified Process Control Equipment for Class I, Division 2 Group A,B,C,D Hazardous Locations. See CSA File LR69960C.
CE	European Union 2014/30/EU EMC Directive, compliant with: <ul style="list-style-type: none"> <li>EN 61326-1; Meas./Control/Lab., Industrial Requirements</li> <li>EN 61000-6-2; Industrial Immunity</li> <li>EN 61000-6-4; Industrial Emissions</li> <li>EN 61131-2; Programmable Controllers (Clause 8, Zone A &amp; B)</li> </ul> European Union 2014/35/EU LVD, compliant with: EN 61131-2; Programmable Controllers (Clause 11)
RCM	Australian Radiocommunications Act, compliant with: EN 61000-6-4; Industrial Emissions
KC	Korean Registration of Broadcasting and Communications Equipment, compliant with: Article 58-2 of Radio Waves Act, Clause 3
Ex	European Union 2014/34/EU ATEX Directive, compliant with: <ul style="list-style-type: none"> <li>EN 60079-15; Potentially Explosive Atmospheres, Protection "n"</li> <li>EN 60079-0; General Requirements II 3 G Ex nA IIC T3 X Gc</li> </ul>
FM	FM Approved Equipment for use in Class I Division 2 Group A,B,C,D Hazardous Locations
EAC	Russian Customs Union TR CU 020/2011 EMC Technical Regulation Russian Customs Union TR CU 004/2011 LV Technical Regulation

(1) See the Product Certification link at [rok.auto/certifications](http://rok.auto/certifications) for Declarations of Conformity, Certificates, and other certification details.

# 1756-IB16I, 1756-IB16IK

ControlLogix DC (10...30V) isolated input module

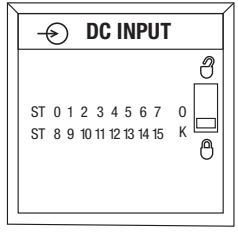
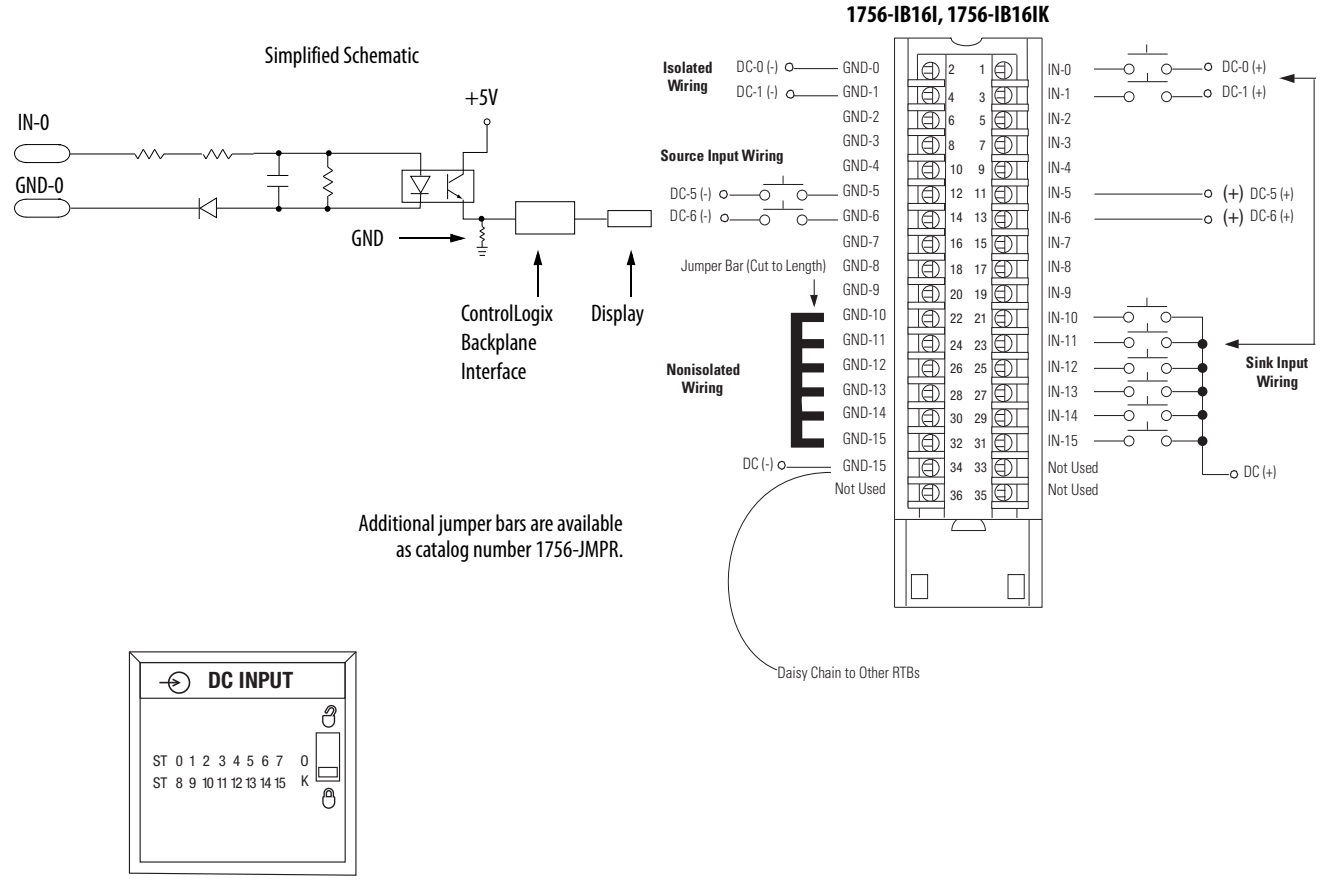



**Technical Specifications - 1756-IB16I, 1756-IB16IK**

<b>Attribute</b>	<b>1756-IB16I, 1756-IB16IK</b>
Inputs	16 individually isolated
Voltage category	12/24V DC sink/source
Operating voltage range	10...30V DC
Input voltage, nom	24V DC
Input delay time (screw to backplane)	
Off to On	Hardware delay: 1 ms max + filter time User-selectable filter time: 0 ms, 1 ms, or 2 ms
On to Off	Hardware delay: 4 ms max + filter time User-selectable filter time: 0 ms, 1 ms, 2 ms, 9 ms, or 18 ms
Current draw @ 5.1V	100 mA
Current draw @ 24V	3 mA
Total backplane power	0.58 W
Power dissipation, max	5 W @ 60 °C (140 °F)
Thermal dissipation	17.05 BTU/hr
Off-state voltage, max	5V
Off-state current, max	1.5 mA
On-state current, min	2 mA @ 10V DC
On-state current, max	10 mA @ 30V DC
Inrush current, max	250 mA peak (decaying to < 37% in 22 ms, without activation)
Input impedance, max	3 k $\Omega$ @ 30V DC
Cyclic update time	200 $\mu$ s...750 ms
Change of stat	Software configurable
Time stamp of inputs	$\pm$ 200 $\mu$ s
Isolation voltage	250V (continuous), basic insulation type, inputs-to-backplane, and input-to-input
Module keying	Electronic, software configurable
Removable terminal block housing	1756-TBCH 1756-TBS6H
RTB keying	User-defined mechanical
Slot width	1
Wire category	1 <sup>(1)</sup>
Enclosure type	None (open-style)
North American temperature code	T4
IEC temperature code	T4
Reverse polarity protection	Yes

(1) Use this conductor category information for planning conductor routing as described in the system-level installation manual. See the Industrial Automation Wiring and Grounding Guidelines, publication [1770-4.1](#).

**Environmental Specifications - 1756-IB16I, 1756-IB16IK**

<b>Attribute</b>	<b>1756-IB16I, 1756-IB16IK</b>
Temperature, operating IEC 60068-2-1 (Test Ad, Operating Cold), IEC 60068-2-2 (Test Bd, Operating Dry Heat), IEC 60068-2-14 (Test Nb, Operating Thermal Shock)	0...60 °C (32...140 °F)
Temperature, surrounding air, max	60 °C (140 °F)
Temperature, nonoperating IEC 60068-2-1 (Test Ab, Unpackaged Nonoperating Cold), IEC 60068-2-2 (Test Bb, Unpackaged Nonoperating Dry Heat), IEC 60068-2-14 (Test Na, Unpackaged Nonoperating Thermal Shock)	-40...+85 °C (-40...+185 °F)
Relative humidity IEC 60068-2-30 (Test dB, Unpackaged Damp Heat)	5...95% noncondensing
Vibration IEC 60068-2-6 (Test Fc, Operating)	2 g @ 10...500 Hz
Shock, operating IEC 60068-2-27 (Test Ea, Unpackaged Shock)	30 g
Shock, nonoperating IEC 60068-2-27 (Test Ea, Unpackaged Shock)	50 g
Emissions	IEC 61000-6-4
ESD immunity IEC 61000-4-2	6 kV contact discharges 8 kV air discharges
Radiated RF immunity IEC 61000-4-3	10V/m with 1 kHz sine-wave 80% AM from 80...2000 MHz 10V/m with 200 Hz 50% Pulse 100% AM @ 900 MHz 10V/m with 200 Hz 50% Pulse 100% AM @ 1890 MHz 3V/m with 1 kHz sine-wave 80% AM from 2000...2700 MHz
EFT/B immunity IEC 61000-4-4	±4 kV at 5 kHz on signal ports
Surge transient immunity IEC 61000-4-5	±1 kV line-line (DM) and ±2 kV line-earth (CM) on signal ports
Conducted RF immunity IEC 61000-4-6	10V rms with 1 kHz sine-wave 80% AM from 150 kHz...80 MHz
Oscillatory surge withstand IEEE C37.90.1	3 kV

**Certifications - 1756-IB16I, 1756-IB16IK**

<b>Certification (when product is marked)<sup>(1)</sup></b>	<b>1756-IB16I, 1756-IB16IK</b>
UL	UL Listed Industrial Control Equipment. See UL File E65584.
CSA	CSA Certified Process Control Equipment. See CSA File LR54689C. CSA Certified Process Control Equipment for Class I, Division 2 Group A,B,C,D Hazardous Locations. See CSA File LR69960C.
CE	European Union 2014/30/EU EMC Directive, compliant with: <ul style="list-style-type: none"> <li>• EN 61326-1; Meas./Control/Lab., Industrial Requirements</li> <li>• EN 61000-6-2; Industrial Immunity</li> <li>• EN 61000-6-4; Industrial Emissions</li> <li>• EN 61131-2; Programmable Controllers (Clause 8, Zone A &amp; B)</li> </ul> European Union 2014/35/EU LVD, compliant with: EN 61131-2; Programmable Controllers (Clause 11)
RCM	Australian Radiocommunications Act, compliant with: EN 61000-6-4; Industrial Emissions
Ex	European Union 2014/34/EU ATEX Directive, compliant with: <ul style="list-style-type: none"> <li>• EN 60079-15; Potentially Explosive Atmospheres, Protection "n"</li> <li>• EN 60079-0; General Requirements II 3 G Ex nA IIC T4 X Gc</li> </ul>
FM	FM Approved Equipment for use in Class I Division 2 Group A,B,C,D Hazardous Locations
KC	Korean Registration of Broadcasting and Communications Equipment, compliant with: Article 58-2 of Radio Waves Act, Clause 3
EAC	Russian Customs Union TR CU 020/2011 EMC Technical Regulation Russian Customs Union TR CU 004/2011 LV Technical Regulation

(1) See the Product Certification link at [rok.auto/certifications](http://rok.auto/certifications) for Declarations of Conformity, Certificates, and other certification details.

## 1756-IB16IF, 1756-IB16IFK

ControlLogix DC (10...30V) sinking or sourcing, isolated, fast input module

Simplified Schematic

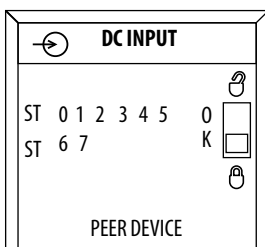
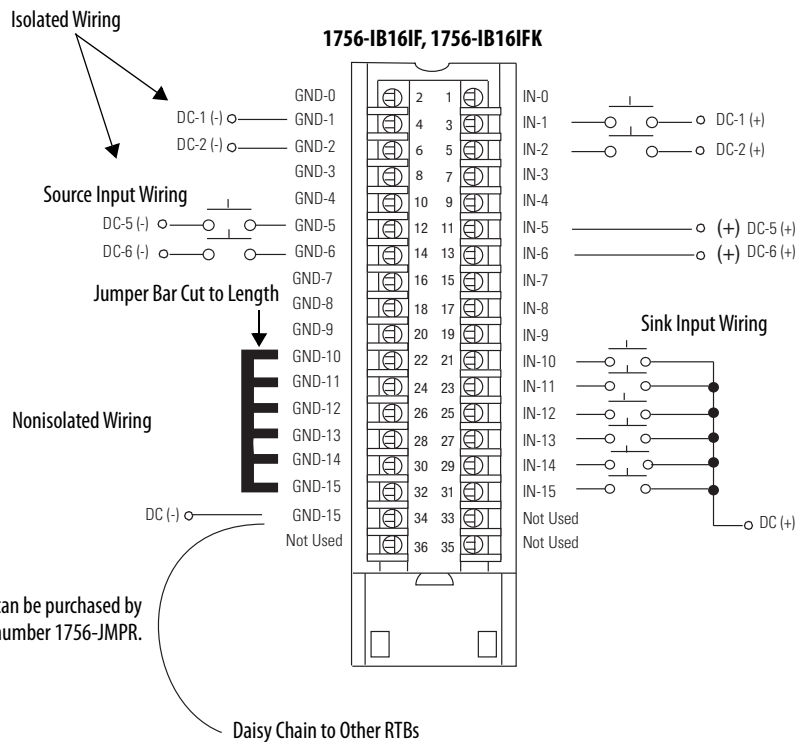
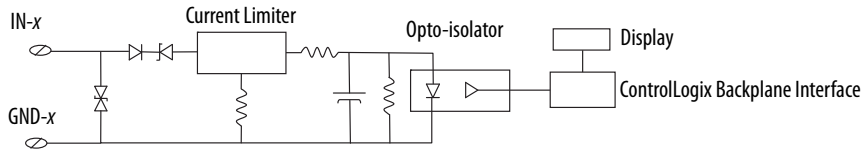

### Technical Specifications - 1756-IB16IF, 1756-IB16IFK

Attribute	1756-IB16IF, 1756-IB16IFK
Inputs	16 individually isolated
Voltage category	12/24V DC sink/source
Operating voltage range	10...30V DC
Input voltage, nom	24V DC

**Technical Specifications - 1756-IB16IF, 1756-IB16IFK**

Attribute	1756-IB16IF, 1756-IB16IFK
Input delay time (screw to backplane)	
Off to On	14 $\mu$ s nom/23 $\mu$ s max + user-configurable filter time of 0...30,000 $\mu$ s
On to Off	14 $\mu$ s nom/23 $\mu$ s max + user-configurable filter time of 0...30,000 $\mu$ s
Current draw @ 5.1V	275 mA
Current draw @ 24V	3 mA
Total backplane power	1.47 W
Power dissipation	3.8 W @ 60 °C (140 °F)
Thermal dissipation	12.97 BTU/hr
Off-state voltage, max	5V
Off-state current, max	1.5 mA
On-state current, min	2 mA @ 10V DC
On-state current, max	5 mA @ 30V DC
Input impedance, max	6 k $\Omega$ @ 30V DC
Cyclic update time	200 $\mu$ s...750 ms
Change of state	Software configurable
Time stamp of inputs	$\pm$ 4 $\mu$ s for inputs < 4 kHz $\pm$ 13 $\mu$ s for inputs > 4 kHz
Isolation voltage	250V (continuous), reinforced insulation type, inputs-to-backplane 250V (continuous), basic insulation type, input-to-input
Module keying	Electronic, software configurable
Removable terminal block housing	1756-TBCH 1756-TBS6H
RTB keying	User-defined mechanical
Slot width	1
Wire category	1 on signal ports <sup>(1)</sup>
Enclosure type	None (open-style)
North American temperature code	T4A
IEC temperature code	T4
Reverse polarity protection	Yes

(1) Use this conductor category information for planning conductor routing as described in the system-level installation manual. See the Industrial Automation Wiring and Grounding Guidelines, publication [1770-4.1](#).

**Environmental Specifications - 1756-IB16IF, 1756-IB16IFK**

Attribute	1756-IB16IF, 1756-IB16IFK
Temperature, operating IEC 60068-2-1 (Test Ad, Operating Cold), IEC 60068-2-2 (Test Bd, Operating Dry Heat), IEC 60068-2-14 (Test Nb, Operating Thermal Shock)	0...60 °C (32...140 °F)
Temperature, surrounding air, max	60 °C (140 °F)
Temperature, nonoperating IEC 60068-2-1 (Test Ab, Unpackaged Nonoperating Cold), IEC 60068-2-2 (Test Bb, Unpackaged Nonoperating Dry Heat), IEC 60068-2-14 (Test Na, Unpackaged Nonoperating Thermal Shock)	-40...+85 °C (-40...+185 °F)

**Environmental Specifications - 1756-IB16IF, 1756-IB16IFK**

Attribute	1756-IB16IF, 1756-IB16IFK
Relative humidity IEC 60068-2-30 (Test dB, Unpackaged Damp Heat)	5...95% noncondensing
Vibration IEC 60068-2-6 (Test Fc, Operating)	2 g @ 10...500 Hz
Shock, operating IEC 60068-2-27 (Test Ea, Unpackaged Shock)	30 g
Shock, nonoperating IEC 60068-2-27 (Test Ea, Unpackaged Shock)	50 g
Emissions	IEC 61000-6-4
ESD immunity IEC 61000-4-2	6 kV contact discharges 8 kV air discharges
Radiated RF immunity IEC 61000-4-3	10V/m with 1 kHz sine-wave 80% AM from 80...2000 MHz 10V/m with 200 Hz 50% Pulse 100% AM @ 900 MHz 10V/m with 200 Hz 50% Pulse 100% AM @ 1890 MHz 3V/m with 1 kHz sine-wave 80% AM from 2000...2700 MHz
EFT/B immunity IEC 61000-4-4	±4 kV at 5 kHz on signal ports
Surge transient immunity IEC 61000-4-5	±1 kV line-line (DM) and ±2 kV line-earth (CM) on signal ports
Conducted RF immunity IEC 61000-4-6	10V rms with 1 kHz sine-wave 80% AM from 150 kHz...80 MHz

**Certifications - 1756-IB16IF, 1756-IB16IFK**

Certification (when product is marked) <sup>(1)</sup>	1756-IB16IF, 1756-IB16IFK
c-UL-us	UL Listed Industrial Control Equipment, certified for US and Canada. See UL File E65584. UL Listed for Class I, Division 2 Group A,B,C,D Hazardous Locations, certified for U.S. and Canada. See UL File E194810.
CE	European Union 2014/30/EU EMC Directive, compliant with: <ul style="list-style-type: none"> <li>EN 61326-1; Meas./Control/Lab., Industrial Requirements</li> <li>EN 61000-6-2; Industrial Immunity</li> <li>EN 61000-6-4; Industrial Emissions</li> <li>EN 61131-2; Programmable Controllers (Clause 8, Zone A &amp; B)</li> </ul> European Union 2014/35/EU LVD, compliant with: EN 61131-2; Programmable Controllers (Clause 11)
RCM	Australian Radiocommunications Act, compliant with: EN 61000-6-4; Industrial Emissions
Ex	European Union 2014/34/EU ATEX Directive, compliant with: <ul style="list-style-type: none"> <li>EN 60079-15; Potentially Explosive Atmospheres, Protection "n"</li> <li>EN 60079-0; General Requirements II 3 G Ex nA IIC T4 X Gc</li> </ul>
KC	Korean Registration of Broadcasting and Communications Equipment, compliant with: Article 58-2 of Radio Waves Act, Clause 3
EAC	Russian Customs Union TR CU 020/2011 EMC Technical Regulation Russian Customs Union TR CU 004/2011 LV Technical Regulation

(1) See the Product Certification link at [rok.auto/certifications](http://rok.auto/certifications) for Declarations of Conformity, Certificates, and other certification details.

## 1756-IB16ISOE, 1756-IB16ISOEK

### ControlLogix DC (10...55V) sequence of events input module

Simplified Schematic

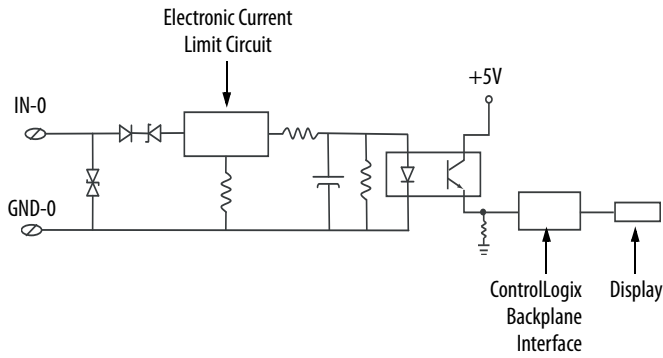

Additional jumper bars are available as catalog number 1756-JMPR.

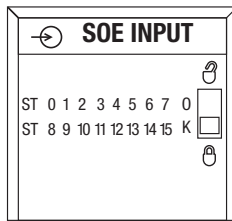

1756-IB16ISOE, 1756-IB16ISOEK

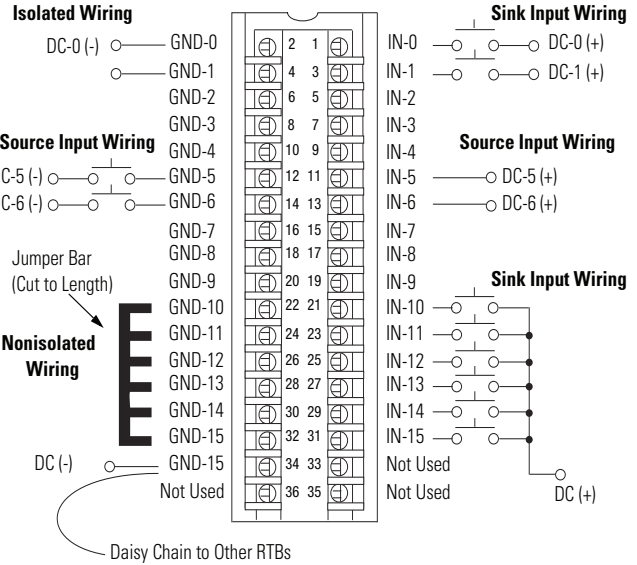

### Technical Specifications - 1756-IB16ISOE, 1756-IB16ISOEK

Attribute	1756-IB16ISOE, 1756-IB16ISOEK
Inputs	16 individually isolated, sequence of events
Voltage category	24/48V DC sink/source
Operating voltage range	10...55V DC
Input voltage, nom	24V DC
Input delay time (screw to backplane) Off to On	Hardware delay: 10 $\mu$ s nom/20 $\mu$ s max + firmware scan: up to 25 $\mu$ s + filter time: 0...50 ms + ASIC delay: 175 $\mu$ s (FIFO) or 625 $\mu$ s (Coordinated System Time per point)
On to Off	Hardware delay: 25 $\mu$ s nom/50 $\mu$ s max + firmware scan: up to 25 $\mu$ s + filter time: 0...50 ms + ASIC delay: 175 $\mu$ s (FIFO) or 625 $\mu$ s (Coordinated System Time per point)
Current draw @ 5.1V	320 mA
Current draw @ 24V	2 mA
Total backplane power	1.7 W
Power dissipation, max	5.5 W @ 60 °C (140 °F)

**Technical Specifications - 1756-IB16ISOE, 1756-IB16ISOEK**

Attribute	1756-IB16ISOE, 1756-IB16ISOEK
Thermal dissipation	17.22 BTU/hr
Off-state voltage, max	5V
Off-state current, max	1.5 mA
On-state current, min	2.0 mA @ 9V DC
On-state current, nom	4.5 mA @ 24...31V DC
On-state current, max	5.1 mA @ 48...55V DC
Input impedance, max	10.8 k $\Omega$ @ 55V DC
Cyclic update time	200 $\mu$ s...750 ms
Change of state	Software configurable
Time stamp of inputs	$\pm$ 100 $\mu$ s
Isolation voltage	250V (continuous), basic insulation type, inputs-to-backplane 125V (continuous), basic insulation type, input-to-input
Module keying	Electronic, software configurable
Removable terminal block	1756-TBCH 1756-TBS6H
RTB keying	User-defined mechanical
Slot width	1
Wire category	1 <sup>(1)</sup>
Enclosure type	None (open-style)
North American temperature code	T4
IEC temperature code	T4
Reverse polarity protection	Yes

(1) Use this conductor category information for planning conductor routing as described in the system-level installation manual. See the Industrial Automation Wiring and Grounding Guidelines, publication [1770-4.1](#).

**Environmental Specifications - 1756-IB16ISOE, 1756-IB16ISOEK**

Attribute	1756-IB16ISOE, 1756-IB16ISOEK
Temperature, operating IEC 60068-2-1 (Test Ad, Operating Cold), IEC 60068-2-2 (Test Bd, Operating Dry Heat), IEC 60068-2-14 (Test Nb, Operating Thermal Shock)	0...60 °C (32...140 °F)
Temperature, surrounding air, max	60 °C (140 °F)
Temperature, nonoperating IEC 60068-2-1 (Test Ab, Unpackaged Nonoperating Cold), IEC 60068-2-2 (Test Bb, Unpackaged Nonoperating Dry Heat), IEC 60068-2-14 (Test Na, Unpackaged Nonoperating Thermal Shock)	-40...+85 °C (-40...+185 °F)
Relative humidity IEC 60068-2-30 (Test dB, Unpackaged Damp Heat)	5...95% noncondensing
Vibration IEC 60068-2-6 (Test Fc, Operating)	2 g @ 10...500 Hz
Shock, operating IEC 60068-2-27 (Test Ea, Unpackaged Shock)	30 g
Shock, nonoperating IEC 60068-2-27 (Test Ea, Unpackaged Shock)	50 g
Emissions	IEC 61000-6-4



**Environmental Specifications - 1756-IB16ISOE, 1756-IB16ISOEK**

Attribute	1756-IB16ISOE, 1756-IB16ISOEK
ESD immunity IEC 61000-4-2	6 kV contact discharges 8 kV air discharges
Radiated RF immunity IEC 61000-4-3	10V/m with 1 kHz sine-wave 80% AM from 80...2000 MHz 10V/m with 200 Hz 50% Pulse 100% AM @ 900 MHz 10V/m with 200 Hz 50% Pulse 100% AM @ 1890 MHz 3V/m with 1 kHz sine-wave 80% AM from 2000...2700 MHz
EFT/B immunity IEC 61000-4-4	±4 kV at 5 kHz on signal ports
Surge transient immunity IEC 61000-4-5	±1 kV line-line (DM) and ±2 kV line-earth (CM) on signal ports
Conducted RF immunity IEC 61000-4-6	10V rms with 1 kHz sine-wave 80% AM from 150 kHz...80 MHz
Oscillatory surge withstand IEEE C37.90.1	2.5 kV

**Certifications - 1756-IB16ISOE, 1756-IB16ISOEK**

Certification (when product is marked) <sup>(1)</sup>	1756-IB16ISOE, 1756-IB16ISOEK
UL	UL Listed Industrial Control Equipment. See UL File E65584.
CSA	CSA Certified Process Control Equipment. See CSA File LR54689C. CSA Certified Process Control Equipment for Class I, Division 2 Group A,B,C,D Hazardous Locations. See CSA File LR69960C.
CE	European Union 2014/30/EU EMC Directive, compliant with: <ul style="list-style-type: none"> <li>EN 61326-1; Meas./Control/Lab., Industrial Requirements</li> <li>EN 61000-6-2; Industrial Immunity</li> <li>EN 61000-6-4; Industrial Emissions</li> <li>EN 61131-2; Programmable Controllers (Clause 8, Zone A &amp; B)</li> </ul> European Union 2014/35/EU LVD, compliant with: EN 61131-2; Programmable Controllers (Clause 11)
RCM	Australian Radiocommunications Act, compliant with: EN 61000-6-4; Industrial Emissions
Ex	European Union 2014/34/EU ATEX Directive, compliant with: <ul style="list-style-type: none"> <li>EN 60079-15; Potentially Explosive Atmospheres, Protection "n"</li> <li>EN 60079-0; General Requirements II 3 G Ex nA IIC T4 X Gc</li> </ul>
KC	Korean Registration of Broadcasting and Communications Equipment, compliant with: Article 58-2 of Radio Waves Act, Clause 3
EAC	Russian Customs Union TR CU 020/2011 EMC Technical Regulation Russian Customs Union TR CU 004/2011 LV Technical Regulation

(1) See the Product Certification link at [rok.auto/certifications](http://rok.auto/certifications) for Declarations of Conformity, Certificates, and other certification details.

## 1756-IB32, 1756-IB32K

ControlLogix DC (10...31.2V) input module

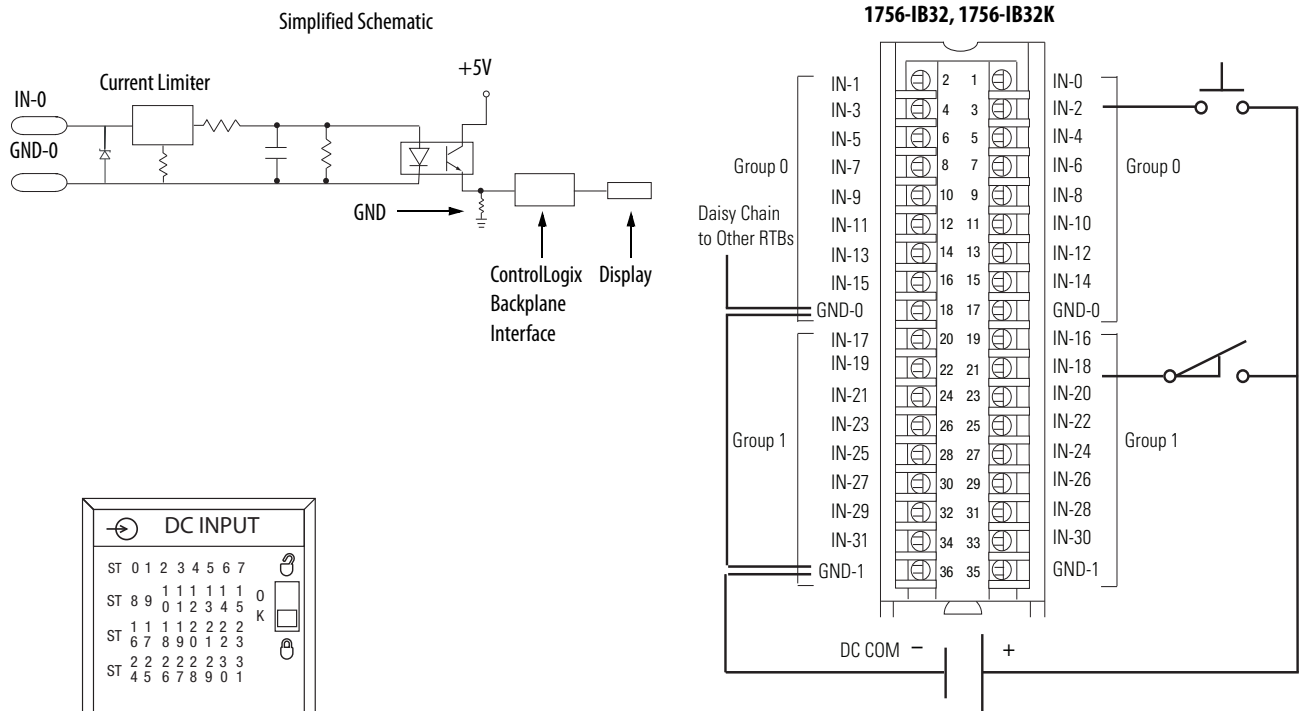

### Technical Specifications - 1756-IB32, 1756-IB32K

Attribute	1756-IB32, 1756-IB32K
Inputs	32 (16 points/group)
Voltage category	12/24V DC sink
Operating voltage range	10. . . 31.2V DC
Input voltage, nom	24V DC
Input delay time (screw to backplane)	Hardware delay: 380 $\mu$ s max + filter time User-selectable filter time: 0 ms, 1 ms, or 2 ms Hardware delay: 420 $\mu$ s max + filter time User-selectable filter time: 0 ms, 1 ms, 2 ms, 9 ms, or 18 ms
Off to On	
On to Off	
Current draw @ 5.1V	120 mA
Current draw @ 24V	2 mA
Total backplane power	0.66 W
Power dissipation, max	6.2 W @ 60 °C (140 °F)
Thermal dissipation	21.1 BTU/hr @ 60 °C (140 °F)
Off-state voltage, max	5V
Off-state current, max	2.27 mA
On-state current, min	4.8 mA @ 10V DC
On-state current, max	5.5 mA @ 31.2V DC

**Technical Specifications - 1756-IB32, 1756-IB32K**

Attribute	1756-IB32, 1756-IB32K
Inrush current, max	250 mA (decaying to < 37% in 22 ms, without activation)
Input impedance, max	5.67 k $\Omega$ @ 31.2V DC
Cyclic update time	200 $\mu$ s...750 ms
Change of state	Software configurable
Time stamp of inputs	$\pm$ 200 $\mu$ s
Isolation voltage	250V (continuous), reinforced insulation type, inputs-to-backplane 250V (continuous), basic insulation type, input group-to-group No isolation between individual group inputs
Module keying	Electronic, software configurable
Removable terminal block	1756-TBCH 1756-TBS6H
RTB keying	User-defined mechanical
Slot width	1
Wire category	1 - on signal ports <sup>(1)</sup>
Enclosure type	None (open-style)
North American temperature code	T4
IEC temperature code	T4
Reverse polarity protection	Yes

(1) Use this conductor category information for planning conductor routing as described in the system-level installation manual. See the Industrial Automation Wiring and Grounding Guidelines, publication [1770-4.1](#).

**Environmental Specifications - 1756-IB32, 1756-IB32K**

Attribute	1756-IB32, 1756-IB32K
Temperature, operating IEC 60068-2-1 (Test Ad, Operating Cold), IEC 60068-2-2 (Test Bd, Operating Dry Heat), IEC 60068-2-14 (Test Nb, Operating Thermal Shock)	0...60 °C (32...140 °F)
Temperature, surrounding air, max	60 °C (140 °F)
Temperature, nonoperating IEC 60068-2-1 (Test Ab, Unpackaged Nonoperating Cold), IEC 60068-2-2 (Test Bb, Unpackaged Nonoperating Dry Heat), IEC 60068-2-14 (Test Na, Unpackaged Nonoperating Thermal Shock)	-40...+85 °C (-40...+185 °F)
Relative humidity IEC 60068-2-30 (Test dB, Unpackaged Damp Heat)	5...95% noncondensing
Vibration IEC 60068-2-6 (Test Fc, Operating)	2 g @ 10...500 Hz
Shock, operating IEC 60068-2-27 (Test Ea, Unpackaged Shock)	30 g
Shock, nonoperating IEC 60068-2-27 (Test Ea, Unpackaged Shock)	50 g
Emissions	IEC 61000-6-4
ESD immunity IEC 61000-4-2	6 kV contact discharges 8 kV air discharges

**Environmental Specifications - 1756-IB32, 1756-IB32K**

Attribute	1756-IB32, 1756-IB32K
Radiated RF immunity IEC 61000-4-3	10V/m with 1 kHz sine-wave 80% AM from 80 . . .2000 MHz 10V/m with 200 Hz 50% Pulse 100% AM @ 900 MHz 10V/m with 200 Hz 50% Pulse 100% AM @ 1890 MHz 3V/m with 1 kHz sine-wave 80% AM from 2000 . . .2700 MHz
EFT/B immunity IEC 61000-4-4	±4 kV at 5 kHz on signal ports
Surge transient immunity IEC 61000-4-5	±1 kV line-line (DM) and ±2 kV line-earth (CM) on signal ports
Conducted RF immunity IEC 61000-4-6	10V rms with 1 kHz sine-wave 80% AM from 150 kHz . . .80 MHz
Oscillatory surge withstand IEEE C37.90.1	3 kV

**Certifications - 1756-IB32, 1756-IB32K**

Certification (when product is marked) <sup>(1)</sup>	1756-IB32, 1756-IB32K
c-UL-us	UL Listed Industrial Control Equipment, certified for US and Canada. See UL File E65584. UL Listed for Class I, Division 2 Group A,B,C,D Hazardous Locations, certified for U.S. and Canada. See UL File E194810.
CSA	CSA Certified Process Control Equipment. See CSA File LR54689C. CSA Certified Process Control Equipment for Class I, Division 2 Group A,B,C,D Hazardous Locations. See CSA File LR69960C.
CE	European Union 2014/30/EU EMC Directive, compliant with: <ul style="list-style-type: none"> <li>EN 61326-1; Meas./Control/Lab., Industrial Requirements</li> <li>EN 61000-6-2; Industrial Immunity</li> <li>EN 61000-6-4; Industrial Emissions</li> <li>EN 61131-2; Programmable Controllers (Clause 8, Zone A &amp; B)</li> </ul> European Union 2014/35/EU LVD, compliant with: EN 61131-2; Programmable Controllers (Clause 11)
RCM	Australian Radiocommunications Act, compliant with: EN 61000-6-4; Industrial Emissions
Ex	European Union 2014/34/EU ATEX Directive, compliant with: <ul style="list-style-type: none"> <li>EN 60079-15; Potentially Explosive Atmospheres, Protection "n"</li> <li>EN 60079-0; General Requirements II 3 G Ex nA IIC T4 X Gc</li> </ul>
FM	FM Approved Equipment for use in Class I Division 2 Group A,B,C,D Hazardous Locations
KC	Korean Registration of Broadcasting and Communications Equipment, compliant with: Article 58-2 of Radio Waves Act, Clause 3
EAC	Russian Customs Union TR CU 020/2011 EMC Technical Regulation Russian Customs Union TR CU 004/2011 LV Technical Regulation

(1) See the Product Certification link at [rok.auto/certifications](http://rok.auto/certifications) for Declarations of Conformity, Certificates, and other certification details.

## 1756-IC16

ControlLogix DC (30...60V) input module

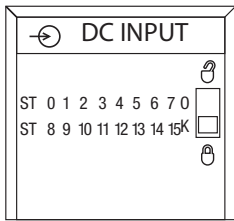
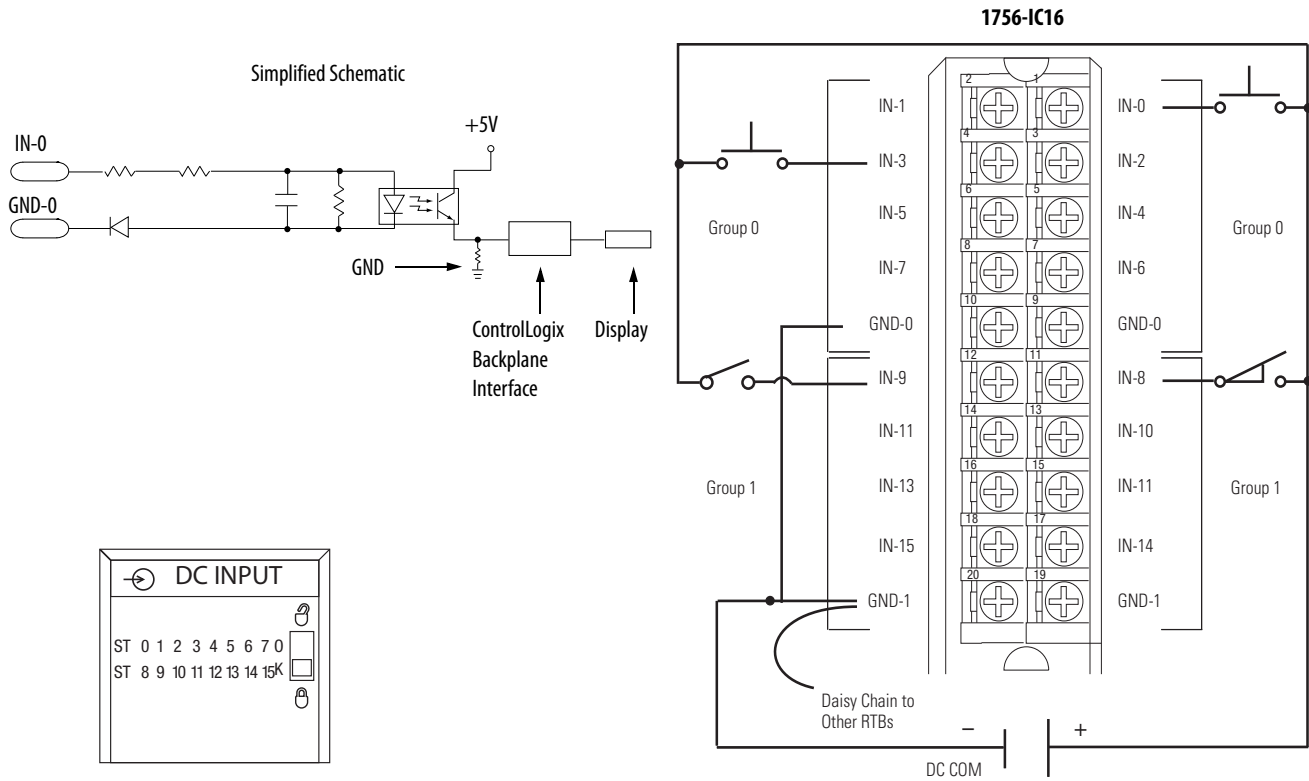

### Technical Specifications - 1756-IC16

Attribute	1756-IC16
Inputs	16 (8 points/group)
Voltage category	48V DC sink
Operating voltage range	30...55V DC @ 60 °C (140 °F) 30...60V DC @ 55 °C (131 °F)
Input voltage, nom	48V DC
Input delay time (screw to backplane)	Hardware delay: 1 ms max + filter time User-selectable filter time: 0 ms, 1 ms, or 2 ms Hardware delay: 4 ms max + filter time User-selectable filter time: 0 ms, 1 ms, 2 ms, 9 ms, or 18 ms
Off to On	
On to Off	
Current draw @ 5.1V	100 mA
Current draw @ 24V	3 mA
Total backplane power	0.58 W
Power dissipation, max	5.2 W @ 60 °C (140 °F)
Thermal dissipation	17.73 BTU/hr
Off-state voltage, max	10V
Off-state current, max	1.5 mA
On-state current, min	2 mA @ 30V DC

**Technical Specifications - 1756-IC16 (continued)**

Attribute	1756-IC16
On-state current, max	7 mA @ 60V DC
Inrush current, max	250 mA
Input impedance, max	8.57 k $\Omega$ @ 60V DC
Cyclic update time	200 $\mu$ s...750 ms
Change of state	Software configurable
Time stamp of inputs	$\pm$ 200 $\mu$ s
Isolation voltage	250V (continuous), basic insulation type, inputs-to-backplane 125V (continuous), basic insulation type, input group-to-group No isolation between individual group inputs
Module keying	Electronic, software configurable
Removable terminal block housing	1756-TBNH 1756-TBSH
RTB keying	User-defined mechanical
Slot width	1
Wire category	1 <sup>(1)</sup>
Enclosure type	None (open-style)
North American temperature code	T4
IEC temperature code	T4
Reverse polarity protection	Yes

(1) Use this conductor category information for planning conductor routing as described in the system-level installation manual. See the Industrial Automation Wiring and Grounding Guidelines, publication [1770-4.1](#).

**Environmental Specifications - 1756-IC16**

Attribute	1756-IC16
Temperature, operating IEC 60068-2-1 (Test Ad, Operating Cold), IEC 60068-2-2 (Test Bd, Operating Dry Heat), IEC 60068-2-14 (Test Nb, Operating Thermal Shock)	0...60 °C (32...140 °F)
Temperature, surrounding air, max	60 °C (140 °F)
Temperature, nonoperating IEC 60068-2-1 (Test Ab, Unpackaged Nonoperating Cold), IEC 60068-2-2 (Test Bb, Unpackaged Nonoperating Dry Heat), IEC 60068-2-14 (Test Na, Unpackaged Nonoperating Thermal Shock)	-40...+85 °C (-40...+185 °F)
Relative humidity IEC 60068-2-30 (Test dB, Unpackaged Damp Heat)	5...95% noncondensing
Vibration IEC 60068-2-6 (Test Fc, Operating)	2 g @ 10...500 Hz
Shock, operating IEC 60068-2-27 (Test Ea, Unpackaged Shock)	30 g
Shock, nonoperating IEC 60068-2-27 (Test Ea, Unpackaged Shock)	50 g
Emissions	IEC 61000-6-4
ESD immunity IEC 61000-4-2	6 kV contact discharges 8 kV air discharges

**Environmental Specifications - 1756-IC16 (continued)**

Attribute	1756-IC16
Radiated RF immunity IEC 61000-4-3	10V/m with 1 kHz sine-wave 80% AM from 80. . .2000 MHz 10V/m with 200 Hz 50% Pulse 100% AM @ 900 MHz 10V/m with 200 Hz 50% Pulse 100% AM @ 1890 MHz 3V/m with 1 kHz sine-wave 80% AM from 2000. . .2700 MHz
EFT/B immunity IEC 61000-4-4	±4 kV at 5 kHz on signal ports
Surge transient immunity IEC 61000-4-5	±1 kV line-line (DM) and ± 2 kV line-earth (CM) on signal ports
Conducted RF immunity IEC 61000-4-6	10V rms with 1 kHz sine-wave 80% AM from 150 kHz. . .80 MHz
Oscillatory surge withstand IEEE C37.90.1	3 kV

**Certifications - 1756-IC16**

Certification (when product is marked) <sup>(1)</sup>	1756-IC16
UL	UL Listed Industrial Control Equipment. See UL File E65584.
CSA	CSA Certified Process Control Equipment. See CSA File LR54689C. CSA Certified Process Control Equipment for Class I, Division 2 Group A,B,C,D Hazardous Locations. See CSA File LR69960C.
CE	European Union 2014/30/EU EMC Directive, compliant with: <ul style="list-style-type: none"> <li>EN 61326-1; Meas./Control/Lab., Industrial Requirements</li> <li>EN 61000-6-2; Industrial Immunity</li> <li>EN 61000-6-4; Industrial Emissions</li> <li>EN 61131-2; Programmable Controllers (Clause 8, Zone A &amp; B)</li> </ul> European Union 2014/35/EU LVD, compliant with: EN 61131-2; Programmable Controllers (Clause 11)
RCM	Australian Radiocommunications Act, compliant with: EN 61000-6-4; Industrial Emissions
Ex	European Union 2014/34/EU ATEX Directive, compliant with: <ul style="list-style-type: none"> <li>EN 60079-15; Potentially Explosive Atmospheres, Protection "n"</li> <li>EN 60079-0; General Requirements II 3 G Ex nA IICT4 X Gc</li> </ul>
FM	FM Approved Equipment for use in Class I Division 2 Group A,B,C,D Hazardous Locations
KC	Korean Registration of Broadcasting and Communications Equipment, compliant with: Article 58-2 of Radio Waves Act, Clause 3
EAC	Russian Customs Union TR CU 020/2011 EMC Technical Regulation Russian Customs Union TR CU 004/2011 LV Technical Regulation

(1) See the Product Certification link at [rok.auto/certifications](http://rok.auto/certifications) for Declarations of Conformity, Certificates, and other certification details.

## 1756-IF4FXOF2F, 1756-IF4FXOF2FK

ControlLogix high-speed input/output analog module

**1756-IF4FXOF2F, 1756-IF4FXOF2FK Current**

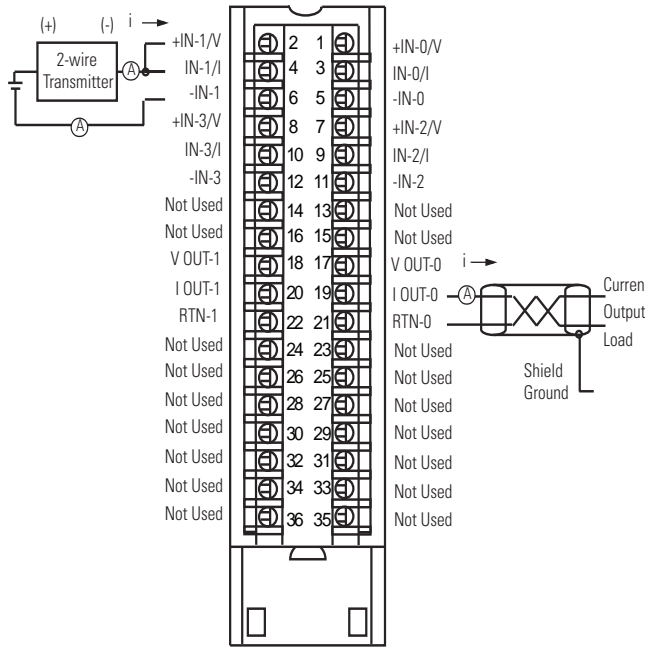

A = Inline field device (such as a strip chart recorder or meter)

**1756-IF4FXOF2F, 1756-IF4FXOF2FK Voltage**

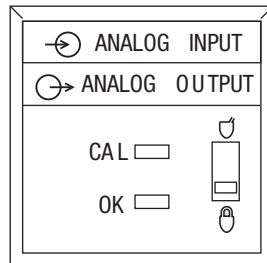
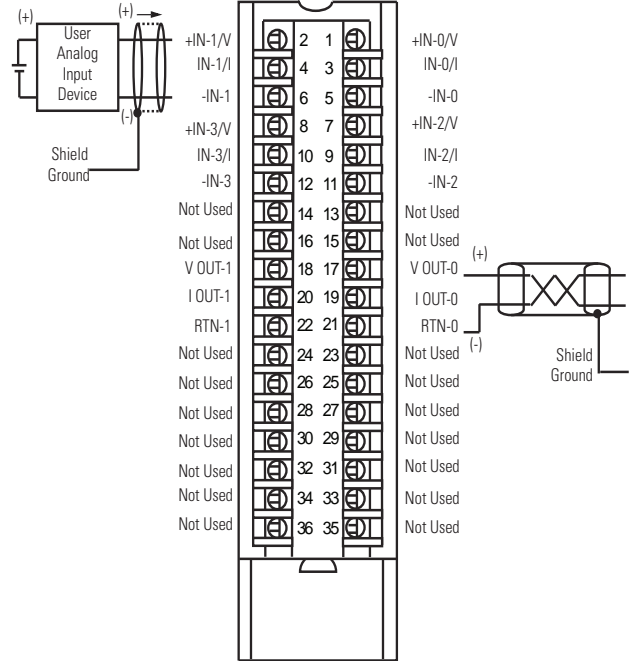

### Technical Specifications - 1756-IF4FXOF2F, 1756-IF4FXOF2FK

Attribute	1756-IF4FXOF2F, 1756-IF4FXOF2FK
Current draw at 5.1V	375 mA
Current draw at 24V	100 mA
Voltage and current ratings	Backplane: 375 mA @ 5.1V DC, 100 mA @ 24V DC Analog inputs: -10...+10V, 4...20 mA Analog outputs: -10...+10V, 4...20 mA
Power consumption	4.3 W
Power dissipation	Voltage: 4.3 W Current: 4.7 W
Thermal dissipation	Voltage: 14.66 BTU/hr Current: 16.02 BTU/hr
Data format	Integer mode (left justified, 2 s complement) IEEE 32-bit floating point



**Technical Specifications - 1756-IF4FXOF2F, 1756-IF4FXOF2FK**

Attribute	1756-IF4FXOF2F, 1756-IF4FXOF2FK
Isolation voltage	250V (continuous) Reinforced insulation type, inputs and outputs to backplane No isolation between individual inputs or outputs
Module keying	Electronic, software configurable
Removable terminal block	1756-TBCH 1756-TBS6H
RTB keying	User-defined mechanical
Slot width	1
Wire size	1756-TBCH Single wire connection: 0.33...2.1 mm <sup>2</sup> (22...14 AWG) solid or stranded shielded copper wire rated at 105 °C (221 °F), or greater, 1.2 mm (3/64 in.) insulation max  1756-TBS6H Single wire connection: 0.33...2.1 mm <sup>2</sup> (22...14 AWG) solid or stranded shielded copper wire rated at 105 °C (221 °F), or greater, 1.2 mm (3/64 in.) insulation max
Terminal block torque specs	1756-TBCH: 0.5 Nm (4.4 pound-inches)
Wiring category <sup>(1)</sup>	2 - on signal ports
Enclosure type	None (open-style)
North American temp code	T4A
ATEX temp code	T4
IECEx temperature code	T4

(1) Use this Conductor Category information for planning conductor routing. See the Industrial Automation Wiring and Grounding Guidelines, publication [1770-4.1](#).

**Input Specifications - 1756-IF4FXOF2F, 1756-IF4FXOF2FK**

Attribute	1756-IF4FXOF2F, 1756-IF4FXOF2FK
Number	4 high-speed, submillisecond, differential
Input range	± 10V 0...10V 0...5V 0...20 mA (Ovrange indication when exceeded)
Resolution	Approx 14 bits across ±10.5V DC (21V total) ±10.5V range: 1.3 mV/bit, 14 bit effective 0...10.5V range: 1.3 mV/bit, 13 bit effective 0...5.25V range: 1.3 mV/bit, 12 bit effective Approx 12 bits across 21 mA 0...21 mA range: 5.25 µA/bit
Repeatability	±1 Least Significant Bit (LSB) <sup>(1)</sup>
Input impedance	Voltage: >1 MΩ Current: 249 Ω
Open circuit detection	Positive full-scale reading within 1 s
Ovoltage protection	Voltage: 30V DC Current: 8V AC/DC
Calibrated accuracy @ 25 °C (77 °F)	0.05% of range immediately after calibration Better than 0.1% of range within calibration interval
Calibration interval	12 months

**Input Specifications - 1756-IF4FXOF2F, 1756-IF4FXOF2FK**

Attribute	1756-IF4FXOF2F, 1756-IF4FXOF2FK
Gain drift with temperature	Voltage: 25 ppm/°C max Current: 35 ppm/°C max
Module error	0.2% of range
Module scan time	300 $\mu$ s min <sup>(2)</sup>
Input conversion method	Successive approximation

(1) Repeatability is defined as the stability of the input channel reading when a steady state signal is applied, for example,  $\pm 1$  LSB is one count (1.3 mV) from the nominal reading.

(2) 300  $\mu$ s min for 1756-IF4FXOF2F/B, firmware revision 3.x or greater. 400  $\mu$ s min for 1756-IF4FXOF2F/A, firmware revision 1.x.

**Output Specifications - 1756-IF4FXOF2F, 1756-IF4FXOF2FK**

Attribute	1756-IF4FXOF2F, 1756-IF4FXOF2FK
Number	Two high-speed voltage or current
Output range	$\pm 10$ V 0...20 mA
Resolution	13 bits across 21 mA = 2.8 $\mu$ A/bit 14 bits across 21.8V = 1.3 mV/bit
Open circuit detection	Current output only (Output must be set to >0.1 mA)
Overvoltage protection	24V DC
Short circuit protection	Electronically current limited to 21 mA or less
Drive capability	Voltage: >2000 $\Omega$ Current: 0...750 $\Omega$
Output settling time	< 2 ms to 95% of final value with resistive loads
Calibrated accuracy @ 25 °C (77 °F)	0.05% of range immediately after calibration Better than 0.1% of range within calibration interval
Calibration interval	12 months
Offset drift	50 $\mu$ V/°C 1 $\mu$ A/°C
Gain drift with temperature	Voltage: 25 ppm/°C max Current: 50 ppm/°C max
Module error	Voltage: 0.2% of range Current: 0.3% of range
Update period for all channels (RPI), min	1 ms
Output conversion method	R-Ladder DAC, monotonicity with no missing codes

**Environmental Specifications - 1756-IF4FXOF2F, 1756-IF4FXOF2FK**

Attribute	1756-IF4FXOF2F, 1756-IF4FXOF2FK
Temperature, operating IEC 60068-2-1 (Test Ad, Operating Cold), IEC 60068-2-2 (Test Bd, Operating Dry Heat), IEC 60068-2-14 (Test Nb, Operating Thermal Shock)	0 °C < Ta < +60 °C (+32 °F < Ta < +140 °F)
Temperature, surrounding air, max	60 °C (140 °F)
Temperature, nonoperating IEC 60068-2-1 (Test Ab, Unpackaged Nonoperating Cold), IEC 60068-2-2 (Test Bb, Unpackaged Nonoperating Dry Heat), IEC 60068-2-14 (Test Na, Unpackaged Nonoperating Thermal Shock)	-40...+85 °C (-40...+185 °F)
Relative humidity IEC 60068-2-30 (Test dB, Unpackaged Damp Heat)	5...95% noncondensing

**Environmental Specifications - 1756-IF4FXOF2F, 1756-IF4FXOF2FK**

Attribute	1756-IF4FXOF2F, 1756-IF4FXOF2FK
Vibration IEC 60068-2-6 (Test Fc, Operating)	2 g @ 10...500 Hz
Shock, operating IEC 60068-2-27 (Test Ea, Unpackaged Shock)	30 g
Shock, nonoperating IEC 60068-2-27 (Test Ea, Unpackaged Shock)	50 g
Emissions	IEC 61000-6-4
ESD immunity IEC 61000-4-2	6 kV contact discharges 8 kV air discharges
Radiated RF immunity IEC 61000-4-3	10V/m with 1 kHz sine-wave 80% AM from 80...2000 MHz 10V/m with 200 Hz 50% Pulse 100% AM @ 900 MHz 10V/m with 200 Hz 50% Pulse 100% AM @ 1890 MHz 3V/m with 1 kHz sine-wave 80% AM from 2000...2700 MHz 3V/m with 1 kHz sine-wave 80% AM from 2700...6000 MHz
EFT/B immunity IEC 61000-4-4	±2 kV at 5 kHz and 100 kHz on shielded signal ports
Surge transient immunity IEC 61000-4-5	±2 kV line-earth (CM) on shielded signal ports
Conducted RF immunity IEC 61000-4-6	10V rms with 1 kHz sine-wave 80% AM from 150 kHz...80 MHz

**Certifications - 1756-IF4FXOF2F, 1756-IF4FXOF2FK**

Certification (when product is marked) <sup>(1)</sup>	1756-IF4FXOF2F, 1756-IF4FXOF2FK
UL	UL Listed Industrial Control Equipment. See UL File E65584.
CSA	CSA Certified Process Control Equipment for Class I, Division 2 Group A,B,C,D Hazardous Locations. See CSA File LR69960C.
FM	FM Approved Equipment for use in Class I Division 2 Group A,B,C,D Hazardous Locations
CE	European Union 2014/30/EU EMC Directive, compliant with: <ul style="list-style-type: none"> <li>EN 61326-1; Meas./Control/Lab., Industrial Requirements</li> <li>EN 61000-6-2; Industrial Immunity</li> <li>EN 61000-6-4; Industrial Emissions</li> <li>EN 61131-2; Programmable Controllers (Clause 8, Zone A &amp; B)</li> </ul> European Union 2014/35/EU LVD, compliant with: EN 61131-2; Programmable Controllers (Clause 11)
RCM	Australian Radiocommunications Act, compliant with: EN 61000-6-4; Industrial Emissions
Ex	European Union 2014/34/EU ATEX Directive, compliant with: <ul style="list-style-type: none"> <li>EN 60079-0; General Requirements</li> <li>EN 60079-15; Potentially Explosive Atmospheres, Protection "n"</li> <li>II 3 G Ex nA IIC T4 Gc</li> <li>DEMKO15ATEX1482X</li> </ul>
IECEX	IECEX System, compliant with: <ul style="list-style-type: none"> <li>IEC 60079-0; General Requirements</li> <li>IEC 60079-15; Potentially Explosive Atmospheres, Protection "n"</li> <li>II 3 G Ex nA IIC T4 Gc</li> <li>IECEX UL 15.0053X</li> </ul>
KC	Korean Registration of Broadcasting and Communications Equipment, compliant with: Article 58-2 of Radio Waves Act, Clause 3
EAC	Russian Customs Union TR CU 020/2011 EMC Technical Regulation Russian Customs Union TR CU 004/2011 LV Technical Regulation

(1) See the Product Certification link at [rok.auto/certifications](http://rok.auto/certifications) for Declarations of Conformity, Certificates, and other certification details.

## 1756-IF6CIS

### ControlLogix sourcing current loop analog input module

1756-IF6CIS 2-wire Transmitter Connected to the Module and the Module Providing 24V DC Loop Power

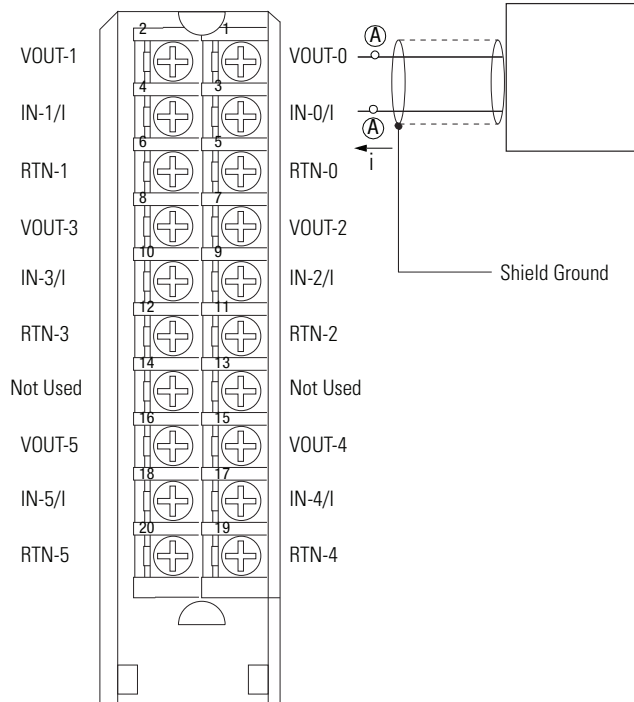

1756-IF6CIS 2-wire Transmitter Connected to the Module and an External, User-provided Power Supply Providing 24V DC Loop Power

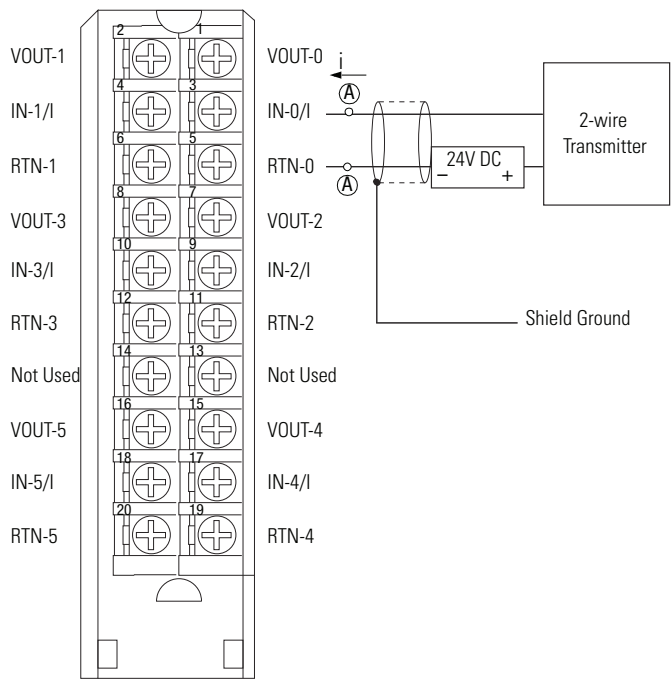

Place additional loop devices (such as strip chart recorders) at either A location in the current loop.

1756-IF6CIS 4-wire Transmitter Connected to the Module and an External, User-provided Power Supply Providing 24V DC Loop Power

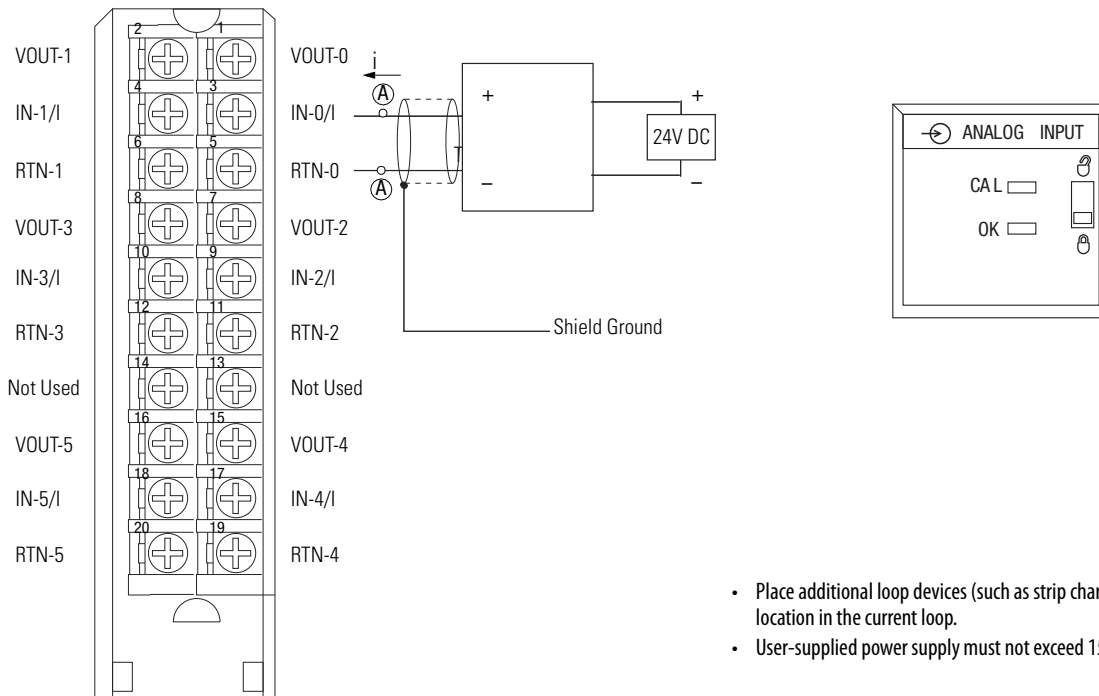

- Place additional loop devices (such as strip chart recorders) at either A location in the current loop.
- User-supplied power supply must not exceed 150VA.

**Signal and User Counts - 1756-IF6CIS**

Range	Low Signal and User Counts	High Signal and User Counts
0...20 mA	0 mA -32768 counts	21.09376 mA 32767 counts

**Technical Specifications - 1756-IF6CIS**

Attribute	1756-IF6CIS
Inputs	6 individually isolated current sourcing
Input range	0...20 mA (overrange indication when exceeded)
Resolution	16 bits 0.34 $\mu$ A/bit
Current draw @ 5.1V	250 mA
Current draw @ 24V	275 mA
Total backplane power	7.9 W
Power dissipation, max	5.1 W @ 60 °C (140 °F)
Thermal dissipation	17.4 BTU/hr
Input impedance	215 $\Omega$ , approx
Sourcing voltage, min	20V DC
Sourcing voltage, max	30V DC
Sourcing current, max	Current limited to < 30 mA
Open circuit detection time	Zero reading within 5 s
Overvoltage protection, max	30V AC/DC with PTC and sense resistor
Normal mode noise rejection	60 dB @ 60 Hz <sup>(1)</sup>
Common mode noise rejection	120 dB @ 60 Hz 100 dB @ 50 Hz
Channel bandwidth	3...262 Hz (-3 dB) <sup>(1)</sup>
Settling time	<80 ms to 5% of full scale <sup>(1)</sup>
Calibrated accuracy 25 °C (77 °F), nom	Better than 0.1% of range
Calibrated accuracy 25 °C (77 °F), max	0.025% of range
Calibration interval	12 months
Offset drift	200 nA/°C
Gain drift with temperature, nom	17 ppm/°C 0.36 $\mu$ A/°C
Gain drift with temperature, max	35 ppm/°C max 0.74 $\mu$ A/°C max
Module error	0.2% of range
Module input scan time, min	25 ms min – floating point 10 ms min – integer
Onboard data alarming	Yes
Scaling to engineering units	Yes
Real-time channel sampling	Yes
Data format	Integer mode (left justified, 2 s complement) IEEE 32-bit floating point
Module conversion method	Sigma-Delta

**Technical Specifications - 1756-IF6CIS (continued)**

Attribute	1756-IF6CIS
Isolation voltage	250V (continuous), basic insulation type, input channels-to-backplane, and input channel-to-channel
Module keying	Electronic, software configurable
Removable terminal block	1756-TBNH 1756-TBSH
RTB keying	User-defined mechanical
Slot width	1
Wire category	2 <sup>(2)</sup>
Enclosure type	None (open-style)
North American temperature code	T4A
IEC temperature code	T4

(1) Notch filter dependent.

(2) Use this conductor category information for planning conductor routing as described in the system-level installation manual. See the Industrial Automation Wiring and Grounding Guidelines, publication [1770-4.1](#).

**Environmental Specifications - 1756-IF6CIS**

Attribute	1756-IF6CIS
Temperature, operating IEC 60068-2-1 (Test Ad, Operating Cold), IEC 60068-2-2 (Test Bd, Operating Dry Heat), IEC 60068-2-14 (Test Nb, Operating Thermal Shock)	0...60 °C (32...140 °F)
Temperature, surrounding air, max	60 °C (140 °F)
Temperature, nonoperating IEC 60068-2-1 (Test Ab, Unpackaged Nonoperating Cold), IEC 60068-2-2 (Test Bb, Unpackaged Nonoperating Dry Heat), IEC 60068-2-14 (Test Na, Unpackaged Nonoperating Thermal Shock)	-40...+85 °C (-40...+185 °F)
Relative humidity IEC 60068-2-30 (Test dB, Unpackaged Damp Heat)	5...95% noncondensing
Vibration IEC 60068-2-6 (Test Fc, Operating)	2 g @ 10...500 Hz
Shock, operating IEC 60068-2-27 (Test Ea, Unpackaged Shock)	30 g
Shock, nonoperating IEC 60068-2-27 (Test Ea, Unpackaged Shock)	50 g
Emissions	IEC 61000-6-4
ESD immunity IEC 61000-4-2	6 kV contact discharges 8 kV air discharges
Radiated RF immunity IEC 61000-4-3	10V/m with 1 kHz sine-wave 80% AM from 80...2000 MHz 10V/m with 200 Hz 50% Pulse 100% AM @ 900 MHz 10V/m with 200 Hz 50% Pulse 100% AM @ 1890 MHz 3V/m with 1 kHz sine-wave 80% AM from 2000...2700 MHz
EFT/B immunity IEC 61000-4-4	±2 kV at 5 kHz on shielded signal ports
Surge transient immunity IEC 61000-4-5	±2 kV line-earth (CM) on shielded signal ports
Conducted RF immunity IEC 61000-4-6	10V rms with 1 kHz sine-wave 80% AM from 150 kHz...80 MHz on shielded signal ports

**Certifications - 1756-IF6CIS**

<b>Certification (when product is marked)<sup>(1)</sup></b>	<b>1756-IF6CIS</b>
UL	UL Listed Industrial Control Equipment. See UL File E65584.
CSA	CSA Certified Process Control Equipment. See CSA File LR54689C. CSA Certified Process Control Equipment for Class I, Division 2 Group A,B,C,D Hazardous Locations. See CSA File LR69960C.
CE	European Union 2014/30/EU EMC Directive, compliant with: <ul style="list-style-type: none"> <li>• EN 61326-1; Meas./Control/Lab., Industrial Requirements</li> <li>• EN 61000-6-2; Industrial Immunity</li> <li>• EN 61000-6-4; Industrial Emissions</li> <li>• EN 61131-2; Programmable Controllers (Clause 8, Zone A &amp; B)</li> </ul> European Union 2014/35/EU LVD, compliant with: EN 61131-2; Programmable Controllers (Clause 11)
RCM	Australian Radiocommunications Act, compliant with: EN 61000-6-4; Industrial Emissions
Ex	European Union 2014/34/EU ATEX Directive, compliant with: <ul style="list-style-type: none"> <li>• EN 60079-15; Potentially Explosive Atmospheres, Protection "n"</li> <li>• EN 60079-0; General Requirements II 3 G Ex nA IIC T4 X Gc</li> </ul>
FM	FM Approved Equipment for use in Class I Division 2 Group A,B,C,D Hazardous Locations
KC	Korean Registration of Broadcasting and Communications Equipment, compliant with: Article 58-2 of Radio Waves Act, Clause 3
EAC	Russian Customs Union TR CU 020/2011 EMC Technical Regulation Russian Customs Union TR CU 004/2011 LV Technical Regulation

(1) See the Product Certification link at [rok.auto/certifications](http://rok.auto/certifications) for Declarations of Conformity, Certificates, and other certification details.

# 1756-IF6I

## ControlLogix isolated voltage/current analog input module

### 1756-IF6I Current 2-wire

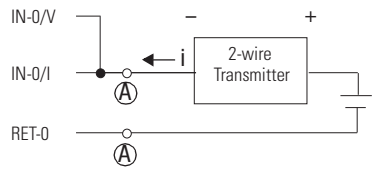
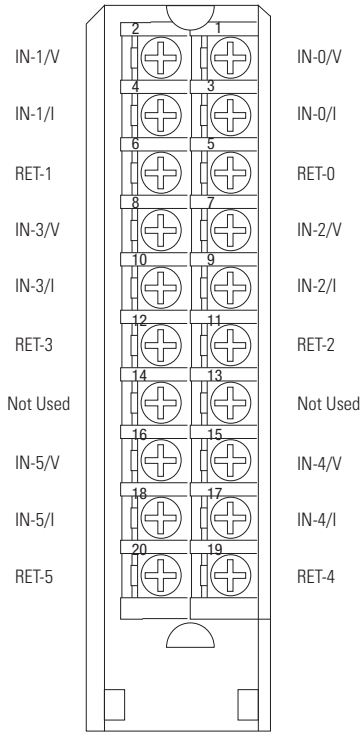

### 1756-IF6I Current 4-wire

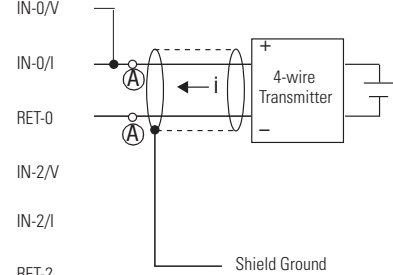
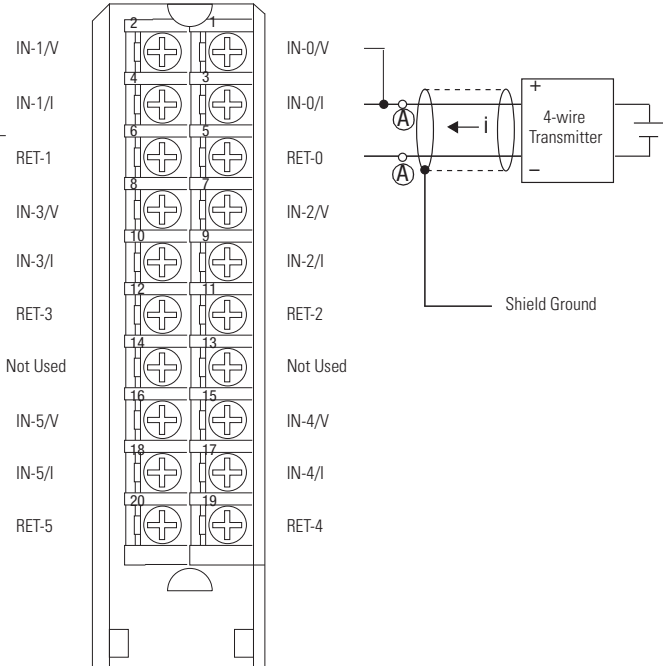

Place additional loop devices (such as strip chart recorders) at either A location.

### 1756-IF6I Voltage

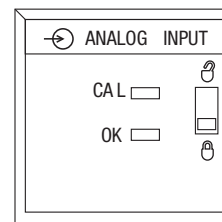
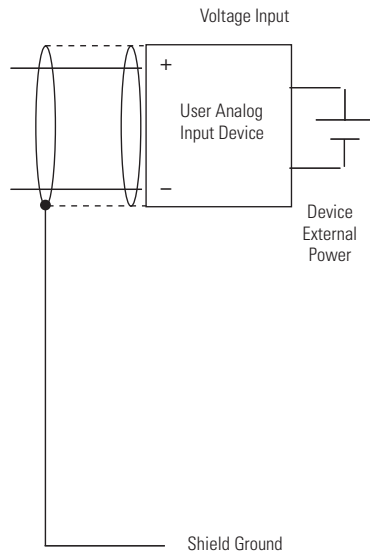
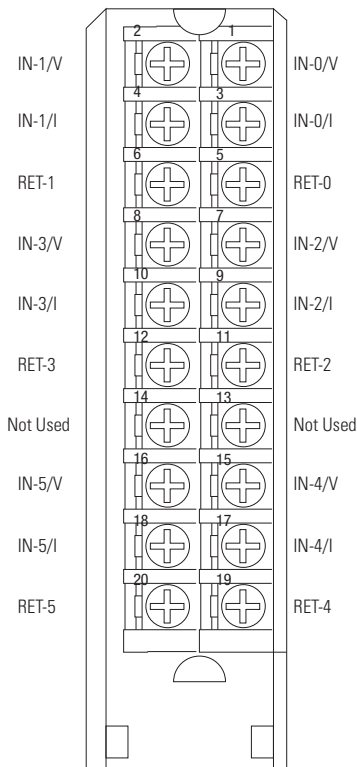



**Signal and User Counts - 1756-IF6I**

Range	Low Signal and User Counts	High Signal and User Counts
±10V	-10.54688V -32768 counts	10.54688V 32767 counts
0...10V	0V -32768 counts	10.54688V 32767 counts
0...5V	0V -32768 counts	5.27344V 32767 counts
0...20 mA	0 mA -32768 counts	21.09376V 32767 counts

**Technical Specifications - 1756-IF6I**

Attribute	1756-IF6I
Inputs	6 individually isolated
Input range	±10.5V 0...10.5V 0...5.25V 0...21 mA (Overrange indication when exceeded)
Resolution	16 bits 10.5V: 343 $\mu$ V/bit 0...10.5V: 171 $\mu$ V/bit 0...5.25V: 86 $\mu$ V/bit 0...21 mA: 0.34 $\mu$ A/bit
Current draw @ 5.1V	250 mA
Current draw @ 24V	100 mA
Total backplane power	3.7 W
Power dissipation, max	Voltage: 3.7 W Current: 4.3 W
Thermal dissipation	Voltage: 12.62 BTU/hr Current: 14.32 BTU/hr
Input impedance	Voltage: > 10 M $\Omega$ Current: 249 $\Omega$
Open circuit detection time	Positive full scale reading within 5 s
Overvoltage protection, max	Voltage: 120V AC/DC Current: 8V AC/DC (with onboard current resistor)
Normal mode noise rejection	60 dB @ 60 Hz <sup>(1)</sup>
Common mode noise rejection	120 dB @ 60 Hz 100 dB @ 50 Hz
Channel bandwidth	15 Hz (-3 dB) <sup>(1)</sup>
Settling time	<80 ms to 5% of full scale <sup>(1)</sup>
Calibrated accuracy 25 °C (77 °F)	Better than 0.1% of range
Calibration interval	6 months
Offset drift	2 $\mu$ V/°C
Gain drift with temperature	Voltage: 35 ppm/°C, 80 ppm/°C max Current: 45 ppm/°C, 90 ppm/°C max
Module error	0.54% of range

**Technical Specifications - 1756-IF6I (continued)**

Attribute	1756-IF6I
Module input scan time, min	25 ms min – floating point 10 ms min – integer <sup>(1)</sup>
Onboard data alarming	Yes
Scaling to engineering units	Yes
Real-time channel sampling	Yes
Data format	Integer mode (left justified, 2 s complement) IEEE 32-bit floating point
Module conversion method	Sigma-Delta
Isolation voltage	250V (continuous), basic insulation type, input channels-to-backplane, and input channel-to-channel
Module keying	Electronic, software configurable
Removable terminal block	1756-TBNH 1756-TBSH
RTB keying	User-defined mechanical
Slot width	1
Wire category	2 <sup>(2)</sup>
Enclosure type	None (open-style)
North American temperature code	T4A
IEC temperature code	T4

(1) Notch filter dependent.

(2) Use this conductor category information for planning conductor routing as described in the system-level installation manual. See the Industrial Automation Wiring and Grounding Guidelines, publication [1770-4.1](#).

**Environmental Specifications - 1756-IF6I**

Attribute	1756-IF6I
Temperature, operating IEC 60068-2-1 (Test Ad, Operating Cold), IEC 60068-2-2 (Test Bd, Operating Dry Heat), IEC 60068-2-14 (Test Nb, Operating Thermal Shock)	0...60 °C (32...140 °F)
Temperature, surrounding air, max	60 °C (140 °F)
Temperature, nonoperating IEC 60068-2-1 (Test Ab, Unpackaged Nonoperating Cold), IEC 60068-2-2 (Test Bb, Unpackaged Nonoperating Dry Heat), IEC 60068-2-14 (Test Na, Unpackaged Nonoperating Thermal Shock)	-40...+85 °C (-40...+185 °F)
Relative humidity IEC 60068-2-30 (Test dB, Unpackaged Damp Heat)	5...95% noncondensing
Vibration IEC 60068-2-6 (Test Fc, Operating)	2 g @ 10...500 Hz
Shock, operating IEC 60068-2-27 (Test Ea, Unpackaged Shock)	30 g
Shock, nonoperating IEC 60068-2-27 (Test Ea, Unpackaged Shock)	50 g
Emissions	IEC 61000-6-4
ESD immunity IEC 61000-4-2	6 kV contact discharges 8 kV air discharges

**Environmental Specifications - 1756-IF6I (continued)**

Attribute	1756-IF6I
Radiated RF immunity IEC 61000-4-3	10V/m with 1 kHz sine-wave 80% AM from 80 . . 2000 MHz 10V/m with 200 Hz 50% Pulse 100% AM @ 900 MHz 10V/m with 200 Hz 50% Pulse 100% AM @ 1890 MHz 3V/m with 1 kHz sine-wave 80% AM from 2000 . . 2700 MHz
EFT/B immunity IEC 61000-4-4	±2 kV at 5 kHz on shielded signal ports
Surge transient immunity IEC 61000-4-5	±2 kV line-earth (CM) on shielded signal ports
Conducted RF immunity IEC 61000-4-6	10V rms with 1 kHz sine-wave 80% AM from 150 kHz . . 80 MHz on shielded signal ports

**Certifications - 1756-IF6I**

Certification (when product is marked) <sup>(1)</sup>	1756-IF6I
UL	UL Listed Industrial Control Equipment. See UL File E65584.
CSA	CSA Certified Process Control Equipment. See CSA File LR54689C. CSA Certified Process Control Equipment for Class I, Division 2 Group A,B,C,D Hazardous Locations. See CSA File LR69960C.
CE	European Union 2014/30/EU EMC Directive, compliant with: <ul style="list-style-type: none"> <li>• EN 61326-1; Meas./Control/Lab., Industrial Requirements</li> <li>• EN 61000-6-2; Industrial Immunity</li> <li>• EN 61000-6-4; Industrial Emissions</li> <li>• EN 61131-2; Programmable Controllers (Clause 8, Zone A &amp; B)</li> </ul> European Union 2014/35/EU LVD, compliant with: EN 61131-2; Programmable Controllers (Clause 11)
RCM	Australian Radiocommunications Act, compliant with: EN 61000-6-4; Industrial Emissions
Ex	European Union 2014/34/EU ATEX Directive, compliant with: <ul style="list-style-type: none"> <li>• EN 60079-15; Potentially Explosive Atmospheres, Protection "n"</li> <li>• EN 60079-0; General Requirements II 3 G Ex nA IIC T4 X Gc</li> </ul>
FM	FM Approved Equipment for use in Class I Division 2 Group A,B,C,D Hazardous Locations
KC	Korean Registration of Broadcasting and Communications Equipment, compliant with: Article 58-2 of Radio Waves Act, Clause 3
EAC	Russian Customs Union TR CU 020/2011 EMC Technical Regulation Russian Customs Union TR CU 004/2011 LV Technical Regulation

(1) See the Product Certification link at [rok.auto/certifications](http://rok.auto/certifications) for Declarations of Conformity, Certificates, and other certification details.

## 1756-IF8, 1756-IF8K

### ControlLogix voltage/current analog input module

**1756-IF8, 1756-IF8K Differential Current**

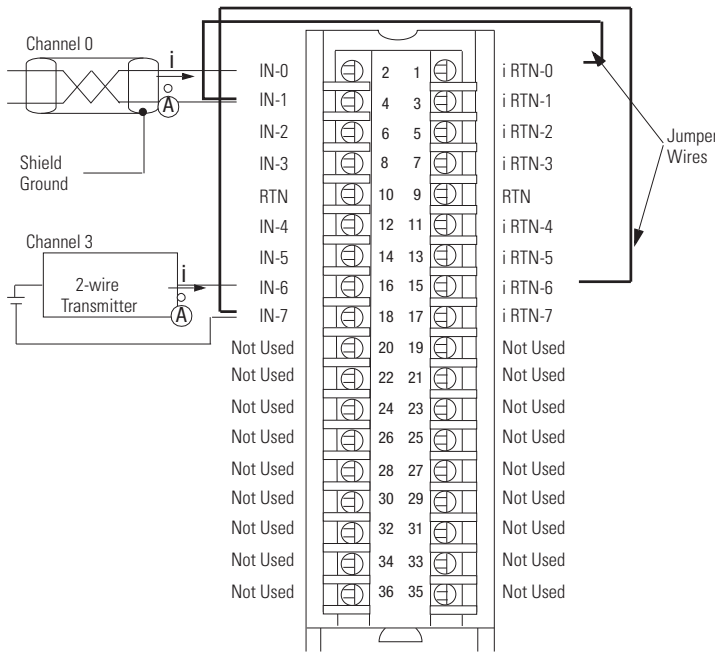

**1756-IF8, 1756-IF8K Differential Voltage**

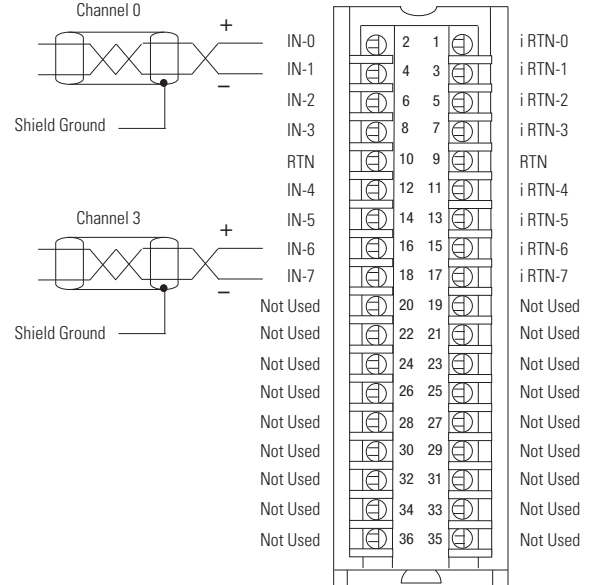

- Use this table when wiring your module in Differential mode.

This channel	Uses these terminals
Channel 0	IN-0 (+), IN-1 (-), i RTN-0
Channel 1	IN-2 (+), IN-3 (-), i RTN-2
Channel 2	IN-4 (+), IN-5 (-), i RTN-4
Channel 3	IN-6 (+), IN-7 (-), i RTN-6

- All terminals marked RTN are connected internally.
- A 249 Ω current loop resistor is located between IN-x and i RTN-x terminals.
- If multiple (+) or multiple (-) terminals are tied together, connect that tie point to an RTN terminal to maintain the module accuracy.
- Place additional loop devices (such as strip chart recorders) at the A location in the current loop.

**IMPORTANT:** When operating in 2-channel, High-Speed mode, only use channels 0 and 2.

- Use this table when wiring your module in Differential mode.

This channel	Uses these terminals
Channel 0	IN-0 (+), IN-1 (-)
Channel 1	IN-2 (+), IN-3 (-)
Channel 2	IN-4 (+), IN-5 (-)
Channel 3	IN-6 (+), IN-7 (-)

- All terminals marked RTN are connected internally.
- If multiple (+) or multiple (-) terminals are tied together, connect that tie point to an RTN terminal to maintain the module accuracy.
- Terminals marked RTN or i RTN are not used for differential voltage wiring.

**IMPORTANT:** When operating in 2-channel, High-Speed mode, only use channels 0 and 2.

**1756-IF8, 1756-IF8K Single-ended Current**

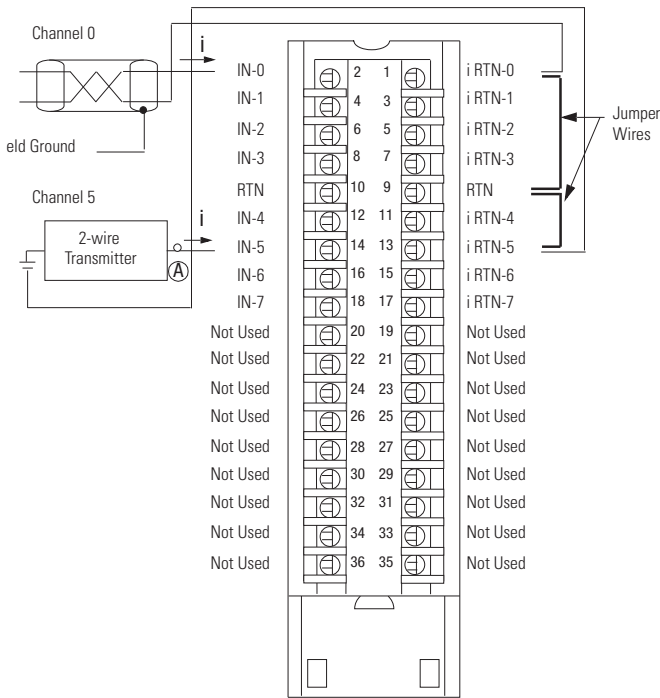

**1756-IF8, 1756-IF8K Single-ended Voltage**

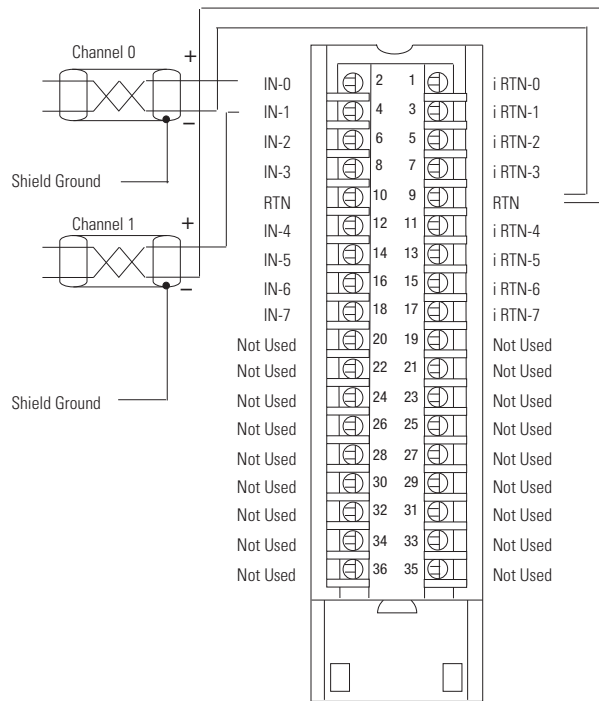

- All terminals marked RTN are connected internally.
- For current applications, all terminals marked iRTN must be wired to terminals marked RTN.
- A 249 Ω current loop resistor is located between IN-x and iRTN-x terminals.
- Place additional loop devices (such as strip chart recorders) at the A location in the current loop.

- All terminals marked RTN are connected internally.
- Terminals marked iRTN are not used for single-ended voltage wiring.

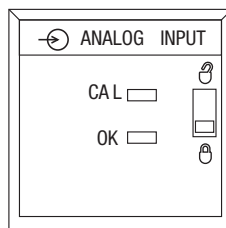

**Technical Specifications - 1756-IF8, 1756-IF8K**

Attribute	1756-IF8, 1756-IF8K
Inputs	Eight single-ended Four differential Two high-speed differential
Input range	±10V 0...10V 0...5V 0...20 mA
Resolution	±10.25V: 320 µV/count (15 bits plus sign bipolar) 0...10.25V: 160 µV/count (16 bits) 0...5.125V: 80 µV/count (16 bits) 0...20.5mA: 0.32 µA/count (16 bits)
Current draw @ 5.1V	150 mA
Current draw @ 24V	40 mA
Total backplane power	1.73 W
Voltage and current ratings	Backplane: 5.1V DC, 150 mA max, 24V DC, 40 mA max Input voltage range: -10...+10V Input current range: 4...20mA Limited to 100VA
Power consumption	1.73 W
Power dissipation	Voltage: 1.73 W Current 2.33 W
Thermal dissipation	Voltage: 5.88 BTU/hr Current: 7.92 BTU/hr
Input impedance	Voltage: >1 MΩ Current: 249 Ω
Open circuit detection time	Differential voltage: Positive full scale reading within 5 s Single-ended/diff. current: Negative full scale reading within 5 s Single-ended voltage: Even-numbered channels go to positive full scale reading within 5 s, odd-numbered channels go to negative full scale reading within 5 s
Overvoltage protection, max	Voltage: 30V DC Current: 8V DC
Normal mode noise rejection	>80 dB @ 50/60 Hz <sup>(2)</sup>
Common mode noise rejection	>100 dB @ 50/60 Hz
Calibrated accuracy 25 °C (77 °F)	Voltage: Better than 0.05% of range Current: Better than 0.15% of range
Calibration interval	12 months
Offset drift	45 µV/°C
Gain drift with temperature	Voltage: 15 ppm/°C Current: 20 ppm/°C
Module error	Voltage: 0.1% of range Current: 0.3% of range
Module input scan time, min	8 pt single-ended (floating point): 16...488 ms 4 pt differential (floating point): 8...244 ms 2 pt differential (floating point): 5...122 m <sup>(1)</sup>
Onboard data alarming	Yes
Scaling to engineering units	Yes
Real-time channel sampling	Yes

**Technical Specifications - 1756-IF8, 1756-IF8K (continued)**

Attribute	1756-IF8, 1756-IF8K
Data format	Integer mode (left justified, 2 s complement) IEEE 32-bit floating point
Module conversion method	Sigma-Delta
Isolation voltage	250V (continuous), Reinforced insulation type, Inputs to Backplane. No isolation between individual Inputs.
Module keying	Electronic, software configurable
Removable terminal block	1756-TBCH 1756-TBS6H
RTB keying	User-defined mechanical
Slot width	1
Wire size	1756-TBCH Single wire connection: 0.33...2.1 mm <sup>2</sup> (22...14 AWG) solid or stranded shielded copper wire, rated at 105 °C (221 °F) or greater, 1.2 mm (3/64 in.) insulation max  1756-TBS6H Single wire connection: 0.33...2.1 mm <sup>2</sup> (22...14 AWG) solid or stranded shielded copper wire, rated at 105 °C (221 °F) or greater, 1.2 mm (3/64 in.) insulation max
Terminal block torque specs	1756-TBCH: 0.5 N·m (4.4 lb-in)
Wiring category <sup>(1)</sup>	2 - on signal ports
Enclosure type	None (open-style)
North American temp code	T4A
ATEX temp code	T4
IECEX temp code	T4

(1) Use this Conductor Category information for planning conductor routing. See the Industrial Automation Wiring and Grounding Guidelines, publication [1770-4.1](#).

(2) Notch filter dependent.

**Environmental Specifications - 1756-IF8, 1756-IF8K**

Attribute	1756-IF8, 1756-IF8K
Temperature, operating IEC 60068-2-1 (Test Ad, Operating Cold), IEC 60068-2-2 (Test Bd, Operating Dry Heat), IEC 60068-2-14 (Test Nb, Operating Thermal Shock)	0 °C < Ta < +60 °C (+32 °F < Ta < +140 °F)
Temperature, surrounding air, max	60 °C (140 °F)
Temperature, nonoperating IEC 60068-2-1 (Test Ab, Unpackaged Nonoperating Cold), IEC 60068-2-2 (Test Bb, Unpackaged Nonoperating Dry Heat), IEC 60068-2-14 (Test N/A, Unpackaged Nonoperating Thermal Shock)	-40...+85 °C (-40...+185 °F)
Relative humidity IEC 60068-2-30 (Test dB, Unpackaged Damp Heat)	5...95% noncondensing
Vibration IEC 60068-2-6 (Test Fc, Operating)	2 g @ 10...500 Hz
Shock, operating IEC 60068-2-27 (Test Ea, Unpackaged Shock)	30 g
Shock, nonoperating IEC 60068-2-27 (Test Ea, Unpackaged Shock)	50 g
Emissions	IEC 61000-6-4
ESD immunity IEC 61000-4-2	6 kV contact discharges 8 kV air discharges

**Environmental Specifications - 1756-IF8, 1756-IF8K (continued)**

Attribute	1756-IF8, 1756-IF8K
Radiated RF immunity IEC 61000-4-3	10V/m with 1 kHz sine-wave 80% AM from 80...2000 MHz 10V/m with 200 Hz 50% Pulse 100% AM @ 900 MHz 10V/m with 200 Hz 50% Pulse 100% AM @ 1890 MHz 3V/m with 1 kHz sine-wave 80% AM from 2000...2700 MHz
EFT/B immunity IEC 61000-4-4	±2 kV at 5 kHz on signal ports
Surge transient immunity IEC 61000-4-5	±2 kV line-earth (CM) on shielded ports
Conducted RF immunity IEC 61000-4-6	10V rms with 1 kHz sine-wave 80% AM from 150 kHz...80 MHz

**Certifications - 1756-IF8, 1756-IF8K**

Certification (when product is marked) <sup>(1)</sup>	1756-IF8, 1756-IF8K
UL	UL Listed Industrial Control Equipment. See UL File E65584.
CSA	CSA Certified Process Control Equipment. See CSA File LR54689C. CSA Certified Process Control Equipment for Class I, Division 2 Group A,B,C,D Hazardous Locations. See CSA File LR69960C.
FM	FM Approved Equipment for use in Class I Division 2 Group A,B,C,D Hazardous Locations
CE	European Union 2014/30/EU EMC Directive, compliant with: <ul style="list-style-type: none"> <li>EN 61326-1; Meas./Control/Lab., Industrial Requirements</li> <li>EN 61000-6-2; Industrial Immunity</li> <li>EN 61000-6-4; Industrial Emissions</li> <li>EN 61131-2; Programmable Controllers (Clause 8, Zone A &amp; B)</li> </ul> European Union 2014/35/EU LVD, compliant with: EN 61131-2; Programmable Controllers (Clause 11)
RCM	Australian Radiocommunications Act, compliant with: EN 61000-6-4; Industrial Emissions
Ex	European Union 2014/34/EU ATEX Directive, compliant with: <ul style="list-style-type: none"> <li>EN 60079-0; General Requirements</li> <li>EN 60079-15; Potentially Explosive Atmospheres, Protection "n"</li> <li>II 3 G Ex nA IIC T4 Gc</li> <li>DEMKO15ATEX1482X</li> </ul>
IECEX	IECEX System, compliant with: <ul style="list-style-type: none"> <li>IEC 60079-0; General Requirements</li> <li>IEC 60079-15; Potentially Explosive Atmospheres, Protection "n"</li> <li>II 3 G Ex nA IIC T4 Gc</li> <li>IECEX UL 15.0053X</li> </ul>
KC	Korean Registration of Broadcasting and Communications Equipment, compliant with: Article 58-2 of Radio Waves Act, Clause 3
EAC	Russian Customs Union TR CU 020/2011 EMC Technical Regulation Russian Customs Union TR CU 004/2011 LV Technical Regulation

(1) See the Product Certification link at [rok.auto/certifications](http://rok.auto/certifications) for Declarations of Conformity, Certificates, and other certification details.



## 1756-IF8H, 1756-IF8HK

ControlLogix voltage/current analog input module with HART protocol

**1756-IF8H, 1756-IF8HK Current**

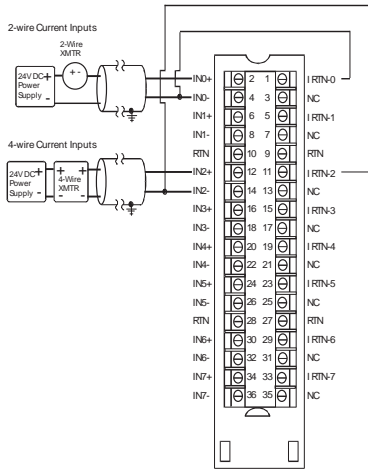

**1756-IF8H, 1756-IF8HK Voltage**

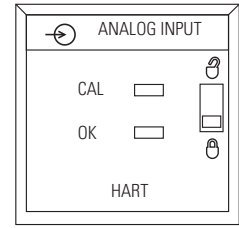
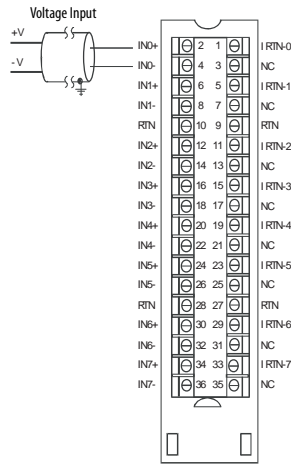

### Technical Specifications - 1756-IF8H, 1756-IF8HK

Attribute	1756-IF8H, 1756-IF8HK
Inputs	Eight differential voltage or current inputs, one HART modem per module
Input range	±10V 0...5V 1...5V 0...10V 0...20 mA 4...20 mA
Resolution	16...21 bits
Voltage and current ratings	Backplane: 5.1V DC, 300 mA, 24V DC, 135 mA Input voltage range: -10...+10V Input current range: 0...20 mA, 4...20mA
Total backplane power	4.77 W
Power dissipation	Voltage: 3.21 W Current: 4.01 W
Thermal dissipation	Voltage: 11.0 BTU/hr Current: 13.7 BTU/hr
Input impedance	—
Open circuit detection time	Positive full scale reading within 5 s
Overvoltage protection, max	Voltage: 30V DC Current: 8V DC
Normal mode noise rejection	> 80 dB @ 50/60 Hz
Common mode noise rejection	> 100 dB @ 50/60 Hz
Calibrated accuracy	Voltage: Better than 0.05% of range Current: Better than 0.15% of range
Calibration interval	12 months
Offset drift	90 µV/°C
Gain drift with temperature	Voltage: 10 ppm/°C Current: 20 ppm/°C

**Technical Specifications - 1756-IF8H, 1756-IF8HK**

Attribute	1756-IF8H, 1756-IF8HK
Module error	Voltage: 0.1% of range Current: 0.3% of range
Module HART scan time	Analog: 18...488 ms (filter dependent). HART: typically 1 s per HART channel enabled. Estimate 10 s if all 8 channels have HART enabled. Typically 1 s per HART channel enabled. Estimate 10 s if all 8 channels have HART enabled. Pass through messages, handheld communicators, secondary masters, communication errors, or configuration changes can significantly increase the update time
Data format	Integer mode (left justified, 2 s complement) IEEE 32-bit floating point
Input conversion method	Successive approximation
Output conversion method	R-Ladder DAC, monotonicity with no missing codes
Isolation voltage	50V (continuous), Basic insulation type, input channels to backplane No isolation between individual input channels
Module keying	Electronic, software configurable
Removable terminal block	1756-TBCH 1756-TBS6H
RTB keying	User-defined mechanical
Slot width	1
Wire size	1756-TBCH Single wire connection: 0.33...2.1 mm <sup>2</sup> (22...14 AWG) solid or stranded shielded copper wire, rated at 105 °C (221 °F, or greater, 1.2 mm (3/64 in.) insulation max  1756-TBS6H Single wire connection: 0.33...2.1 mm <sup>2</sup> (22...14 AWG) solid or stranded shielded copper wire, rated at 105 °C (221 °F) or greater, 1.2 mm (3/64 in.) insulation max
Terminal block torque specs	1756-TBCH 0.5 N·m (4.4 lb·in)
Wire category <sup>(1)</sup>	2 - on signal ports
Wire type	Copper
Enclosure type rating	None (open-style)
North American temp code	T5
ATEX temp code	T4
IECEx temp code	T4

(1) Use this conductor category information for planning conductor routing as described in the system-level installation manual. See the Industrial Automation Wiring and Grounding Guidelines, publication [1770-4.1](#).

**Environmental Specifications - 1756-IF8H, 1756-IF8HK**

Attribute	1756-IF8H, 1756-IF8HK
Temperature, operating IEC 60068-2-1 (Test Ad, Operating Cold), IEC 60068-2-2 (Test Bd, Operating Dry Heat), IEC 60068-2-14 (Test Nb, Operating Thermal Shock)	0 °C < Ta < +60 °C (+32 °F < Ta < +140 °F)
Temperature, surrounding air, max	60 °C (140 °F)
Temperature, nonoperating IEC 60068-2-1 (Test Ab, Unpackaged Nonoperating Cold), IEC 60068-2-2 (Test Bb, Unpackaged Nonoperating Dry Heat), IEC 60068-2-14 (Test N/A, Unpackaged Nonoperating Thermal Shock)	-40...+85 °C (-40...+185 °F)
Relative humidity IEC 60068-2-30 (Test dB, Unpackaged Damp Heat)	5...95% noncondensing

**Environmental Specifications - 1756-IF8H, 1756-IF8HK**

Attribute	1756-IF8H, 1756-IF8HK
Vibration IEC 60068-2-6 (Test Fc, Operating)	2 g @ 10...500 Hz
Shock, operating IEC 60068-2-27 (Test Ea, Unpackaged Shock)	30 g
Shock, nonoperating IEC 60068-2-27 (Test Ea, Unpackaged Shock)	50 g
Emissions	IEC 61000-6-4
ESD immunity IEC 61000-4-2	6 kV contact discharges 8 kV air discharges
Radiated RF immunity IEC 61000-4-3	10V/m with 1 kHz sine-wave 80% AM from 80...2000 MHz 10V/m with 200 Hz 50% Pulse 100% AM @ 900 MHz 10V/m with 200 Hz 50% Pulse 100% AM @ 1890 MHz 1V/m with 1 kHz sine-wave 80% AM from 2000...2700 MHz
EFT/B immunity IEC 61000-4-4	±2 kV at 5 kHz on signal ports
Surge transient immunity IEC 61000-4-5	±2 kV line-earth (CM) on shielded ports
Conducted RF immunity IEC 61000-4-6	10V rms with 1 kHz sine-wave 80% AM from 150 kHz...80 MHz

**Certifications - 1756-IF8H, 1756-IF8HK**

Certification (when product is marked) <sup>(1)</sup>	1756-IF8H, 1756-IF8HK
c-UL-us	UL Listed Industrial Control Equipment, certified for US and Canada. See UL File E65584. UL Listed for Class I, Division 2 Group A,B,C,D Hazardous Locations, certified for U.S. and Canada. See UL File E194810.
CE	European Union 2014/30/EU EMC Directive, compliant with: <ul style="list-style-type: none"> <li>EN 61326-1; Meas./Control/Lab., Industrial Requirements</li> <li>EN 61000-6-2; Industrial Immunity</li> <li>EN 61000-6-4; Industrial Emissions</li> <li>EN 61131-2; Programmable Controllers (Clause 8, Zone A &amp; B)</li> </ul>
RCM	Australian Radiocommunications Act, compliant with: EN 61000-6-4: Industrial Emissions
Ex	European Union 2014/34/EU ATEX Directive, compliant with: <ul style="list-style-type: none"> <li>EN 60079-0; General Requirements</li> <li>EN 60079-15; Potentially Explosive Atmospheres, Protection "n"</li> <li>II 3 G Ex nA IIC T4 Gc</li> <li>DEMKO12ATEX1219040X</li> </ul>
IECEx	IECEx System, compliant with: <ul style="list-style-type: none"> <li>IEC 60079-0; General Requirements</li> <li>IEC 60079-15; Potentially Explosive Atmospheres, Protection "n"</li> <li>II 3 G Ex nA IIC T4 Gc</li> <li>IECEx UL 16.0109X</li> </ul>
KC	Korean Registration of Broadcasting and Communications Equipment, compliant with: Article 58-2 of Radio Waves Act, Clause 3
EAC	Russian Customs Union TR CU 020/2011 EMC Technical Regulation Russian Customs Union TR CU 004/2011 LV Technical Regulation

(1) See the Product Certification link at [rok.auto/certifications](http://rok.auto/certifications) for Declarations of Conformity, Certificates, and other certification details.

## 1756-IF8I, 1756-IF8IK

ControlLogix isolated voltage/current analog input module.

1756-IF8I, 1756-IF8IK Module Wiring Diagram -Current Mode with External Loop Power

**IMPORTANT:** Remember the following:

- In this wiring diagram, an external, user-provided power supply provides 24V DC loop power.
- If separate power sources are used, do not exceed the specific isolation voltage as listed in the specifications.
- Place additional loop devices, for example, strip chart recorders, at either 'A' location in the current loop.

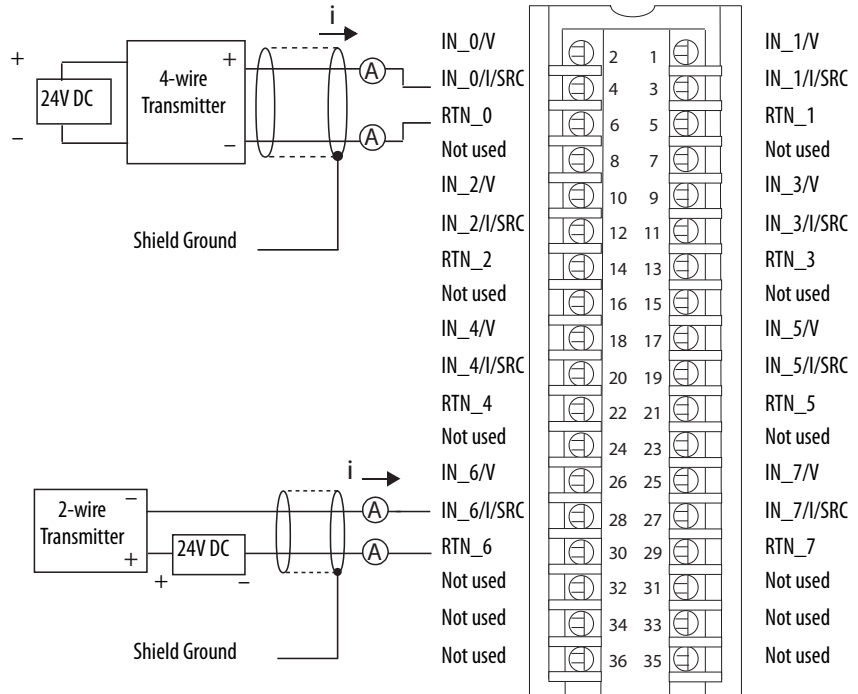

1756-IF8I, 1756-IF8IK Module Wiring Diagram -Current Mode with Internal Loop Power

**IMPORTANT:** Remember the following:

- In this wiring diagram, the module provides 24V DC loop power.
- If separate power sources are used, do not exceed the specific isolation voltage as listed in the specifications.
- Place additional loop devices, for example, strip chart recorders, at either 'A' location in the current loop.

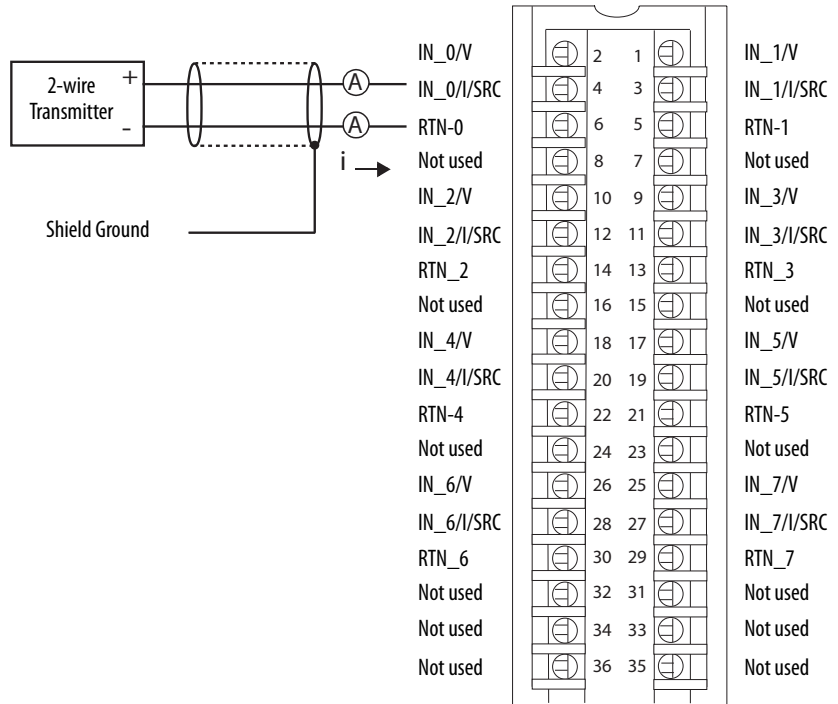

**1756-IF8I, 1756-IF8IK Module Wiring Diagram - Voltage Mode**

**IMPORTANT:** If separate power sources are used, do not exceed the specific isolation voltage as listed in the specifications.

Device  
External  
Power

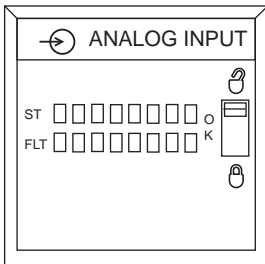
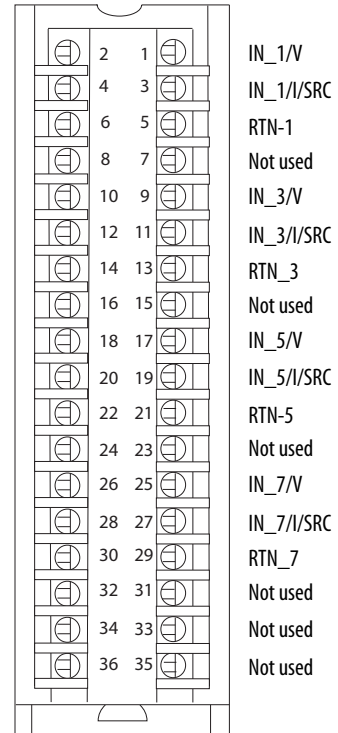
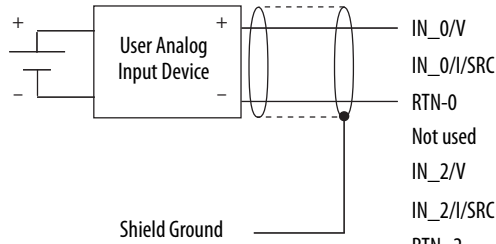

**Technical Specifications - 1756-IF8I, 1756-IF8IK**

Attribute	1756-IF8I, 1756-IF8IK
Inputs	Eight isolated channels - Any combination of Voltage or Current mode
Voltage and current ratings	Backplane: 5.1V DC 200 mA, 24V DC 400 mA Input Voltage: -10V to +10V, 0V to 10V, 0V to 5V Input Current: 0 mA to 20 mA Output Current: 0 mA to 20 mA
Input ranges	-10...10V 0...10V 0...5V 0...20 mA
Resolution	24-bit ±10.5V (1.49 µV/count) 0...10.5V (1.49 µV/count) 0...5.25V (1.49 µV/count) 0...21 mA (2.99 nA/count)
Current draw @ 5.1V	200 mA
Current draw @ 24V	Voltage/Non-sourcing Current mode: 150 mA Sourcing Current mode: 400 mA (In Sourcing Current mode, the channel provides loop power.)
Total backplane power	Voltage/Non-sourcing Current mode: 4.6 W Sourcing Current mode: 10.6 W
Power dissipation	Voltage mode: 4.6 W (15.7 BTU/hr) Non-sourcing Current mode: 5.1 W (17.4 BTU/hr) Sourcing Current mode: 7.3 W (24.9 BTU/hr)

**Technical Specifications - 1756-IF8I, 1756-IF8IK**

Attribute	1756-IF8I, 1756-IF8IK
Thermal dissipation	Voltage mode: 15.7 BTU/hr Non-sourcing Current mode: 17.4 BTU/hr Sourcing Current mode: 24.9 BTU/hr
Input impedance, approx	Voltage mode: 1 G $\Omega$ (powered); 7500 $\Omega$ (unpowered) Current mode: 125 $\Omega$
Sourcing voltage, min	20V DC
Sourcing voltage, max	36V DC (open circuit)
Sourcing current, max	Current Limited < 45 mA (IN_x/I/SRC to RTN_x)
Open circuit detection time	5 s
Overvoltage protection, max	$\pm$ 30V DC
Normal mode noise rejection	80 dB @ 60 Hz <sup>(1)</sup>
Common mode noise rejection	120 dB @ 50/60 Hz
Channel bandwidth	Notch filter configuration dependent See publication <a href="#">1756-UM540</a> for possible values.
Settling time	Notch filter configuration dependent See publication <a href="#">1756-UM540</a> for possible values.
Calibrated accuracy 25 °C (77 °F)	0.05%
Module error over full temperature range	0.1%
Module input scan time, min	1 ms
Onboard data alarming	Yes
Scaling to engineering units	Yes
Real-time channel sampling	Yes - Rate set by Requested Packet Interval rate
Data format	IEEE 32-bit floating point
Module conversion method	Sigma-Delta
Isolation voltage	250V (continuous), reinforced insulation type, inputs to backplane 250V (continuous), basic insulation type, input to input
Module keying	Electronic, software configurable
Removable terminal block	1756-TBCH 1756-TBS6H
RTB keying	User-defined mechanical
Slot width	1
Wire size	0.33... 2.1 mm <sup>2</sup> (22...14 AWG) solid or stranded shielded copper wire rated at 90 °C (194 °F), or greater, 1.2 mm (3/64 in.) insulation max
Wire category	2 on signal ports <sup>(2)</sup>
Enclosure type	None (open-style)
North American temperature code	T4
IEC temperature code	T4

(1) Notch filter dependent.

(2) Use this conductor category information for planning conductor routing as described in the system-level installation manual. See the Industrial Automation Wiring and Grounding Guidelines, publication [1770-4.1](#).

**Environmental Specifications - 1756-IF8I, 1756-IF8IK**

<b>Attribute</b>	<b>1756-IF8I, 1756-IF8IK</b>
Temperature, operating IEC 60068-2-1 (Test Ad, Operating Cold), IEC 60068-2-2 (Test Bd, Operating Dry Heat), IEC 60068-2-14 (Test Nb, Operating Thermal Shock)	0...60 °C (32...140 °F)
Temperature, surrounding air, max	60 °C (140 °F)
Temperature, nonoperating IEC 60068-2-1 (Test Ab, Unpackaged Nonoperating Cold), IEC 60068-2-2 (Test Bb, Unpackaged Nonoperating Dry Heat), IEC 60068-2-14 (Test N/A, Unpackaged Nonoperating Thermal Shock)	-40...+85 °C (-40...+185 °F)
Relative humidity IEC 60068-2-30 (Test dB, Unpackaged Damp Heat)	5...95% noncondensing
Vibration IEC 60068-2-6 (Test Fc, Operating)	2 g @ 10...500 Hz
Shock, operating IEC 60068-2-27 (Test Ea, Unpackaged Shock)	30 g
Shock, nonoperating IEC 60068-2-27 (Test Ea, Unpackaged Shock)	50 g
Emissions	IEC 61000-6-4
ESD immunity IEC 61000-4-2	6 kV contact discharges 8 kV air discharges
Radiated RF immunity IEC 61000-4-3	10V/m with 1 kHz sine-wave 80% AM from 80...2000 MHz 10V/m with 200 Hz 50% Pulse 100% AM @ 900 MHz 10V/m with 200 Hz 50% Pulse 100% AM @ 1890 MHz 3V/m with 1 kHz sine-wave 80% AM from 2000...2700 MHz
EFT/B immunity IEC 61000-4-4	±4 kV at 5 kHz on shielded signal ports
Surge transient immunity IEC 61000-4-5	±2 kV line-earth (CM) on shielded signal ports
Conducted RF immunity IEC 61000-4-6	10V rms with 1 kHz sine-wave 80% AM from 150 kHz...80 MHz

**Certifications - 1756-IF8I, 1756-IF8IK**

<b>Certification (when product is marked)<sup>(1)</sup></b>	<b>1756-IF8I, 1756-IF8IK</b>
c-UL-us	UL Listed Industrial Control Equipment, certified for US and Canada. See UL File E65584. UL Listed for Class I, Division 2 Group A,B,C,D Hazardous Locations, certified for U.S. and Canada. See UL File E194810.
CE	European Union 2014/30/EU EMC Directive, compliant with: <ul style="list-style-type: none"> <li>• EN 61326-1; Meas./Control/Lab., Industrial Requirements</li> <li>• EN 61000-6-2; Industrial Immunity</li> <li>• EN 61000-6-4; Industrial Emissions</li> <li>• EN 61131-2; Programmable Controllers (Clause 8, Zone A &amp; B)</li> </ul> European Union 2014/35/EU LVD, compliant with: <ul style="list-style-type: none"> <li>• EN 61131-2; Programmable Controllers (Clause 11)</li> </ul>
RCM	Australian Radiocommunications Act, compliant with: <ul style="list-style-type: none"> <li>• EN 61000-6-4; Industrial Emissions</li> </ul>
Ex	European Union 2014/34/EU ATEX Directive, compliant with: <ul style="list-style-type: none"> <li>• EN 60079-15; Potentially Explosive Atmospheres, Protection "n"</li> <li>• EN 60079-0; General Requirements</li> <li>• II 3 G Ex nA IIC T4 Gc</li> <li>• DEMKO13ATEX1325026X</li> </ul>
IECEX	IECEX System, compliant with: <ul style="list-style-type: none"> <li>• IEC 60079-0; General Requirements</li> <li>• IEC 60079-15; Potentially Explosive Atmospheres, Protection "n"</li> <li>• II 3 G Ex nA IIC T4 Gc</li> <li>• IECEX UL 14.0008X</li> </ul>
KC	Korean Registration of Broadcasting and Communications Equipment, compliant with: Article 58-2 of Radio Waves Act, Clause 3
EAC	Russian Customs Union TR CU 020/2011 EMC Technical Regulation Russian Customs Union TR CU 004/2011 LV Technical Regulation

(1) See the Product Certification link at [rok.auto/certifications](http://rok.auto/certifications) for Declarations of Conformity, Certificates, and other certification details.



## 1756-IF8IH, 1756-IF8IHK

ControlLogix isolated current analog input module with HART protocol

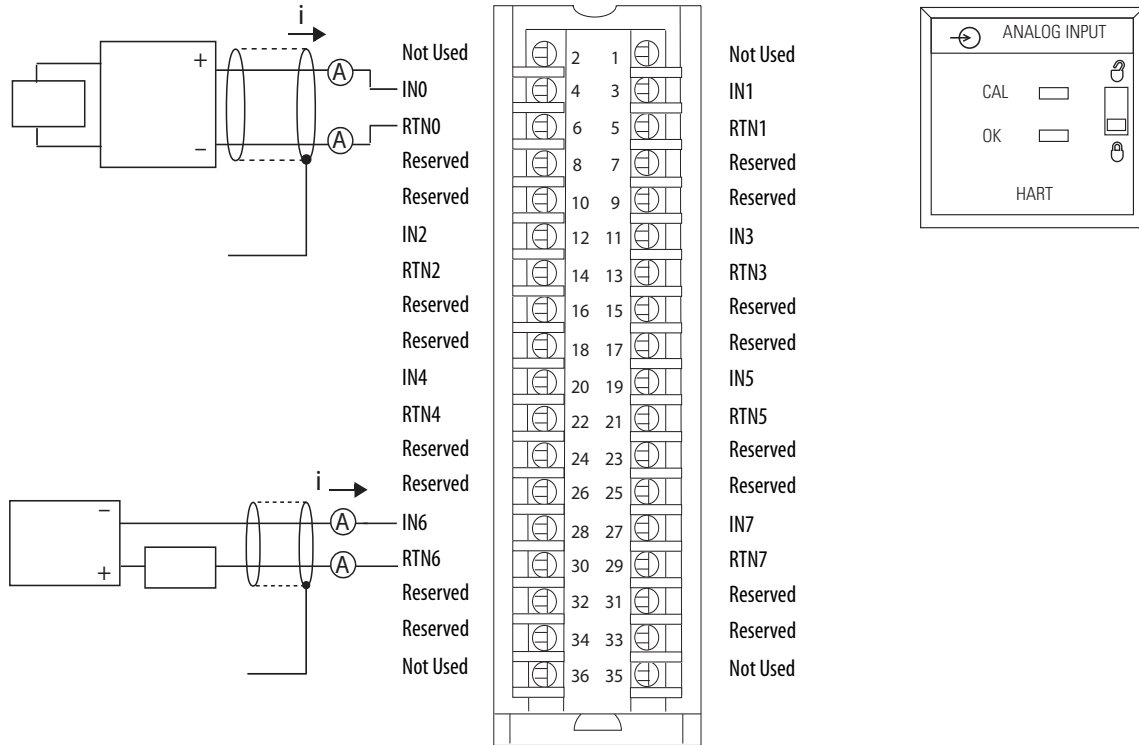

### Technical Specifications - 1756-IF8IH, 1756-IF8IHK

Attribute	1756-IF8IH, 1756-IF8IHK
Inputs	Eight current inputs
Input range	0...20 mA (0...20.58 mA) 4...20 mA (3.42...20.58 mA)
Resolution	16...21 bits
Voltage and current ratings	Backplane: 210 mA @ 5.1V DC, 110 mA @ 24V DC Input voltage range: 5...30V DC Input current range: 0...20 mA, 4...20 mA
Power dissipation within module	4 W
Inrush current	400 mA @ 5V 450 mA @ 24V
Isolation voltage	250V (continuous) Reinforced Insulation Type, inputs to backplane. Basic Insulation Type, input to input, and inputs to ground.
Input impedance	250 Ω ±5 Ω
Open circuit detection time	5 s (4...20 mA range only)
Input overvoltage protection	+28.8V DC
Normal mode noise rejection	> 90 dB @ 50 Hz and 60 Hz with 10 Hz filter > 74 dB @ 50 Hz and 60 Hz with 15 Hz filter > 33 dB @ 50 Hz and > 90 dB @ 60 Hz with 20 Hz filter
Common mode noise rejection	> 90 dB @ 50 Hz and 60 Hz (10 Hz, 15 Hz, or 20 Hz filters only)
Calibrated accuracy at 25 °C with HART disabled	0.15...1.5% of full scale, filter dependent

**Technical Specifications - 1756-IF8IH, 1756-IF8IHK**

Attribute	1756-IF8IH, 1756-IF8IHK
Calibrated accuracy at 25 °C with HART enabled	1.5% of full scale with 250 Hz filter 0.5% of full scale with 100 Hz filter 0.2% of full scale with 50 Hz or 60 Hz filter 0.15% of full scale with 15 Hz or 20 Hz filter Monotonicity not guaranteed
Calibrated accuracy over full temperature range with HART enabled	1.8% of full scale with 250 Hz filter 0.8% of full scale with 100 Hz filter 0.5% of full scale with 50 Hz or 60 Hz filter 0.4% of full scale with 15 Hz or 20 Hz filter Monotonicity not guaranteed
Calibration interval	12 months typical
Input offset drift with temperature	$\leq 300 \mu\text{A}/^\circ\text{C}$
Gain drift with temperature	20 ppm/ $^\circ\text{C}$
Module error over full temperature range with HART disabled	0.3% of range (all filters)
Module scan time for all channels - analog, min	18...488 ms (filter dependent)
Typical module HART dynamic variables update time for all channels	1 s typical if all channels are HART enabled Pass through messages, handheld communications, secondary masters, communication errors, or configuration changes can significantly increase the update time.
Data format	32-bit floating point
Input conversion method	Sigma-Delta ADC (24-bit converter)
Module keying	Electronic, software configurable
Removable terminal block	1756-TBCH 1756-TBS6H
RTB keying	User-defined mechanical
Slot width	1
Wire Size	1756-TBCH Single wire connection: 0.33...2.1 mm <sup>2</sup> (22...14 AWG) solid or stranded shielded copper wire, rated at 105 °C (221 °F) or greater, 1.2 mm (3/64 in.) insulation max  1756-TBS6H Single wire connection: 0.33...2.1 mm <sup>2</sup> (22...14 AWG) solid or stranded shielded copper wire, rated at 105 °C (221 °F) or greater, 1.2 mm (3/64 in.) insulation max
Terminal block torque specs	1756-TBCH 0.4 N·m (4.4 lb·in)
Wire category	2 - on signal ports <sup>(1)</sup>
Wire type	Copper
Enclosure type	None (open-style)
North American temp code	T5
ATEX temp code	T4
IECEx temp code	T4

(1) Use this conductor category information for planning conductor routing. See Industrial Automation Wiring and Grounding Guidelines, publication [1770-4.1](#).

**Environmental Specifications - 1756-IF8IH, 1756-IF8IHK**

<b>Attribute</b>	<b>1756-IF8IH, 1756-IF8IHK</b>
Temperature, operating IEC 60068-2-1 (Test Ad, Operating Cold), IEC 60068-2-2 (Test Bd, Operating Dry Heat), IEC 60068-2-14 (Test Nb, Operating Thermal Shock)	0 °C < Ta < +60 °C (+32 °F < Ta < +140 °F)
Temperature, surrounding air, max	60 °C (140 °F)
Temperature, nonoperating IEC 60068-2-1 (Test Ab, Unpackaged Nonoperating Cold), IEC 60068-2-2 (Test Bb, Unpackaged Nonoperating Dry Heat), IEC 60068-2-14 (Test Na, Unpackaged Nonoperating Thermal Shock)	-40...+85 °C (-40...+185 °F)
Relative humidity IEC 60068-2-30 (Test dB, Unpackaged Damp Heat)	5...95% noncondensing
Vibration IEC 60068-2-6 (Test Fc, Operating)	2 g @ 10...500 Hz
Shock, operating IEC 60068-2-27 (Test Ea, Unpackaged Shock)	30 g
Shock, nonoperating IEC 60068-2-27 (Test Ea, Unpackaged Shock)	50 g
Emissions	IEC 61000-6-4
ESD immunity IEC 61000-4-2	6 kV contact discharges 8 kV air discharges
Radiated RF immunity IEC 61000-4-3	10V/m with 1 kHz sine-wave 80% AM from 80...2000 MHz 10V/m with 200 Hz 50% Pulse 100% AM @ 900 MHz 10V/m with 200 Hz 50% Pulse 100% AM @ 1890 MHz 10V/m with 1 kHz sine-wave 80% AM from 2000...2700 MHz
EFT/B immunity IEC 61000-4-4	±2 kV at 5 kHz on signal ports
Surge transient immunity IEC 61000-4-5	±2 kV line-earth (CM) on shielded ports
Conducted RF immunity IEC 61000-4-6	10V rms with 1 kHz sine-wave 80% AM from 150 kHz...80 MHz

**Certifications - 1756-IF8IH, 1756-IF8IHK**

Certification (when product is marked) <sup>(1)</sup>	1756-IF8IH, 1756-IF8IHK
c-UL-us	UL Listed Industrial Control Equipment, certified for US and Canada. See UL File E65584 UL Listed for Class I, Division 2 Group A, B, C, D Hazardous Locations, certified for US and Canada. See UL File E194810.
CE	European Union 2014/30/EU EMC Directive, compliant with: <ul style="list-style-type: none"> <li>• EN 61326-1: Meas./Control/Lab., Industrial Requirements</li> <li>• EN 61000-6-2: Industrial Immunity</li> <li>• EN 61000-6-4: Industrial Emissions</li> <li>• EN 61131-2: Programmable Controllers (Clause 8, Zone A and B)</li> </ul> European Union 2014/35/EU LVD, compliant with: <ul style="list-style-type: none"> <li>• EN 61131-2: Programmable Controllers (Clause 11)</li> </ul>
RCM	Australian Radiocommunications Act, compliant with: <ul style="list-style-type: none"> <li>• EN 61000-6-4: Industrial Emissions</li> </ul>
Ex	European Union 2014/34/EU ATEX Directive, compliant with: <ul style="list-style-type: none"> <li>• EN 60079-0; General Requirements</li> <li>• EN 60079-15; Potentially Explosive Atmospheres, Protection "n"</li> <li>• II 3 G Ex nA IIC T4 Gc</li> <li>• DEMKO14ATEX1238X</li> </ul>
IECEx	IECEx System, compliant with: <ul style="list-style-type: none"> <li>• IEC 60079-0; General Requirements</li> <li>• IEC 60079-15; Potentially Explosive Atmospheres, Protection "n"</li> <li>• II 3 G Ex nA IIC T4 Gc</li> <li>• IECEx UL 16.0110X</li> </ul>
KC	Korean Registration of Broadcasting and Communications Equipment, compliant with: Article 58-2 of Radio Waves Act, Clause 3
EAC	Russian Customs Union TR CU 020/2011 EMC Technical Regulation Russian Customs Union TR CU 004/2011 LV Technical Regulation

(1) See the Product Certification link at [rok.auto/certifications](http://rok.auto/certifications) for Declarations of Conformity, Certificates, and other certification details.

## 1756-IF16, 1756-IF16K

ControlLogix voltage/current analog input module

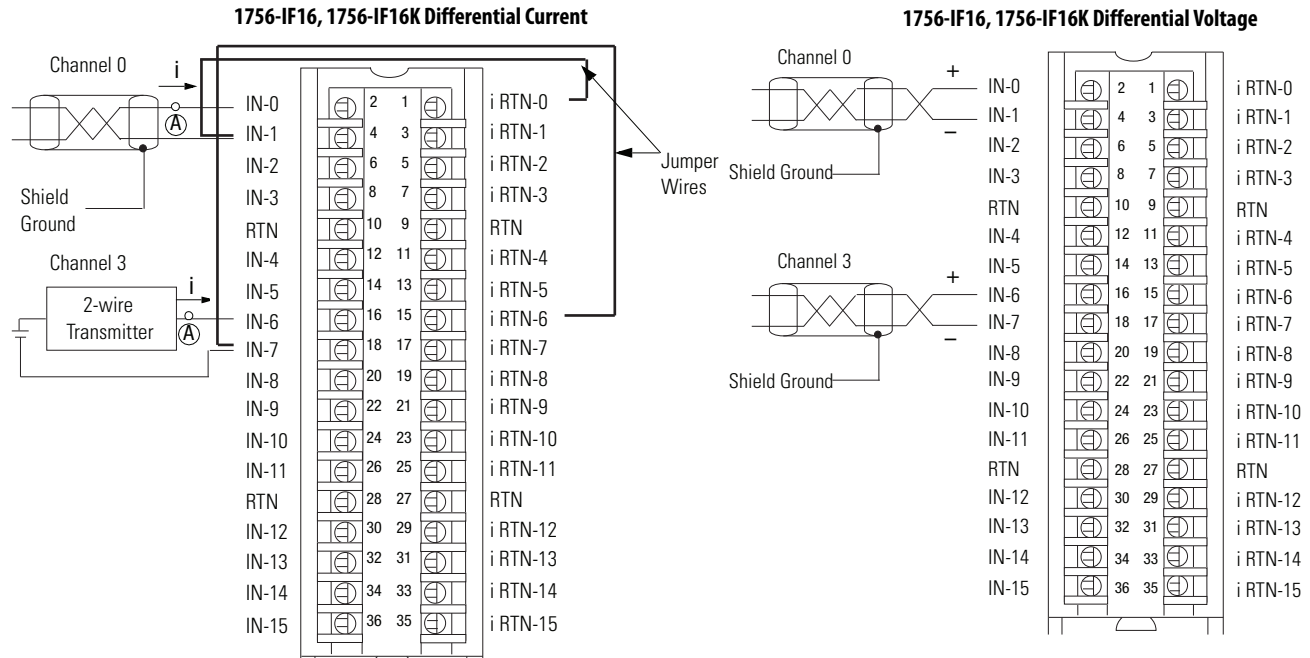

Use this table when wiring your module in Differential mode.

This channel	Uses these terminals
Channel 0	IN-0 (+), IN-1 (-), i RTN-0
Channel 1	IN-2 (+), IN-3 (-), i RTN-2
Channel 2	IN-4 (+), IN-5 (-), i RTN-4
Channel 3	IN-6 (+), IN-7 (-), i RTN-6
Channel 4	IN-8 (+), IN-9 (-), i RTN-8
Channel 5	IN-10 (+), IN-11 (-), i RTN-10
Channel 6	IN-12 (+), IN-13 (-), i RTN-12
Channel 7	IN-14 (+), IN-15 (-), i RTN-14

- All terminals marked RTN are connected internally.
- A 249 Ω current loop resistor is located between IN-x and i RTN-x terminals.
- If multiple (+) or multiple (-) terminals are tied together, connect that tie point to an RTN terminal to maintain the accuracy of the module.
- Place additional loop devices (such as strip chart recorders) at the A location in the current loop.

**IMPORTANT:** When operating in 4-channel, High-Speed mode, only use channels 0, 2, 4, and 6.

Use this table when wiring your module in Differential mode.

This channel	Uses these terminals
Channel 0	IN-0 (+), IN-1 (-)
Channel 1	IN-2 (+), IN-3 (-)
Channel 2	IN-4 (+), IN-5 (-)
Channel 3	IN-6 (+), IN-7 (-)
Channel 4	IN-8 (+), IN-9 (-)
Channel 5	IN-10 (+), IN-11 (-)
Channel 6	IN-12 (+), IN-13 (-)
Channel 7	IN-14 (+), IN-15 (-)

- All terminals marked RTN are connected internally.
- If multiple (+) or multiple (-) terminals are tied together, connect that tie point to an RTN terminal to maintain the accuracy of the module.
- Terminals marked RTN or i RTN are not used for differential voltage wiring.

**IMPORTANT:** When operating in 4-channel, High-Speed mode, only use channels 0, 2, 4, and 6.

**1756-IF16, 1756-IF16K Single-ended Current**

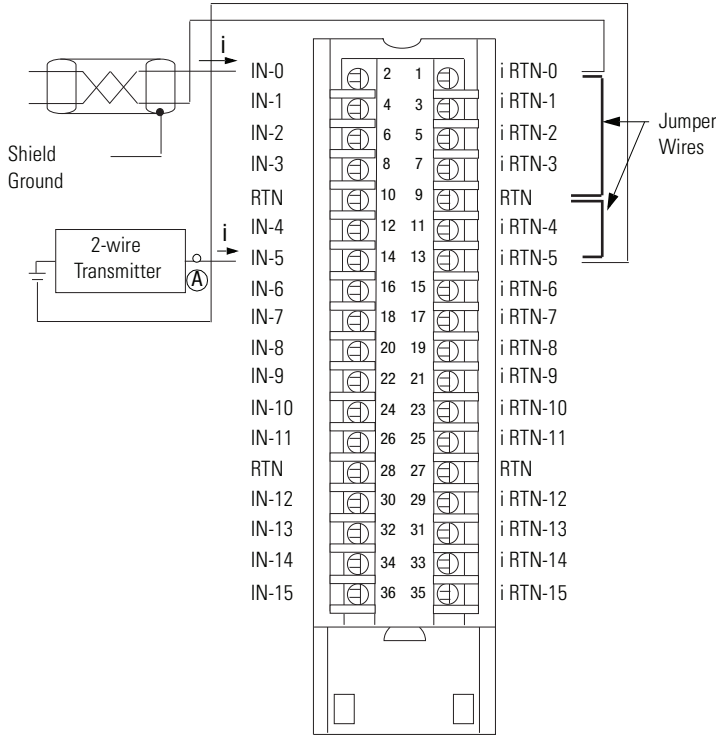

**1756-IF16, 1756-IF16K Single-ended Voltage**

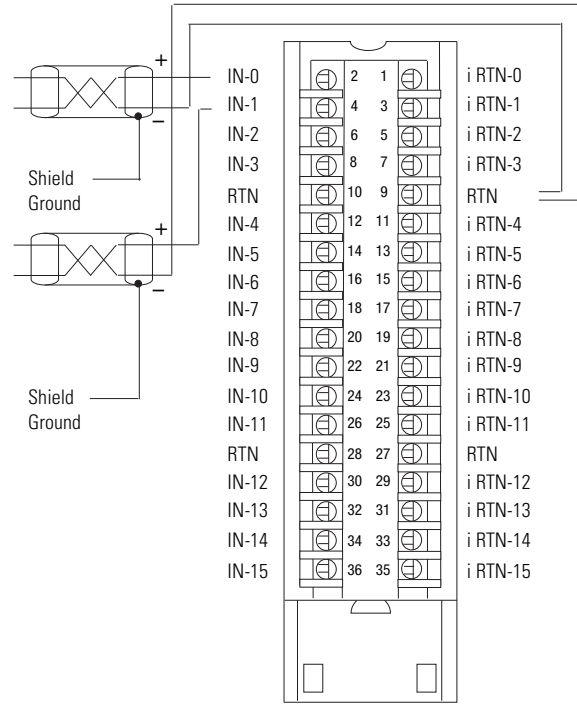

- All terminals marked RTN are connected internally.
- For current applications, all terminals marked i RTN must be wired to terminals marked RTN.
- A 249  $\Omega$  current loop resistor is located between IN-x and iRTN-x terminals.
- Place additional loop devices (such as strip chart recorders) at the A location in the current loop.

- All terminals marked RTN are connected internally.
- Terminals marked i RTN are not used for single-ended voltage wiring.

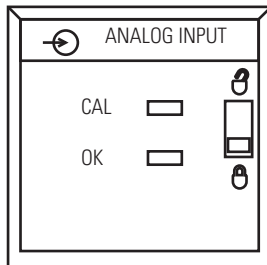

**Technical Specifications - 1756-IF16, 1756-IF16K**

Attribute	1756-IF16, 1756-IF16K
Inputs	16 single ended, 8 differential or 4 differential (high speed)
Input range	±10V 0...10V 0...5V 0...20 mA
Resolution	320 µV/count (15 bits + sign bipolar) @ ±10.25V 160 µV/count (16 bits) @ 0...10.25V 80 µV/count (16 bits) @ 0...5.125V 0.32 µA/count (16 bits) @ 0...20.5 mA
Current draw @ 5.1V	150 mA
Current draw @ 24V	65 mA
Total backplane power	2.33 W
Voltage and current ratings	Backplane: 5.1V DC, 150 mA max 24V DC, 65 mA max Input Voltage Range: -10...+10V Input Current Range: 4...20mA Limited to 100VA
Power consumption	2.3 W
Power dissipation	Voltage: 2.3 W Current: 3.9 W
Thermal dissipation	Voltage: 7.84 BTU/hr Current: 13.3 BTU/hr
Input impedance	Voltage: >10 MΩ Current: 249 Ω
Open circuit detection time	Differential voltage - Positive full scale reading within 5 s Single-ended/differential current - Negative full scale reading within 5 s Single-ended voltage - Even-numbered channels go to positive full scale reading within 5 s, odd-numbered channels go to negative full scale reading within 5 s
Overvoltage protection, max	Voltage: 30V DC Current: 8V DC
Normal mode noise rejection	>80 dB @ 50/60 Hz <sup>(2)</sup>
Common mode noise rejection	>100 dB @ 50/60 Hz
Channel bandwidth	15 Hz (-3 dB) <sup>(2)</sup>
Settling time	<80 ms to 5% of full scale <sup>(2)</sup>
Calibrated accuracy 25 °C (77 °F)	Voltage: Better than 0.05% of range Current: Better than 0.15% of range
Offset drift	45 µV/°C
Gain drift with temperature	Voltage: 15 ppm/°C Current: 20 ppm/°C
Module error	Voltage: 0.1% of range Current: 0.3% of range
Module input scan time, min	16 pt single-ended: 16...488 ms 8 pt differential: 8...244 ms 4 pt differential: 5...122 ms <sup>(2)</sup>
Onboard data alarming	Yes
Scaling to engineering units	Yes
Real-time channel sampling	Yes

**Technical Specifications - 1756-IF16, 1756-IF16K**

Attribute	1756-IF16, 1756-IF16K
Data format	Integer mode (left justified, 2 s complement) IEEE 32-bit floating point
Module conversion method	Sigma-Delta
Isolation voltage	250V (continuous), Reinforced insulation type, Inputs-to-Backplane. No isolation between individual Inputs.
Module keying	Electronic, software configurable
Removable terminal block	1756-TBCH 1756-TBS6H
RTB keying	User-defined mechanical
Slot width	1
Wire size	1756-TBCH Single wire connection: 0.33...2.1 mm <sup>2</sup> (22...14 AWG) solid or stranded shielded copper wire, rated at 105 °C (221 °F) or greater, 1.2 mm (3/64 in.) insulation max  1756-TBS6H Single wire connection: 0.33...2.1 mm <sup>2</sup> (22...14 AWG) solid or stranded shielded copper wire, rated at 105 °C (221 °F) or greater, 1.2 mm (3/64 in.) insulation max
Terminal block torque specs	1756-TBCH: 0.5 N·m (4.4 lb·in)
Wire category <sup>(1)</sup>	2 - on signal ports
Enclosure type	None (open-style)
North American temp code	T4A
ATEX temp code	T4
IECEX temp code	T4

(1) Use this Conductor Category information for planning conductor routing. See the Industrial Automation Wiring and Grounding Guidelines, publication [1770-4.1](#).

(2) Notch filter dependent.

**Environmental Specifications - 1756-IF16, 1756-IF16K**

Attribute	1756-IF16, 1756-IF16K
Temperature, operating IEC 60068-2-1 (Test Ad, Operating Cold), IEC 60068-2-2 (Test Bd, Operating Dry Heat), IEC 60068-2-14 (Test Nb, Operating Thermal Shock)	0 °C < Ta < +60 °C (+32 °F < Ta < +140 °F)
Temperature, surrounding air, max	60 °C (140 °F)
Temperature, nonoperating IEC 60068-2-1 (Test Ab, Unpackaged Nonoperating Cold), IEC 60068-2-2 (Test Bb, Unpackaged Nonoperating Dry Heat), IEC 60068-2-14 (Test N/A, Unpackaged Nonoperating Thermal Shock)	-40...+85 °C (-40...+185 °F)
Relative humidity IEC 60068-2-30 (Test dB, Unpackaged Damp Heat)	5...95% noncondensing
Vibration IEC 60068-2-6 (Test Fc, Operating)	2 g @ 10...500 Hz
Shock, operating IEC 60068-2-27 (Test Ea, Unpackaged Shock)	30 g
Shock, nonoperating IEC 60068-2-27 (Test Ea, Unpackaged Shock)	50 g
Emissions	IEC 61000-6-4
ESD immunity IEC 61000-4-2	6 kV contact discharges 8 kV air discharges



**Environmental Specifications - 1756-IF16, 1756-IF16K**

Attribute	1756-IF16, 1756-IF16K
Radiated RF immunity IEC 61000-4-3	10V/m with 1 kHz sine-wave 80% AM from 80...2000 MHz 10V/m with 200 Hz 50% Pulse 100% AM @ 900 MHz 10V/m with 200 Hz 50% Pulse 100% AM @ 1890 MHz 3V/m with 1 kHz sine-wave 80% AM from 2000...2700 MHz
EFT/B immunity IEC 61000-4-4	±2 kV at 5 kHz on signal ports
Surge transient immunity IEC 61000-4-5	±2 kV line-earth (CM) on shielded ports
Conducted RF immunity IEC 61000-4-6	10V rms with 1 kHz sine-wave 80% AM from 150 kHz...80 MHz

**Certifications - 1756-IF16, 1756-IF16K**

Certification (when product is marked) <sup>(1)</sup>	1756-IF16, 1756-IF16K
UL	UL Listed Industrial Control Equipment. See UL File E65584.
CSA	CSA Certified Process Control Equipment. See CSA File LR54689C. CSA Certified Process Control Equipment for Class I, Division 2 Group A,B,C,D Hazardous Locations. See CSA File LR69960C.
FM	FM Approved Equipment for use in Class I Division 2 Group A,B,C,D Hazardous Locations
CE	European Union 2014/30/EU EMC Directive, compliant with: <ul style="list-style-type: none"> <li>EN 61326-1; Meas./Control/Lab., Industrial Requirements</li> <li>EN 61000-6-2; Industrial Immunity</li> <li>EN 61000-6-4; Industrial Emissions</li> <li>EN 61131-2; Programmable Controllers (Clause 8, Zone A &amp; B)</li> </ul> European Union 2014/35/EU LVD, compliant with: EN 61131-2; Programmable Controllers (Clause 11)
RCM	Australian Radiocommunications Act, compliant with: EN 61000-6-4; Industrial Emissions
Ex	European Union 2014/34/EU ATEX Directive, compliant with: <ul style="list-style-type: none"> <li>EN 60079-0; General Requirements</li> <li>EN 60079-15; Potentially Explosive Atmospheres, Protection "n"</li> <li>II 3 G Ex nA IICT4 Gc</li> <li>DEMKO15ATEX1482X</li> </ul>
IECEx	IECEx System, compliant with: <ul style="list-style-type: none"> <li>IEC 60079-0; General Requirements</li> <li>IEC 60079-15; Potentially Explosive Atmospheres, Protection "n"</li> <li>II 3 G Ex nA IICT4 Gc</li> <li>IECEx UL 15.0053X</li> </ul>
KC	Korean Registration of Broadcasting and Communications Equipment, compliant with: Article 58-2 of Radio Waves Act, Clause 3
EAC	Russian Customs Union TR CU 020/2011 EMC Technical Regulation Russian Customs Union TR CU 004/2011 LV Technical Regulation

(1) See the Product Certification link at [rok.auto/certifications](http://rok.auto/certifications) for Declarations of Conformity, Certificates, and other certification details.

## 1756-IF16H, 1756-IF16HK

ControlLogix current analog input module with HART protocol.

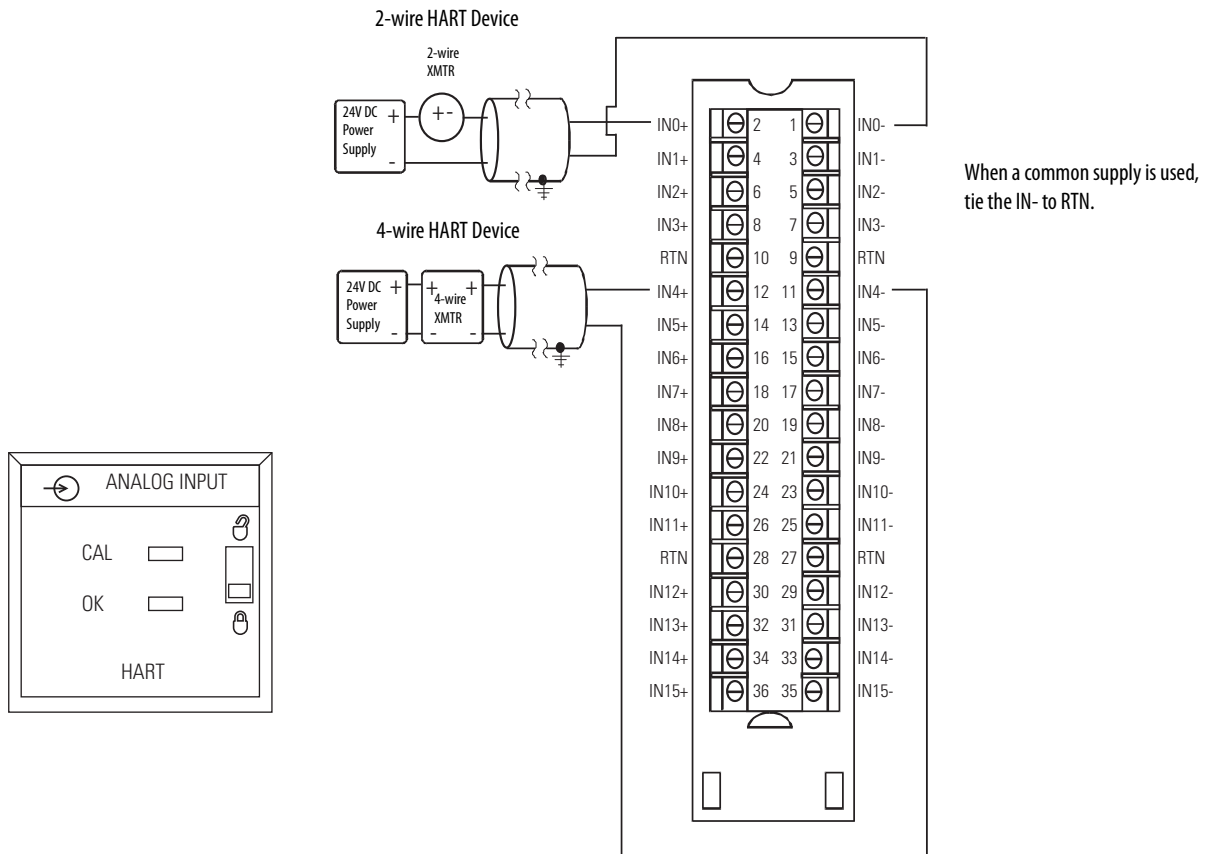

### Technical Specifications - 1756-IF16H, 1756-IF16HK

Attribute	1756-IF16H, 1756-IF16HK
Inputs	Sixteen differential, current Dedicated HART modem per channel
Input range	0...20 mA 4...20 mA
Resolution	16...21 bits
Voltage and current ratings	Backplane: 5.1V DC @ 200 mA, 24V DC @ 125 mA Input current range: 0...20 mA, 4...20 mA
Total backplane power	4.02 W
Power dissipation, max	6 W
Isolation voltage	50V (continuous), Basic insulation type, Input Channels to Backplane No isolation between individual Input Channels
Thermal dissipation	12 BTU/hr
Input impedance	249 $\Omega$
Open circuit detection time	Positive full scale reading within 5 s
Oversvoltage protection, max	8V DC

**Technical Specifications - 1756-IF16H, 1756-IF16HK**

Attribute	1756-IF16H, 1756-IF16HK
Normal mode noise rejection	74 dB @ 50/60 Hz (15 Hz filter) 90 dB @ 60 Hz (20 Hz filter)
Common mode noise rejection	> 90 dB @ 50/60 Hz (15 Hz and 20 Hz filters only)
Repeatability	Better than 0.01% of range (15 Hz and 20 Hz filters only)
Calibrated accuracy	Better than 0.13% of range (all filters)
Calibration interval	12 months typical
Offset drift	27 $\mu\text{V}/^\circ\text{C}$
Gain drift with temperature	11 ppm/ $^\circ\text{C}$
Module error	0.3% of range
Module input scan time, min	11...328 ms (filter dependent)
Module HART scan time	Estimate 1 s if all channels are HART enabled
Data format	Integer mode (left justified, 2 s complement) IEEE 32-bit floating point
Input conversion method	Successive approximation
Output conversion method	R-Ladder DAC, monotonicity with no missing codes
Module keying	Electronic, software configurable
Removable terminal block	1756-TBCH 1756-TBS6H
RTB keying	User-defined mechanical
Slot width	1
Wire size	1756-TBCH Single wire connection: 0.33...2.1 mm <sup>2</sup> (22...14 AWG) solid or stranded shielded copper wire, rated at 105 °C (221 °F) or greater, 1.2 mm (3/64 in.) insulation max  1756-TBS6H Single wire connection: 0.33...2.1 mm <sup>2</sup> (22...14 AWG) solid or stranded shielded copper wire, rated at 105 °C (221 °F) or greater, 1.2 mm (3/64 in.) insulation max
Terminal block torque spec	1756-TBCH 0.5 N·m (4.4 lb·in)
Wire category <sup>(1)</sup>	2 - on signal ports
Wire type	Copper
Enclosure type rating	None (open-style)
North American temp code	T5
ATEX temp code	T4
IECEx temp code	T4

(1) Use this Conductor Category information for planning conductor routing. See the Industrial Automation Wiring and Grounding Guidelines, publication [1770-4.1](#).

**Environmental Specifications - 1756-IF16H, 1756-IF16HK**

<b>Attribute</b>	<b>1756-IF16H, 1756-IF16HK</b>
Temperature, operating IEC 60068-2-1 (Test Ad, Operating Cold), IEC 60068-2-2 (Test Bd, Operating Dry Heat), IEC 60068-2-14 (Test Nb, Operating Thermal Shock)	0 °C < Ta < +60 °C (+32 °F < Ta < +140 °F)
Temperature, surrounding air, max	60 °C (140 °F)
Temperature, nonoperating IEC 60068-2-1 (Test Ab, Unpackaged Nonoperating Cold), IEC 60068-2-2 (Test Bb, Unpackaged Nonoperating Dry Heat), IEC 60068-2-14 (Test N/A, Unpackaged Nonoperating Thermal Shock)	-40...+85 °C (-40...+185 °F)
Relative humidity IEC 60068-2-30 (Test dB, Unpackaged Damp Heat)	5...95% noncondensing
Vibration IEC 60068-2-6 (Test Fc, Operating)	2 g @ 10...500 Hz
Shock, operating IEC 60068-2-27 (Test Ea, Unpackaged Shock)	30 g
Shock, nonoperating IEC 60068-2-27 (Test Ea, Unpackaged Shock):	50 g
Emissions	IEC 61000-6-4
ESD immunity IEC 61000-4-2	6 kV contact discharges 8 kV air discharges
Radiated RF immunity IEC 61000-4-3	10V/m with 1 kHz sine-wave 80% AM from 80...2000 MHz 10V/m with 200 Hz 50% Pulse 100% AM @ 900 MHz 10V/m with 200 Hz 50% Pulse 100% AM @ 1890 MHz 1V/m with 1 kHz sine-wave 80% AM from 2000...2700 MHz
EFT/B immunity IEC 61000-4-4	±2 kV at 5 kHz on signal ports
Surge transient immunity IEC 61000-4-5	±2 kV line-earth (CM) on shielded ports
Conducted RF immunity IEC 61000-4-6	10V rms with 1 kHz sine-wave 80% AM from 150 kHz...80 MHz

**Certifications - 1756-IF16H, 1756-IF16HK**

<b>Certification (when product is marked)<sup>(1)</sup></b>	<b>1756-IF16H, 1756-IF16HK</b>
c-UL-us	UL Listed Industrial Control Equipment, certified for US and Canada. See UL File E65584. UL Listed for Class I, Division 2 Group A,B,C,D Hazardous Locations, certified for U.S. and Canada. See UL File E194810.
CE	European Union 2014/30/EU EMC Directive, compliant with: <ul style="list-style-type: none"> <li>• EN 61326-1; Meas./Control/Lab., Industrial Requirements</li> <li>• EN 61000-6-2; Industrial Immunity</li> <li>• EN 61000-6-4; Industrial Emissions</li> <li>• EN 61131-2; Programmable Controllers (Clause 8, Zone A &amp; B)</li> </ul>
RCM	Australian Radiocommunications Act, compliant with: <ul style="list-style-type: none"> <li>• EN 61000-6-4; Industrial Emissions</li> </ul>
Ex	European Union 2014/34/EU ATEX Directive, compliant with: <ul style="list-style-type: none"> <li>• EN 60079-0; General Requirements</li> <li>• EN 60079-15; Potentially Explosive Atmospheres, Protection "n"</li> <li>• II 3 G Ex nA IIC T4 Gc</li> <li>• DEMKO12ATEX1219040X</li> </ul>
IECEX	IECEX System, compliant with: <ul style="list-style-type: none"> <li>• IEC 60079-0; General Requirements</li> <li>• IEC 60079-15; Potentially Explosive Atmospheres, Protection "n"</li> <li>• II 3 G Ex nA IIC T4 Gc</li> <li>• IECEX UL 16.0109X</li> </ul>
KC	Korean Registration of Broadcasting and Communications Equipment, compliant with: Article 58-2 of Radio Waves Act, Clause 3
EAC	Russian Customs Union TR CU 020/2011 EMC Technical Regulation Russian Customs Union TR CU 004/2011 LV Technical Regulation

(1) See the Product Certification link at [rok.auto/certifications](http://rok.auto/certifications) for Declarations of Conformity, Certificates, and other certification details.

## 1756-IF16IH, 1756-IF16HK

ControlLogix current analog input module with HART protocol

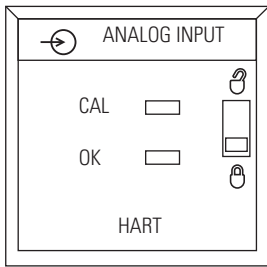
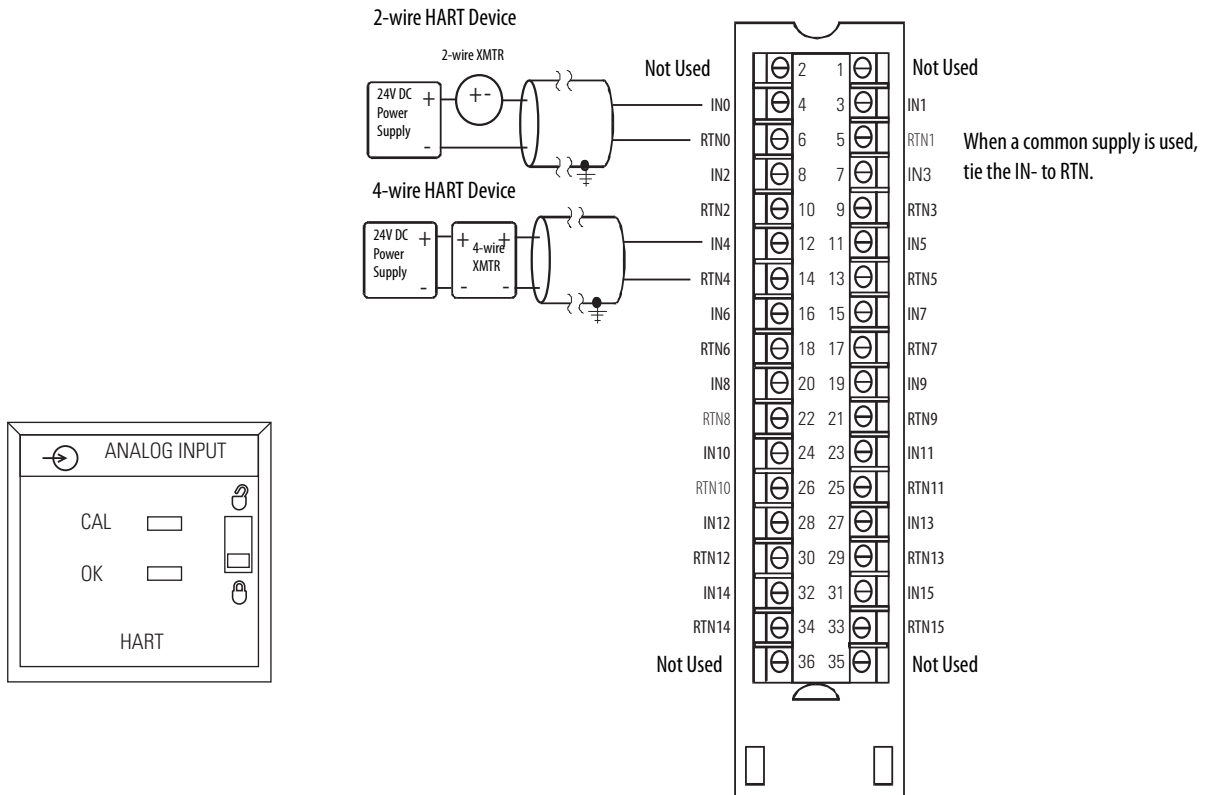

### Technical Specifications - 1756-IF16IH, 1756-IF16HK

Attribute	1756-IF16IH, 1756-IF16HK
Voltage and current ratings	Backplane: 225 mA @ 5.1V DC, 200 mA @ 24V DC 16 Inputs Input current range: 0...20 mA, 4...20 mA
Resolution	16...21 bits
Power dissipation	5.30 W
Inrush current	400 mA @ 5.1V DC 450 mA @ 24V DC
Isolation voltage	250V (continuous) Reinforced Insulation Type, inputs to backplane. Basic Insulation Type, input to input, and inputs to ground
Input impedance	250 Ω (±5 Ω)
Open circuit detection time	5 s, 4...20 mA range only
Input overvoltage protection	28.8V DC
Normal mode noise rejection	90 dB @ 50/60 Hz (10 Hz filter) 74 dB @ 50/60 Hz (15 Hz filter) 33 dB @ 60 Hz, 90 dB @60 Hz (20 Hz filter)
Common mode noise rejection	> 90 dB @ 50/60 Hz (10 Hz, 15 Hz, and 20 Hz filters only)
Calibrated accuracy at 25 °C with HART disabled	0.15...1.5% of full scale, dependent on selected filter

**Technical Specifications - 1756-IF16IH, 1756-IF16IHK**

Attribute	1756-IF16IH, 1756-IF16IHK
Calibrated accuracy at 25 °C with HART enabled	1.5% of full scale with 250 Hz filter 0.5% of full scale with 100 Hz filter 0.2% of full scale with 50 Hz or 60 Hz filter 0.15% of full scale with 15 Hz or 20 Hz filter Monotonicity not guaranteed
Calibrated accuracy over full temperature range with HART enabled	1.8% of full scale with 250 Hz filter 0.8% of full scale with 100 Hz filter 0.5% of full scale with 50 Hz or 60 Hz filter 0.4% of full scale with 15 Hz or 20 Hz filter Monotonicity not guaranteed
Calibration interval	12 months typical
Input offset drift with temperature	300 $\mu$ A/°C
Gain drift with temperature	20 ppm/°C
Module error over full temperature range with HART disabled	0.3% of range (all filters)
Module scan time for all channels - analog, min	14...428 ms (filter dependent)
Typical module HART dynamic variables update time for all channels	1 s typical with no pass through or device information messaging active
Data format	Integer mode (left justified, 2 s complement) IEEE 32-bit floating point
Input conversion method	Sigma-Delta ADC (24-bit converter)
Output conversion method	Sigma-Delta ADC (24-bit converter)
Module keying	ASIC does not support module keying
Removable terminal block	1756-TBCH 1756-TBS6H
RTB keying	User-defined mechanical
Slot width	1
Wire size	1756-TBCH Single wire connection: 0.33...2.1 mm <sup>2</sup> (22...14 AWG) solid or stranded shielded copper wire, rated at 105 °C (221 °F) or greater, 1.2 mm (3/64 in.) insulation max  1756-TBS6H Single wire connection: 0.33...2.1 mm <sup>2</sup> (22...14 AWG) solid or stranded shielded copper wire, rated at 105 °C (221 °F) or greater, 1.2 mm (3/64 in.) insulation max
Terminal block torque specs	1756-TBCH 0.5 N•m (4.4 lb-in)
Wiring category <sup>(1)</sup>	2 - on signal ports
Wire type	Copper
Enclosure type rating	None (open-style)
North American temp code	T5
ATEX temp code	T4
IECEx temp code	T4

(1) Use this conductor category information for planning conductor routing. See Industrial Automation Wiring and Grounding Guidelines, publication [1770-4.1](#).

**Environmental Specifications - 1756-IF16IH, 1756-IF16IHK**

<b>Attribute</b>	<b>1756-IF16IH, 1756-IF16IHK</b>
Temperature, operating IEC 60068-2-1 (Test Ad, Operating Cold), IEC 60068-2-2 (Test Bd, Operating Dry Heat), IEC 60068-2-14 (Test Nb, Operating Thermal Shock)	0 °C < Ta < +60 °C (+32 °F < Ta < +140 °F)
Temperature, surrounding air, max	60 °C (140 °F)
Temperature, nonoperating IEC 60068-2-1 (Test Ab, Unpackaged Nonoperating Cold), IEC 60068-2-2 (Test Bb, Unpackaged Nonoperating Dry Heat), IEC 60068-2-14 (Test N/A, Unpackaged Nonoperating Thermal Shock)	-40...+85 °C (-40...+185 °F)
Relative humidity IEC 60068-2-30 (Test dB, Unpackaged Damp Heat)	5...95% noncondensing
Vibration IEC 60068-2-6 (Test Fc, Operating)	2 g @ 10...500 Hz
Shock, operating IEC 60068-2-27 (Test Ea, Unpackaged Shock)	30 g
Shock, nonoperating IEC 60068-2-27 (Test Ea, Unpackaged Shock)	50 g
Emissions	IEC 61000-6-4
ESD immunity IEC 61000-4-2	6 kV contact discharges 8 kV air discharges
Radiated RF immunity IEC 61000-4-3	10V/m with 1 kHz sine-wave 80% AM from 80...2000 MHz 10V/m with 200 Hz 50% Pulse 100% AM @ 900 MHz 10V/m with 200 Hz 50% Pulse 100% AM @ 1890 MHz 3V/m with 1 kHz sine-wave 80% AM from 2000...6000 MHz
EFT/B immunity IEC 61000-4-4	±2 kV at 5 kHz on signal ports
Surge transient immunity IEC 61000-4-5	±2 kV line-earth (CM) on shielded ports
Conducted RF immunity IEC 61000-4-6	10V rms with 1 kHz sine-wave 80% AM from 150 kHz...80 MHz



**Certifications - 1756-IF16IH, 1756-IF16IHK**

<b>Certification (when product is marked)<sup>(1)</sup></b>	<b>1756-IF16IH, 1756-IF16IHK</b>
c-UL-us	UL Listed Industrial Control Equipment, certified for US and Canada. See UL File E65584. UL Listed for Class I, Division 2 Group A,B,C,D Hazardous Locations, certified for U.S. and Canada. See UL File E194810.
CE	European Union 2014/30/EU EMC Directive, compliant with: <ul style="list-style-type: none"> <li>• EN 61326-1; Meas./Control/Lab., Industrial Requirements</li> <li>• EN 61000-6-2; Industrial Immunity</li> <li>• EN 61000-6-4; Industrial Emissions</li> <li>• EN 61131-2; Programmable Controllers (Clause 8, Zone A &amp; B)</li> </ul> European Union 2014/35/EU LVD, compliant with: <ul style="list-style-type: none"> <li>• EN 61131-2; Programmable Controllers (Clause 11)</li> </ul>
RCM	Australian Radiocommunications Act, compliant with: <ul style="list-style-type: none"> <li>• EN 61000-6-4; Industrial Emissions</li> </ul>
Ex	European Union 2014/34/EU ATEX Directive, compliant with: <ul style="list-style-type: none"> <li>• EN 60079-0; General Requirements</li> <li>• EN 60079-15; Potentially Explosive Atmospheres, Protection "n"</li> <li>• II 3 G Ex nA IIC T4 Gc</li> <li>• DEMKO14ATEX1238X</li> </ul>
IECEX	IECEX System, compliant with: <ul style="list-style-type: none"> <li>• IEC 60079-0; General Requirements</li> <li>• IEC 60079-15; Potentially Explosive Atmospheres, Protection "n"</li> <li>• II 3 G Ex nA IIC T4 Gc</li> <li>• IECEX UL 16.0110X</li> </ul>
KC	Korean Registration of Broadcasting and Communications Equipment, compliant with: Article 58-2 of Radio Waves Act, Clause 3
EAC	Russian Customs Union TR CU 020/2011 EMC Technical Regulation Russian Customs Union TR CU 004/2011 LV Technical Regulation

(1) See the Product Certification link at [rok.auto/certifications](http://rok.auto/certifications) for Declarations of Conformity, Certificates, and other certification details.

# 1756-IG16

## ControlLogix TTL input module

Standard Wiring

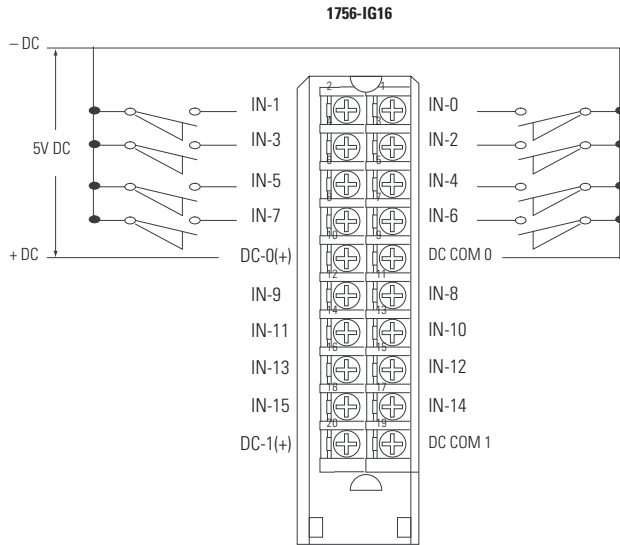

CE Compliant Wiring

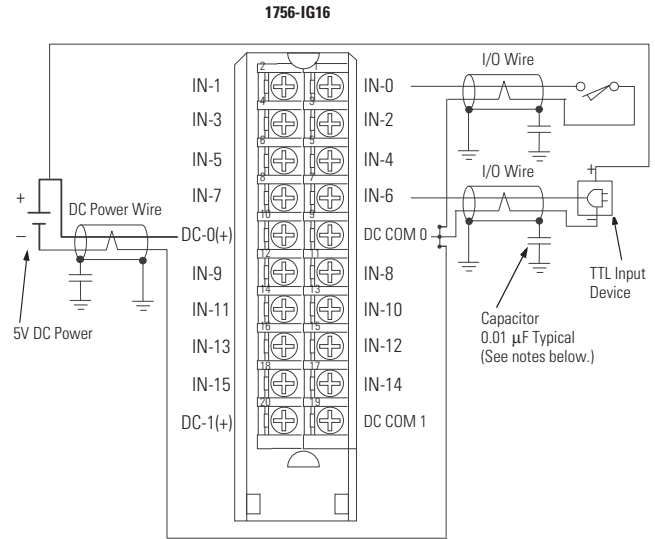

Simplified Schematic

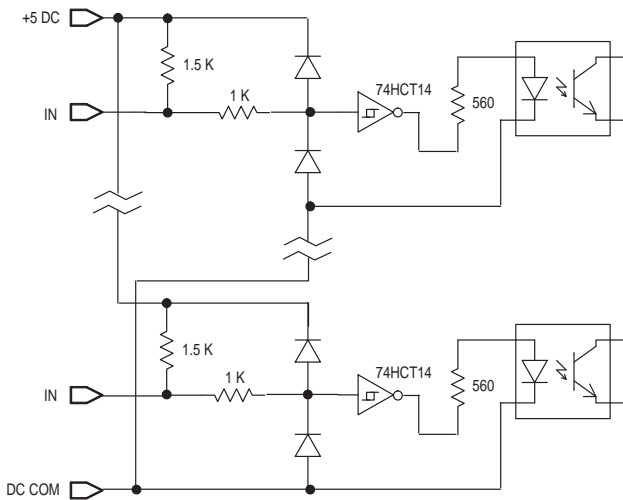

**IMPORTANT:** I/O cables must be shielded type and cable length must be <10 m (32.8 ft) for maximum EMI noise immunity.

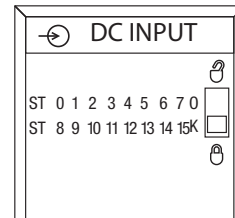

### Low to True Format - 1756-IG16

- -0.2...0.8V = Input guaranteed to be in on-state
- 0.8...2.0V = Input state not guaranteed
- 2.0...5.5V = Input guaranteed to be in off-state

**Technical Specifications - 1756-IG16**

Attribute	1756-IG16
Inputs	16 (8 points/group)
Voltage category	5V DC TTL source (Low=True) <sup>(1)</sup>
Operating voltage range	4.5...5.5V DC 50 mV P-P ripple max
Input delay time (screw to backplane) Off to On (5-to-0V DC transition)	Hardware delay: 270 $\mu$ s nom/450 $\mu$ s max + filter time User-selectable filter time: 0 ms, 1 ms, or 2 ms
On to Off (0-to-5V DC transition)	Hardware delay: 390 $\mu$ s nom/ 700 $\mu$ s max + filter time User-selectable filter time: 0 ms, 1 ms, 2 ms, 9 ms, or 18 ms
Current draw @ 5.1V	110 mA
Current draw @ 24V	2 mA
Total backplane power	0.61 W
Power dissipation, max	1.4 W @ 60 °C (140 °F)
Thermal dissipation	4.8 BTU/hr @ 60 °C (140 °F)
Off-state voltage, max	2V
Off-state current, max	4.1 mA
Input impedance, max	1.4 k $\Omega$ min 1.5 k $\Omega$ typical
Input current, nom	3.7 mA @ 5V DC
Input current, max	4.1 mA @ 5V DC
Cyclic update time	200 $\mu$ s...750 ms
Change of state	Software configurable
Time stamp of inputs	$\pm$ 200 $\mu$ s
Isolation voltage	250V (continuous), basic insulation type, inputs-to-backplane, and input group-to-group No isolation between individual group inputs
Module keying	Electronic, software configurable
Removable terminal block housing	1756-TBNH 1756-TBSH
RTB keying	User-defined mechanical
Slot width	1
Wire category	2 <sup>(2)</sup>
Enclosure type	None (open-style)
North American temperature code	T5
IEC temperature code	T5
Reverse polarity protection	No

(1) TTL inputs are inverted (-0.2 to +0.8 = low voltage = True = On.) Use a NOT instruction in your program to convert to traditional True - High logic.

(2) Use this conductor category information for planning conductor routing as described in the system-level installation manual. See the Industrial Automation Wiring and Grounding Guidelines, publication [1770-4.1](#).

**Environmental Specifications - 1756-IG16**

Attribute	1756-IG16
Temperature, operating IEC 60068-2-1 (Test Ad, Operating Cold), IEC 60068-2-2 (Test Bd, Operating Dry Heat), IEC 60068-2-14 (Test Nb, Operating Thermal Shock)	0...60 °C (32...140 °F)
Temperature, surrounding air, max	60 °C (140 °F)
Temperature, nonoperating IEC 60068-2-1 (Test Ab, Unpackaged Nonoperating Cold), IEC 60068-2-2 (Test Bb, Unpackaged Nonoperating Dry Heat), IEC 60068-2-14 (Test N/A, Unpackaged Nonoperating Thermal Shock)	-40...+85 °C (-40...+185 °F)
Relative humidity IEC 60068-2-30 (Test dB, Unpackaged Damp Heat)	5...95% noncondensing
Vibration IEC 60068-2-6 (Test Fc, Operating)	2 g @ 10...500 Hz
Shock, operating IEC 60068-2-27 (Test Ea, Unpackaged Shock)	30 g
Shock, nonoperating IEC 60068-2-27 (Test Ea, Unpackaged Shock)	50 g
Emissions	IEC 61000-6-4
ESD immunity IEC 61000-4-2	6 kV contact discharges 8 kV air discharges
Radiated RF immunity IEC 61000-4-3	10V/m with 1 kHz sine-wave 80% AM from 80...2000 MHz 10V/m with 200 Hz 50% Pulse 100% AM @ 900 MHz 10V/m with 200 Hz 50% Pulse 100% AM @ 1890 MHz 3V/m with 1 kHz sine-wave 80% AM from 2000...2700 MHz
EFT/B immunity IEC 61000-4-4	±1 kV at 5 kHz on signal ports
Conducted RF immunity IEC 61000-4-6	10V rms with 1 kHz sine-wave 80% AM from 150 kHz...80 MHz

**Certifications - 1756-IG16**

Certification (when product is marked) <sup>(1)</sup>	1756-IG16
UL	UL Listed Industrial Control Equipment. See UL File E65584.
CSA	CSA Certified Process Control Equipment. See CSA File LR54689C. CSA Certified Process Control Equipment for Class 1, Division 2 Group A,B,C,D Hazardous Locations. See CSA File LR69960C.
CE	European Union 2014/30/EU EMC Directive, compliant with: <ul style="list-style-type: none"> <li>EN 61326-1; Meas./Control/Lab., Industrial Requirements</li> <li>EN 61000-6-2; Industrial Immunity</li> <li>EN 61000-6-4; Industrial Emissions</li> <li>EN 61131-2; Programmable Controllers (Clause 8, Zone A &amp; B)</li> </ul> European Union 2014/35/EU LVD, compliant with: EN 61131-2; Programmable Controllers (Clause 11)
RCM	Australian Radiocommunications Act, compliant with: EN 61000-6-4; Industrial Emissions
Ex	European Union 2014/34/EU ATEX Directive, compliant with: <ul style="list-style-type: none"> <li>EN 60079-15; Potentially Explosive Atmospheres, Protection "n"</li> <li>EN 60079-0; General Requirements II 3 G Ex nA IIC T5 X Gc</li> </ul>
KC	Korean Registration of Broadcasting and Communications Equipment, compliant with: Article 58-2 of Radio Waves Act, Clause 3
EAC	Russian Customs Union TR CU 020/2011 EMC Technical Regulation Russian Customs Union TR CU 004/2011 LV Technical Regulation

(1) See the Product Certification link at [rok.automation.com/certifications](http://rok.automation.com/certifications) for Declarations of Conformity, Certificates, and other certification details.

# 1756-IH16I

ControlLogix 125V DC isolated input module

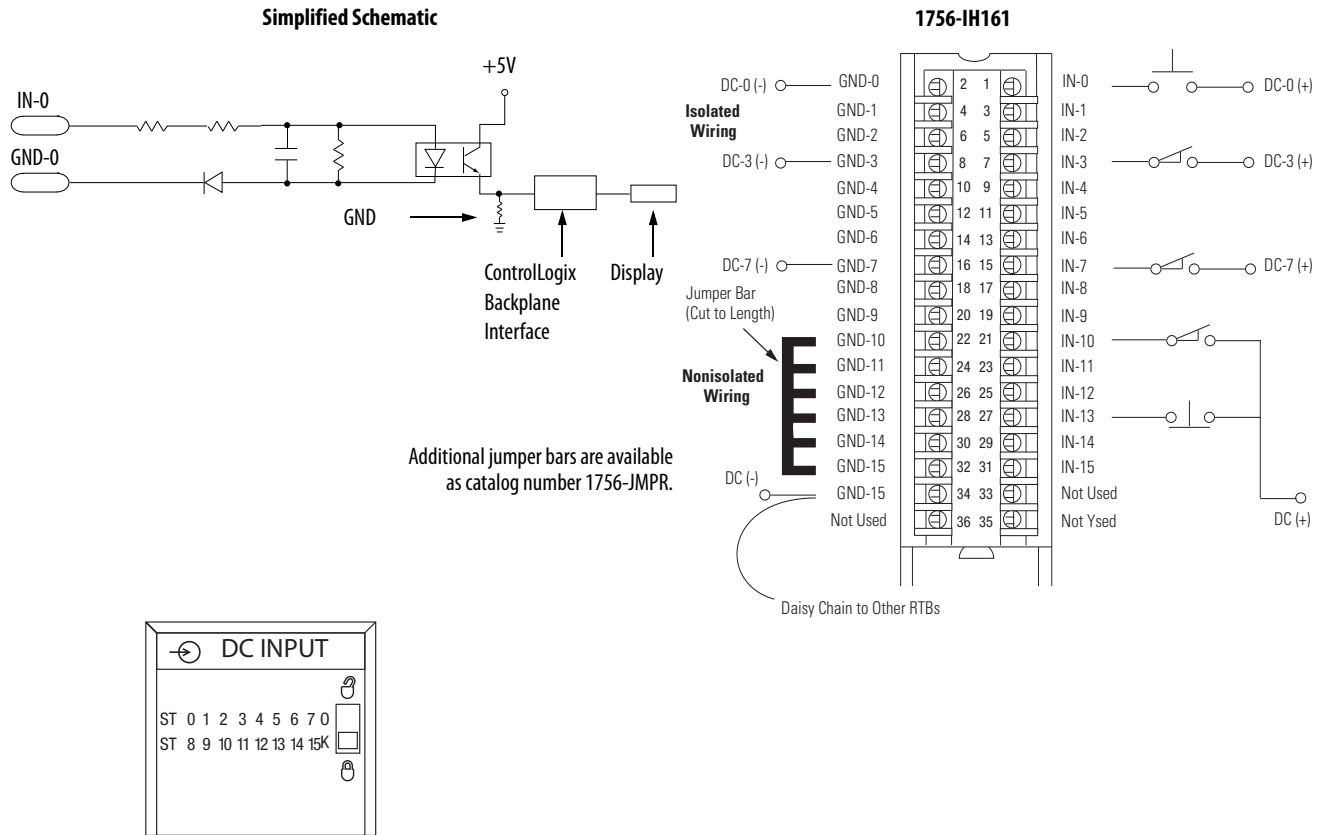

## Technical Specifications - 1756-IH16I

Attribute	1756-IH16I
Inputs	16 individually isolated
Voltage category	125V DC sink/source
Operating voltage range	90...146V DC <sup>(1)</sup>
Input voltage, nom	125V DC
Input delay time (screw to backplane)	Hardware delay: 2 ms max + filter time User-selectable filter time: 0 ms, 1 ms, or 2 ms Hardware delay: 6 ms max + filter time User-selectable filter time: 0 ms, 1 ms, 2 ms, 9 ms, or 18 ms
Off to On	
On to Off	
Current draw @ 5.1V	125 mA
Current draw @ 24V	3 mA
Total backplane power	0.71 W
Power dissipation, max	5 W @ 60 °C (140 °F)
Thermal dissipation	17.05 BTU/hr
Off-state voltage, max	20V DC

**Technical Specifications - 1756-IH16I (continued)**

Attribute	1756-IH16I
Off-state current, max	0.8 mA
On-state current, min	1 mA @ 90V DC
On-state current, max	3 mA @ 146V DC
On-state voltage Derated as follows	90...146V DC 90...146V DC @ 50 °C (122 °F), 12 Channels ON 90...132V DC @ 55 °C (131 °F), 14 Channels ON 90...125V DC @ 60 °C (140 °F), 16 Channels ON 90...146V DC @ 30 °C (86 °F), 16 Channels ON
Inrush current, max	250 mA
Input impedance, max	48.67 k $\Omega$ @ 146V DC
Cyclic update time	200 $\mu$ s...750 ms
Change of state	Software configurable
Time stamp of inputs	$\pm$ 200 $\mu$ s
Isolation voltage	250V (continuous), basic insulation type, inputs-to-backplane, and input-to-input
Module keying	Electronic, software configurable
Removable terminal block housing	1756-TBCH 1756-TBS6H
RTB keying	User-defined mechanical
Slot width	1
Wire category	1 <sup>(2)</sup>
Enclosure type	None (open-style)
North American temperature code	T4
Reverse polarity protection	Yes

(1) UL certification for 125V nominal. Rockwell Automation specified to the following:

- 90...146V DC @ 50 °C (122 °F), 12 channels on
- 90...132V DC @ 55 °C (131 °F), 14 channels on
- 90...125V DC @ 60 °C (140 °F), 16 channels on
- 90...146V DC @ 30 °C (86 °F), 16 channels on.

(2) Use this conductor category information for planning conductor routing as described in the system-level installation manual. See the Industrial Automation Wiring and Grounding Guidelines, publication [1770-4.1](#).

**Environmental Specifications - 1756-IH16I**

Attribute	1756-IH16I
Temperature, operating IEC 60068-2-1 (Test Ad, Operating Cold), IEC 60068-2-2 (Test Bd, Operating Dry Heat), IEC 60068-2-14 (Test Nb, Operating Thermal Shock)	0...60 °C (32...140 °F)
Temperature, surrounding air, max	60 °C (140 °F)
Temperature, nonoperating IEC 60068-2-1 (Test Ab, Unpackaged Nonoperating Cold), IEC 60068-2-2 (Test Bb, Unpackaged Nonoperating Dry Heat), IEC 60068-2-14 (Test N/A, Unpackaged Nonoperating Thermal Shock)	-40...+85 °C (-40...+185 °F)
Relative humidity IEC 60068-2-30 (Test dB, Unpackaged Damp Heat)	5...95% noncondensing
Vibration IEC 60068-2-6 (Test Fc, Operating)	2 g @ 10...500 Hz

**Environmental Specifications - 1756-IH161 (continued)**

Attribute	1756-IH161
Shock, operating IEC 60068-2-27 (Test Ea, Unpackaged Shock)	30 g
Shock, nonoperating IEC 60068-2-27 (Test Ea, Unpackaged Shock)	50 g
Emissions	IEC 61000-6-4
ESD immunity IEC 61000-4-2	6 kV contact discharges 8 kV air discharges
Radiated RF immunity IEC 61000-4-3	10V/m with 1 kHz sine-wave 80% AM from 80...2000 MHz 10V/m with 200 Hz 50% Pulse 100% AM @ 900 MHz 10V/m with 200 Hz 50% Pulse 100% AM @ 1890 MHz 3V/m with 1 kHz sine-wave 80% AM from 2000...2700 MHz
EFT/B immunity IEC 61000-4-4	±4 kV at 5 kHz on signal ports
Surge transient immunity IEC 61000-4-5	±1 kV line-line (DM) and ±2 kV line-earth (CM) on signal ports
Conducted RF immunity IEC 61000-4-6	10V rms with 1 kHz sine-wave 80% AM from 150 kHz...80 MHz
Oscillatory surge withstand IEEE C37.90.1	3 kV

**Certifications - 1756-IH161**

Certification (when product is marked) <sup>(1)</sup>	1756-IH161
UL	UL Listed Industrial Control Equipment. See UL File E65584.
CSA	CSA Certified Process Control Equipment. See CSA File LR54689C. CSA Certified Process Control Equipment for Class I, Division 2 Group A,B,C,D Hazardous Locations. See CSA File LR69960C.
CE	European Union 2014/30/EU EMC Directive, compliant with: <ul style="list-style-type: none"> <li>EN 61326-1; Meas./Control/Lab., Industrial Requirements</li> <li>EN 61000-6-2; Industrial Immunity</li> <li>EN 61000-6-4; Industrial Emissions</li> <li>EN 61131-2; Programmable Controllers (Clause 8, Zone A &amp; B)</li> </ul> European Union 2014/35/EU LVD, compliant with: EN 61131-2; Programmable Controllers (Clause 11)
RCM	Australian Radiocommunications Act, compliant with: EN 61000-6-4; Industrial Emissions
FM	FM Approved Equipment for use in Class I Division 2 Group A,B,C,D Hazardous Locations
KC	Korean Registration of Broadcasting and Communications Equipment, compliant with: Article 58-2 of Radio Waves Act, Clause 3
EAC	Russian Customs Union TR CU 020/2011 EMC Technical Regulation Russian Customs Union TR CU 004/2011 LV Technical Regulation

(1) See the Product Certification link at [rok.auto/certifications](http://rok.auto/certifications) for Declarations of Conformity, Certificates, and other certification details.

# 1756-IH16ISOE

ControlLogix DC (90...140V) sequence of events input module

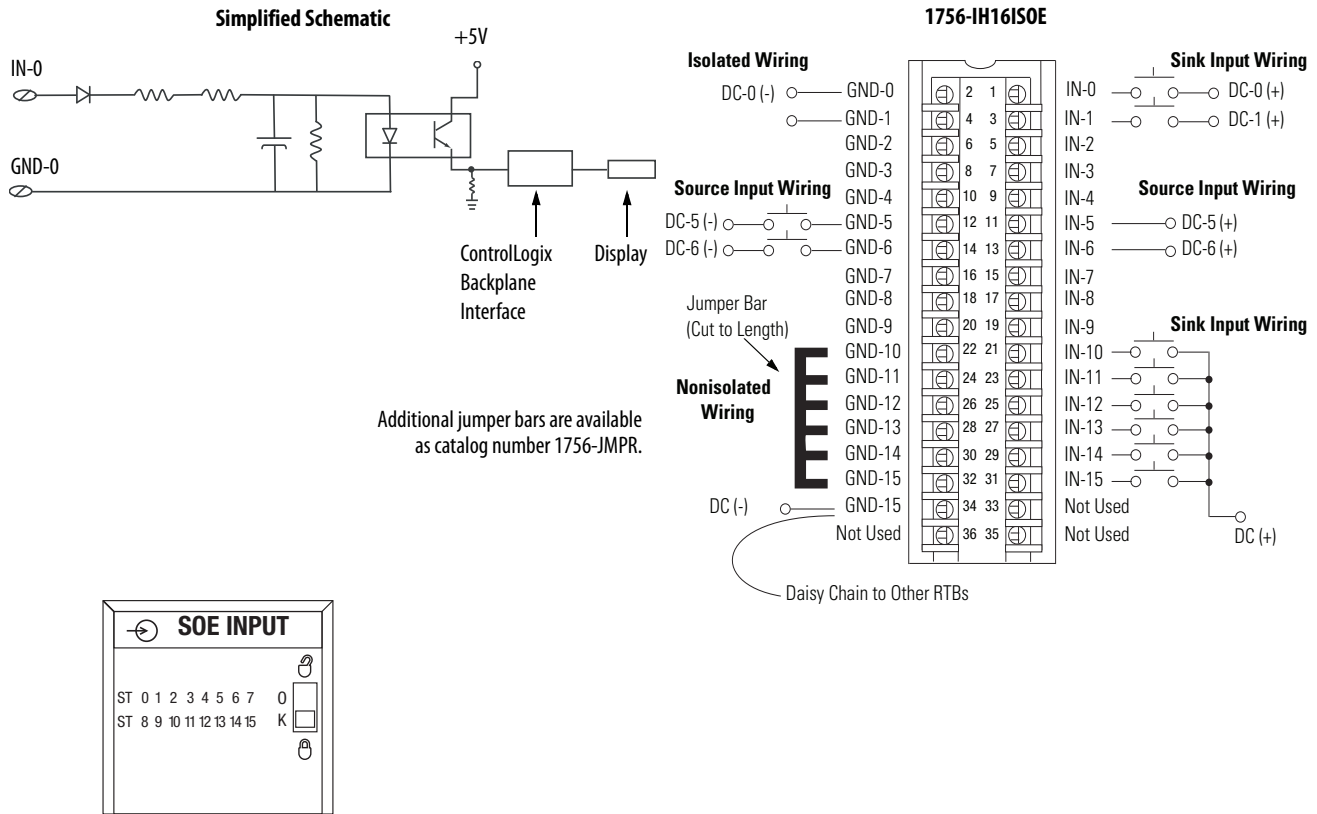

## Technical Specifications - 1756-IH16ISOE

Attribute	1756-IH16ISOE
Inputs	16 individually isolated, sequence of events
Voltage category	125V DC sink/source
Operating voltage range	90...140V DC
Input voltage, nom	125V DC
Input delay time (screw to backplane) Off to On	Hardware delay: 10 μs nom/20 μs max + firmware scan: up to 25 μs + filter time: 0...50 ms + ASIC delay: 175 μs (FIFO) or 625 μs (Coordinated System Time per point)
On to Off	Hardware delay: 50 μs nom/75 μs max + firmware scan: up to 25 μs + filter time: 0...50 ms + ASIC delay: 175 μs (FIFO) or 625 μs (Coordinated System Time per point)
Current draw @ 5.1V	275 mA $\bar{S}$
Current draw @ 24V	2 mA
Total backplane power	1.3 W
Power dissipation, max	5.5 W @ 60 °C (140 °F)



**Technical Specifications - 1756-IH16ISOE (continued)**

Attribute	1756-IH16ISOE
Thermal dissipation	17.22 BTU/hr
Off-state voltage, max	20V
Off-state current, max	0.3 mA
On-state current, min	1.15 mA @ 90V DC
On-state current, max	1.85 mA @ 140V DC
Input impedance, max	74.8 k $\Omega$
Cyclic update time	200 $\mu$ s...750 ms
Change of state	Software configurable
Time stamp of inputs	$\pm$ 100 $\mu$ s
Isolation voltage	250V (continuous), basic insulation type, inputs-to-backplane, and input-to-input
Module keying	Electronic, software configurable
Removable terminal block	1756-TBCH 1756-TBS6H
RTB keying	User-defined mechanical
Slot width	1
Wire category	1 <sup>(1)</sup>
Enclosure type	None (open-style)
North American temperature code	T3C
Reverse polarity protection	Yes

(1) Use this conductor category information for planning conductor routing as described in the system-level installation manual. See the Industrial Automation Wiring and Grounding Guidelines, publication [1770-4.1](#).

**Environmental Specifications - 1756-IH16ISOE**

Attribute	1756-IH16ISOE
Temperature, operating IEC 60068-2-1 (Test Ad, Operating Cold), IEC 60068-2-2 (Test Bd, Operating Dry Heat), IEC 60068-2-14 (Test Nb, Operating Thermal Shock)	0...60 °C (32...140 °F)
Temperature, surrounding air, max	60 °C (140 °F)
Temperature, nonoperating IEC 60068-2-1 (Test Ab, Unpackaged Nonoperating Cold), IEC 60068-2-2 (Test Bb, Unpackaged Nonoperating Dry Heat), IEC 60068-2-14 (Test N/A, Unpackaged Nonoperating Thermal Shock)	-40...+85 °C (-40...+185 °F)
Relative humidity IEC 60068-2-30 (Test dB, Unpackaged Damp Heat)	5...95% noncondensing
Vibration IEC 60068-2-6 (Test Fc, Operating)	2 g @ 10...500 Hz
Shock, operating IEC 60068-2-27 (Test Ea, Unpackaged Shock)	30 g
Shock, nonoperating IEC 60068-2-27 (Test Ea, Unpackaged Shock)	50 g
Emissions	IEC 61000-6-4
ESD immunity IEC 61000-4-2	6 kV contact discharges 8 kV air discharges

**Environmental Specifications - 1756-IH16ISOE (continued)**

Attribute	1756-IH16ISOE
Radiated RF immunity IEC 61000-4-3	10V/m with 1 kHz sine-wave 80% AM from 80 . . .2000 MHz 10V/m with 200 Hz 50% Pulse 100% AM @ 900 MHz 10V/m with 200 Hz 50% Pulse 100% AM @ 1890 MHz 3V/m with 1 kHz sine-wave 80% AM from 2000 . . .2700 MHz
EFT/B immunity IEC 61000-4-4	±4 kV at 5 kHz on signal ports
Surge transient immunity IEC 61000-4-5	±1 kV line-line (DM) and ±2 kV line-earth (CM) on signal ports
Conducted RF immunity IEC 61000-4-6	10V rms with 1 kHz sine-wave 80% AM from 150 kHz . . .80 MHz
Oscillatory surge withstand IEEE C37.90.1	3 kV

**Certifications - 1756-IH16ISOE**

Certification (when product is marked) <sup>(1)</sup>	1756-IH16ISOE
UL	UL Listed Industrial Control Equipment. See UL File E65584.
CSA	CSA Certified Process Control Equipment. See CSA File LR54689C. CSA Certified Process Control Equipment for Class I, Division 2 Group A,B,C,D Hazardous Locations. See CSA File LR69960C.
CE	European Union 2014/30/EU EMC Directive, compliant with: <ul style="list-style-type: none"> <li>• EN 61326-1; Meas./Control/Lab., Industrial Requirements</li> <li>• EN 61000-6-2; Industrial Immunity</li> <li>• EN 61000-6-4; Industrial Emissions</li> <li>• EN 61131-2; Programmable Controllers (Clause 8, Zone A &amp; B)</li> </ul> European Union 2014/35/EU LVD, compliant with: EN 61131-2; Programmable Controllers (Clause 11)
RCM	Australian Radiocommunications Act, compliant with: EN 61000-6-4; Industrial Emissions
KC	Korean Registration of Broadcasting and Communications Equipment, compliant with: Article 58-2 of Radio Waves Act, Clause 3
EAC	Russian Customs Union TR CU 020/2011 EMC Technical Regulation Russian Customs Union TR CU 004/2011 LV Technical Regulation

(1) See the Product Certification link at [rok.auto/certifications](http://rok.auto/certifications) for Declarations of Conformity, Certificates, and other certification details.

## 1756-IM16I, 1756-IM16IK

### ControlLogix 240V AC input module

Simplified Schematic

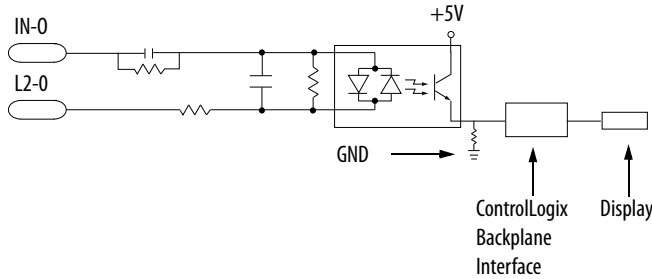

Additional jumper bars are available as catalog number 1756-JMPR.

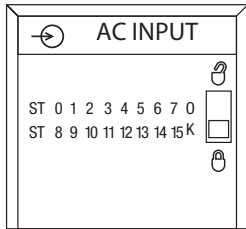

1756-IM16I, 1756-IM16IK

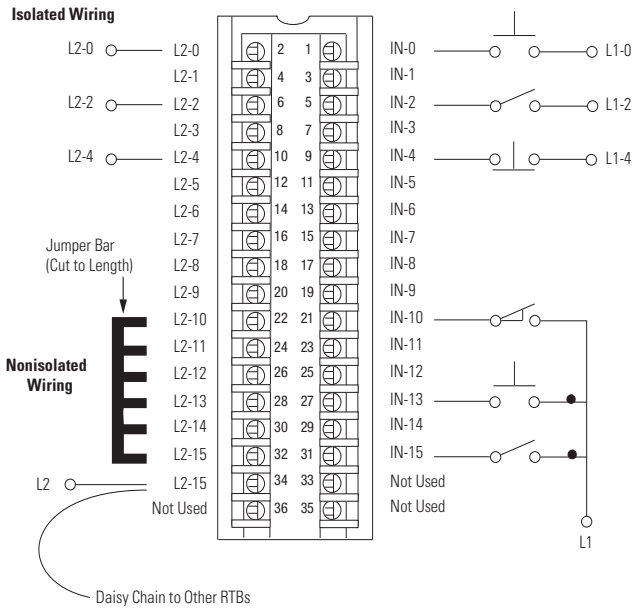

### Technical Specifications - 1756-IM16I, 1756-IM16IK

Attribute	1756-IM16I, 1756-IM16IK
Inputs	16 individually isolated
Voltage category	240V AC 50/60 Hz
Operating voltage range	159...265V AC, 47...63 Hz <sup>(2)</sup>
Input voltage, nom	240V AC 50/60 Hz
Input delay time (screw to backplane) Off to On	Hardware delay: 10 ms max + filter time User-selectable filter time: 1 ms or 2 ms
Onto Off	Hardware delay: 8 ms max + filter time User-selectable filter time: 9 ms or 18 ms
Current draw @ 5.1V	100 mA
Current draw @ 24V	3 mA
Total backplane power	0.58 W
Power dissipation, max	5.8 W @ 60 °C (140 °F)
Thermal dissipation	19.78 BTU/hr
Off-state voltage, max	40V

**Technical Specifications - 1756-IM16I, 1756-IM16IK**

Attribute	1756-IM16I, 1756-IM16IK
Off-state current, max	2.5 mA
On-state current, min	5 mA @ 159V AC, 60 Hz
On-state current, max	13 mA @ 265V AC, 60 Hz
On-state voltage	159...265V AC, 47...63Hz @ 30 °C (86 °F) all channels ON 159...265V AC, 47...63Hz @ 40 °C (104 °F) 8 points ON 159...253V AC, 47...63Hz @ 45 °C (113 °F) all channels ON 159...242V AC, 47...63Hz @ 60 °C (140 °F) all channels ON
Inrush current, max	250 mA
Input impedance, max	20.38 k $\Omega$ @ 265V AC, 60 Hz
Cyclic update time	200 $\mu$ s...750 ms
Change of state	Software configurable
Time stamp of inputs	$\pm$ 200 $\mu$ s
Isolation voltage	250V (continuous), basic insulation type, inputs-to-backplane, and input-to-input
Module keying	Electronic, software configurable
Removable terminal block housing	1756-TBCH 1756-TBS6H
RTB keying	User-defined mechanical
Slot width	1
Wire category <sup>(1)</sup>	1 - on signal ports 1 - on power ports
Enclosure type	None (open-style)
North American temperature code	T4

(1) Use this conductor category information for planning conductor routing as described in the system-level installation manual. See the Industrial Automation Wiring and Grounding Guidelines, publication [1770-4.1](#).

(2) UL certification for 240V 50/60 Hz nominal. Rockwell Automation specified to the following:

- 159...265V AC, 47...63Hz @ 30 °C (86 °F) all channels on
- 159...265V AC, 47...63Hz @ 40 °C (104 °F) 8 points on
- 159...253V AC, 47...63Hz @ 45 °C (113 °F) all channels on
- 159...242V AC, 47...63Hz @ 60 °C (140 °F) all channels on.

**Environmental Specifications - 1756-IM16I, 1756-IM16IK**

Attribute	1756-IM16I, 1756-IM16IK
Temperature, operating IEC 60068-2-1 (Test Ad, Operating Cold), IEC 60068-2-2 (Test Bd, Operating Dry Heat), IEC 60068-2-14 (Test Nb, Operating Thermal Shock)	0...60 °C (32...140 °F)
Temperature, surrounding air, max	60 °C (140 °F)
Temperature, nonoperating IEC 60068-2-1 (Test Ab, Unpackaged Nonoperating Cold), IEC 60068-2-2 (Test Bb, Unpackaged Nonoperating Dry Heat), IEC 60068-2-14 (Test N/A, Unpackaged Nonoperating Thermal Shock)	-40...+85 °C (-40...+185 °F)
Relative humidity IEC 60068-2-30 (Test dB, Unpackaged Damp Heat)	5...95% noncondensing
Vibration IEC 60068-2-6 (Test Fc, Operating)	2 g @ 10...500 Hz

**Environmental Specifications - 1756-IM16I, 1756-IM16IK**

Attribute	1756-IM16I, 1756-IM16IK
Shock, operating IEC 60068-2-27 (Test Ea, Unpackaged Shock)	30 g
Shock, nonoperating IEC 60068-2-27 (Test Ea, Unpackaged Shock)	50 g
Emissions	IEC 61000-6-4
ESD immunity IEC 61000-4-2	6 kV contact discharges 8 kV air discharges
Radiated RF immunity IEC 61000-4-3	10V/m with 1 kHz sine-wave 80% AM from 30 MHz to 1000 MHz 10V/m with 200 Hz 50% Pulse 100% AM at 900 MHz
EFT/B immunity IEC 61000-4-4	±4 kV at 5 kHz on signal ports
Surge transient immunity IEC 61000-4-5	±1 kV line-line (DM) and ±2 kV line-earth (CM) on signal ports
Conducted RF immunity IEC 61000-4-6	10V rms with 1 kHz sine-wave 80% AM from 150 kHz . . . 80 MHz

**Certifications - 1756-IM16I, 1756-IM16IK**

Certification (when product is marked) <sup>(1)</sup>	1756-IM16I, 1756-IM16IK
UL	UL Listed Industrial Control Equipment. See UL File E65584.
CSA	CSA Certified Process Control Equipment. See CSA File LR54689C. CSA Certified Process Control Equipment for Class I, Division 2 Group A,B,C,D Hazardous Locations. See CSA File LR69960C.
CE	European Union 89/336/EEC EMC Directive, compliant with: <ul style="list-style-type: none"> <li>• EN 61131-2; Programmable Controllers (Clause 8, Zone A &amp; B)</li> <li>• EN 61326-1; Meas./Control/Lab., Industrial Requirements</li> <li>• EN 61000-6-2; Industrial Immunity</li> <li>• EN 61000-6-4; Industrial Emissions</li> </ul> European Union 2014/35/EU LVD Directive, compliant with: <ul style="list-style-type: none"> <li>• EN 61131-2; Programmable Controllers (Clause 11)</li> </ul>
RCM	Australian Radiocommunications Act, compliant with: EN 61000-6-4; Industrial Emissions
FM	FM Approved Equipment for use in Class I Division 2 Group A,B,C,D Hazardous Locations
KC	Korean Registration of Broadcasting and Communications Equipment, compliant with: Article 58-2 of Radio Waves Act, Clause 3
EAC	Russian Customs Union TR CU 020/2011 EMC Technical Regulation Russian Customs Union TR CU 004/2011 LV Technical Regulation

(1) See the Product Certification link at [rok.auto/certifications](http://rok.auto/certifications) for Declarations of Conformity, Certificates, and other certification details.

## 1756-IN16

### ControlLogix AC (10...30V) input module

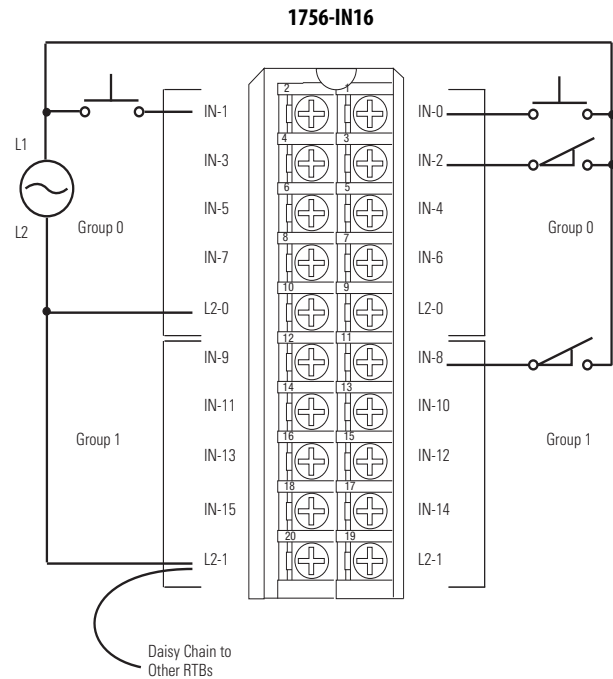
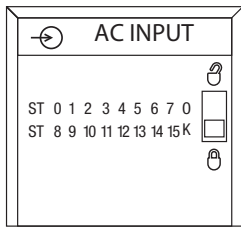
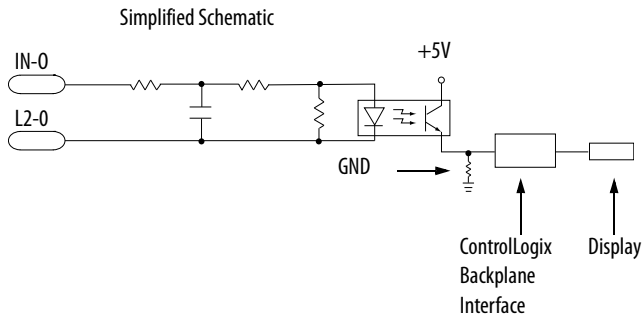

### Technical Specifications - 1756-IN16

Attribute	1756-IN16
Inputs	16 (8 points/group)
Voltage category	24V AC 50/60 Hz
Operating voltage range	10...30V AC, 47...63 Hz
Input voltage, nom	24V AC 50/60 Hz
Voltage and current ratings	Backplane: 5.1V DC, 135 mA 24V DC, 2 mA Inputs: 10...30V AC, 50/60Hz 25 mA max
Input delay time (screw to backplane)	
Off to On	Hardware delay: 10 ms max + filter time User-selectable filter time: 0 ms, 1 ms, or 2 ms
On to Off	Hardware delay: 10 ms max + filter time User-selectable filter time: 9 ms or 18 ms
Current draw @ 5.1V	135 mA
Current draw @ 24V	2 mA
Total backplane power	0.56 W
Power dissipation, max	5.1 W @ 60 °C (140 °F)
Thermal dissipation	17.39 BTU/hr
Off-state voltage, max	5V

**Technical Specifications - 1756-IN16 (continued)**

Attribute	1756-IN16
Off-state current, max	2.75 mA
On-state current, min	5 mA @ 10V AC, 60 Hz
On-state current, max	1.2 mA @ 30V AC, 60 Hz
Inrush current, max	250 mA
Input impedance, max	2.5 k $\Omega$ @ 30V AC, 60 Hz
Cyclic update time	200 $\mu$ s...750 ms
Change of state	Software configurable
Time stamp of inputs	$\pm$ 200 $\mu$ s
Isolation voltage	250V (continuous), basic insulation type, inputs-to-backplane, and input group-to-group No isolation between individual group inputs
Module keying	Electronic, software configurable
Removable terminal block housing	1756-TBNH 1756-TBSH
RTB keying	User-defined mechanical
Wire Size	1756-TBNH Single wire connection: 0.33...2.1 mm <sup>2</sup> (22...14 AWG) solid or stranded shielded copper wire rated at 105 °C (221 °F), or greater, 1.2 mm (3/64 in.) insulation max. Double wire connection: 0.33...1.3 mm <sup>2</sup> (22...16 AWG) solid or stranded copper wire rated at 105 °C (221 °F), or greater, 1.2 mm (3/64 in.) insulation max.  1756-TBSH Single wire connection: 0.33...2.1 mm <sup>2</sup> (22...14 AWG) solid or stranded shielded copper wire rated at 105 °C (221 °F), or greater, 1.2 mm (3/64 in.) insulation max.
Terminal block torque specs	1756-TBNH 1.36 N·m (12 lb-in)
Slot width	1
Wire category <sup>(1)</sup>	1 - on signal ports
Enclosure type	None (open-style)
North American temperature code	T3C
ATEX	T3
IECEx temperature code	T3

(1) Use this conductor category information for planning conductor routing as described in the system-level installation manual. See the Industrial Automation Wiring and Grounding Guidelines, publication [1770-4.1](#).

**Environmental Specifications - 1756-IN16**

Attribute	1756-IN16
Temperature, operating IEC 60068-2-1 (Test Ad, Operating Cold), IEC 60068-2-2 (Test Bd, Operating Dry Heat), IEC 60068-2-14 (Test Nb, Operating Thermal Shock)	0 °C < Ta < 60 °C (32 °F < Ta < 140 °F)
Temperature, surrounding air, max	60 °C (140 °F)
Temperature, nonoperating IEC 60068-2-1 (Test Ab, Unpackaged Nonoperating Cold), IEC 60068-2-2 (Test Bb, Unpackaged Nonoperating Dry Heat), IEC 60068-2-14 (Test N/A, Unpackaged Nonoperating Thermal Shock)	-40...+85 °C (-40...+185 °F)
Relative humidity IEC 60068-2-30 (Test dB, Unpackaged Damp Heat)	5...95% noncondensing

**Environmental Specifications - 1756-IN16 (continued)**

Attribute	1756-IN16
Vibration IEC 60068-2-6 (Test Fc, Operating)	2 g @ 10...500 Hz
Shock, operating IEC 60068-2-27 (Test Ea, Unpackaged Shock)	30 g
Shock, nonoperating IEC 60068-2-27 (Test Ea, Unpackaged Shock)	30 g
Emissions	IEC 61000-6-4
ESD immunity IEC 61000-4-2	6 kV contact discharges 8 kV air discharges
Radiated RF immunity IEC 61000-4-3	10V/m with 1 kHz sine-wave 80% AM from 80...2000 MHz 10V/m with 200 Hz 50% Pulse 100% AM @ 900 MHz 10V/m with 200 Hz 50% Pulse 100% AM @ 1890 MHz 3V/m with 1 kHz sine-wave 80% AM from 2000...2700 MHz
EFT/B immunity IEC 61000-4-4	±4 kV at 5 kHz on signal ports
Conducted RF immunity IEC 61000-4-6	10V rms with 1 kHz sine-wave 80% AM from 150 kHz...80 MHz

**Certifications - 1756-IN16**

Certification (when product is marked) <sup>(1)</sup>	1756-IN16
UL	UL Listed Industrial Control Equipment. See UL File E65584.
CSA	CSA Certified Process Control Equipment. See CSA File LR54689C. CSA Certified Process Control Equipment for Class I, Division 2 Group A,B,C,D Hazardous Locations. See CSA File LR69960C.
CE	European Union 2014/30/EU EMC Directive, compliant with: <ul style="list-style-type: none"> <li>EN 61326-1; Meas./Control/Lab., Industrial Requirements</li> <li>EN 61000-6-2; Industrial Immunity</li> <li>EN 61000-6-4; Industrial Emissions</li> <li>EN 61131-2; Programmable Controllers (Clause 8, Zone A &amp; B)</li> </ul> European Union 2014/35/EU LVD, compliant with: EN 61131-2; Programmable Controllers (Clause 11)
RCM	Australian Radiocommunications Act, compliant with: EN 61000-6-4; Industrial Emissions
Ex	European Union 2014/34/EU ATEX Directive, compliant with: <ul style="list-style-type: none"> <li>EN 60079-0; General Requirements</li> <li>EN 60079-15; Potentially Explosive Atmospheres, Protection "n"</li> <li>II 3 G Ex nA IIC T3 Gc</li> <li>DEMKO16ATEX1792X</li> </ul>
IECEX	IECEX System, compliant with: <ul style="list-style-type: none"> <li>IEC 60079-0; General Requirements</li> <li>IEC 60079-15; Potentially Explosive Atmospheres, Protection "n"</li> <li>II 3 G Ex nA IIC T3 Gc</li> <li>IECEXUL16.0151X</li> </ul>
KC	Korean Registration of Broadcasting and Communications Equipment, compliant with: Article 58-2 of Radio Waves Act, Clause 3
EAC	Russian Customs Union TR CU 020/2011 EMC Technical Regulation Russian Customs Union TR CU 004/2011 LV Technical Regulation
FM	FM Approved Equipment for use in Class I Division 2 Group A,B,C,D Hazardous Locations

(1) See the Product Certification link at [rockwellautomation.com/certifications](http://rockwellautomation.com/certifications) for Declarations of Conformity, Certificates, and other certification details.



## 1756-IR6I

ControlLogix temperature sensing analog input module

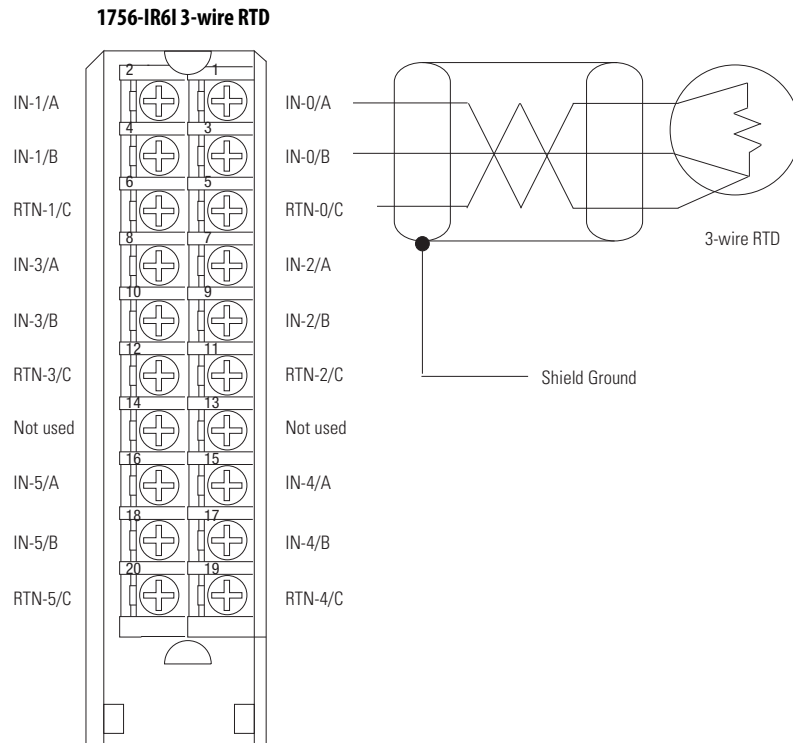

**IMPORTANT:** For 2-wire resistor applications including calibration, make sure IN-x/B and RTN-x/C are shorted together as shown.

**1756-IR6I 4-wire RTD**

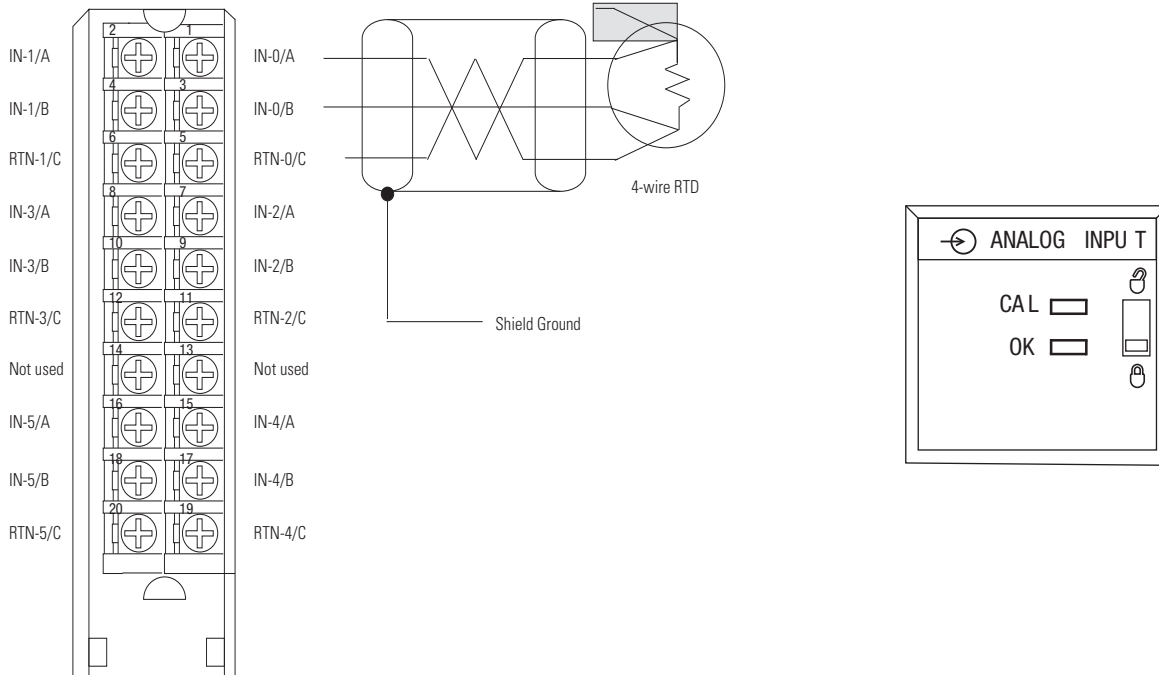

**Signal and User Counts - 1756-IR6I**

Range	Low Signal and User Counts	High Signal and User Counts
1...487 Ω	0.859068653 Ω -32768 counts	507.862 Ω 32767 counts
2...1000 Ω	2 Ω -32768 counts	1016.502 Ω 32767 counts
4...2000 Ω	4 Ω -32768 counts	2033.780 Ω 32767 counts
8...4020 Ω	8 Ω -32768 counts	4068.392 Ω 32767 counts

**Technical Specifications - 1756-IR6I**

Attribute	1756-IR6I
Inputs	6 individually isolated RTD
Input range	1...487 Ω 2...1000 Ω 4...2000 Ω 8...4000 Ω
Resolution	16 bits 1...487 Ω: 7.7 mΩ/bit 2...1000 Ω: 15 mΩ/bit 4...2000 Ω: 30 mΩ/bit 8...4020 Ω: 60 mΩ/bit

**Technical Specifications - 1756-IR6I (continued)**

Attribute	1756-IR6I
Sensors supported	100, 200, 500, 1000 $\Omega$ Platinum, $\alpha=385$ 100, 200, 500, 1000 $\Omega$ Platinum, $\alpha=3916$ 120 $\Omega$ Nickel, $\alpha=672$ 100, 120, 200, 500 $\Omega$ Nickel, $\alpha=618$ 10 $\Omega$ Copper
Current draw @ 5.1V	250 mA
Current draw @ 24V	125 mA
Total backplane power	4.25 W
Power dissipation, max	4.3 W
Thermal dissipation	14.66 BTU/hr
Open circuit detection time	Negative full scale reading within 5 s with any combination of lost wires, except input terminal A alone. If input terminal A is lost by itself, the module reads a positive full scale reading within 5 s
Overvoltage protection, max	24V AC/DC
Normal mode noise rejection	60 dB at 60 Hz <sup>(2)</sup>
Common mode noise rejection	120 dB @ 60 Hz 100 dB @ 50 Hz
Channel bandwidth	15 Hz <sup>(2)</sup>
Settling time	<80 ms to 5% of full scale <sup>(2)</sup>
Calibrated accuracy @ 25 °C	Better than 0.1% of range
Calibration interval	6 months
Offset drift	10 M $\Omega$ /°C
Gain drift with temperature, nom	50 ppm/°C
Gain drift with temperature, max	90 ppm/°C
Module error	0.54% of range
Module scan time	25 ms min floating point (ohms) 50 ms min floating point (temperature) 10 ms min integer (ohms) <sup>(2)</sup>
Data format	Integer mode (left justified, 2 s complement) IEEE 32-bit floating point
Module conversion method	Sigma-Delta
Isolation voltage	250V (continuous), basic insulation type, input channels-to-backplane, and input channel-to-channel
Module keying	Electronic, software configurable
Removable terminal block	1756-TBNH 1756-TBSH
RTB keying	User-defined mechanical
Slot width	1
Wire category <sup>(1)</sup>	2
Enclosure type	None (open-style)
North American temperature code	T4A
IEC temperature code	T4

(1) Use this conductor category information for planning conductor routing as described in the system-level installation manual. See the Industrial Automation Wiring and Grounding Guidelines, publication [1770-4.1](#).

(2) Notch filter dependent.

**Environmental Specifications - 1756-IR6I**

<b>Attribute</b>	<b>1756-IR6I</b>
Temperature, operating IEC 60068-2-1 (Test Ad, Operating Cold), IEC 60068-2-2 (Test Bd, Operating Dry Heat), IEC 60068-2-14 (Test Nb, Operating Thermal Shock)	0...60 °C (32...140 °F)
Temperature, surrounding air, max	60 °C (140 °F)
Temperature, nonoperating IEC 60068-2-1 (Test Ab, Unpackaged Nonoperating Cold), IEC 60068-2-2 (Test Bb, Unpackaged Nonoperating Dry Heat), IEC 60068-2-14 (Test N/A, Unpackaged Nonoperating Thermal Shock)	-40...+85 °C (-40...+185 °F)
Relative humidity IEC 60068-2-30 (Test dB, Unpackaged Damp Heat)	5...95% noncondensing
Vibration IEC 60068-2-6 (Test Fc, Operating)	2 g @ 10...500 Hz
Shock, operating IEC 60068-2-27 (Test Ea, Unpackaged Shock)	30 g
Shock, nonoperating IEC 60068-2-27 (Test Ea, Unpackaged Shock)	50 g
Emissions	IEC 61000-6-4
ESD immunity IEC 61000-4-2	6 kV contact discharges 8 kV air discharges
Radiated RF immunity IEC 61000-4-3	10V/m with 1 kHz sine-wave 80% AM from 80...2000 MHz 10V/m with 200 Hz 50% Pulse 100% AM @ 900 MHz 10V/m with 200 Hz 50% Pulse 100% AM @ 1890 MHz 3V/m with 1 kHz sine-wave 80% AM from 2000...2700 MHz
EFT/B immunity IEC 61000-4-4	±2 kV at 5 kHz on shielded signal ports
Surge transient immunity IEC 61000-4-5	±2 kV line-earth (CM) on shielded signal ports
Conducted RF immunity IEC 61000-4-6	10V rms with 1 kHz sine-wave 80% AM from 150 kHz...80 MHz on shielded signal ports

**Certifications - 1756-IR6I**

<b>Certification (when product is marked)<sup>(1)</sup></b>	<b>1756-IR6I</b>
UL	UL Listed Industrial Control Equipment. See UL File E65584.
CSA	CSA Certified Process Control Equipment. See CSA File LR54689C. CSA Certified Process Control Equipment for Class I, Division 2 Group A,B,C,D Hazardous Locations. See CSA File LR69960C.
CE	European Union 2014/30/EU EMC Directive, compliant with: <ul style="list-style-type: none"> <li>• EN 61326-1; Meas./Control/Lab., Industrial Requirements</li> <li>• EN 61000-6-2; Industrial Immunity</li> <li>• EN 61000-6-4; Industrial Emissions</li> <li>• EN 61131-2; Programmable Controllers (Clause 8, Zone A &amp; B)</li> </ul> European Union 2014/35/EU LVD, compliant with: EN 61131-2; Programmable Controllers (Clause 11)
RCM	Australian Radiocommunications Act, compliant with: EN 61000-6-4; Industrial Emissions
Ex	European Union 2014/34/EU ATEX Directive, compliant with: <ul style="list-style-type: none"> <li>• EN 60079-15; Potentially Explosive Atmospheres, Protection "n"</li> <li>• EN 60079-0; General Requirements II 3 G Ex nA IIC T4 X Gc</li> </ul>
FM	FM Approved Equipment for use in Class I Division 2 Group A,B,C,D Hazardous Locations
KC	Korean Registration of Broadcasting and Communications Equipment, compliant with: Article 58-2 of Radio Waves Act, Clause 3
EAC	Russian Customs Union TR CU 020/2011 EMC Technical Regulation Russian Customs Union TR CU 004/2011 LV Technical Regulation

(1) See the Product Certification link at [rok.auto/certifications](http://rok.auto/certifications) for Declarations of Conformity, Certificates, and other certification details.

## 1756-IRT8I, 1756-IRT8IK

ControlLogix isolated RTD/Thermocouple analog input module.

### 1756-IRT8I, 1756-IRT8IK Module Wiring Diagram - 3-wire RTD Input

**IMPORTANT:** Remember the following:

- If separate power sources are used, do not exceed the specific isolation voltage as listed in the specifications.
- Terminals 1, 2, 35, and 36 are not used in RTD applications.
- For 2-wire resistor applications including calibration, make sure IN\_x(-)/B and IN\_x/RTD C are shorted together.

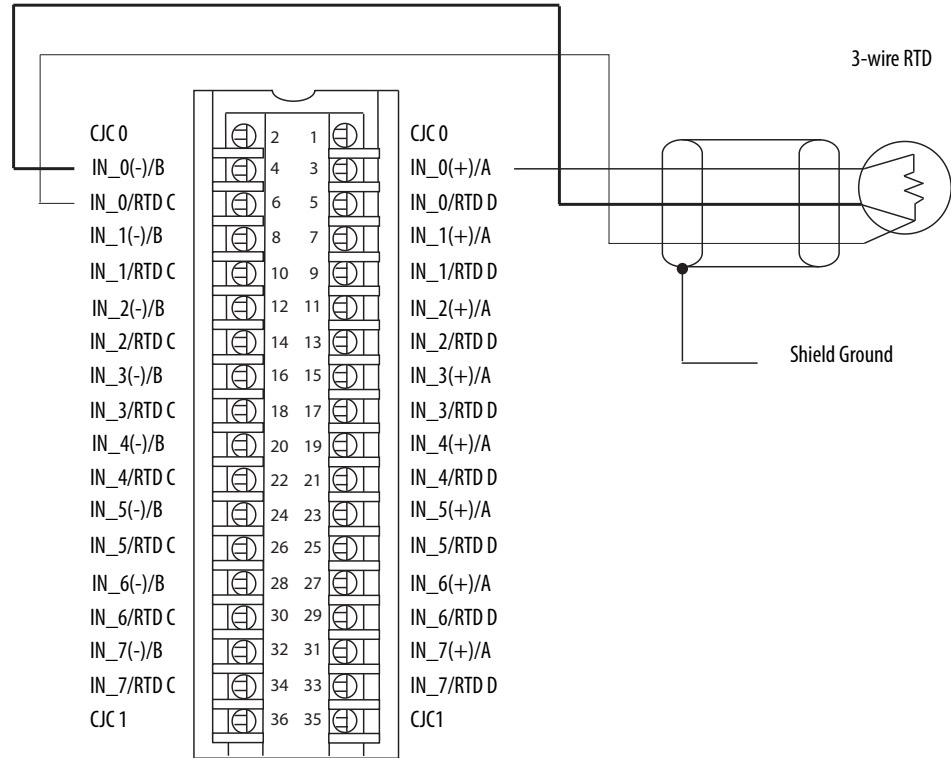

### 1756-IRT8I, 1756-IRT8IK Module Wiring Diagram - 4-wire RTD Input

**IMPORTANT:** Remember the following:

- If separate power sources are used, do not exceed the specific isolation voltage as listed in the specifications.
- Terminals 1, 2, 35, and 36 are not used in RTD applications.

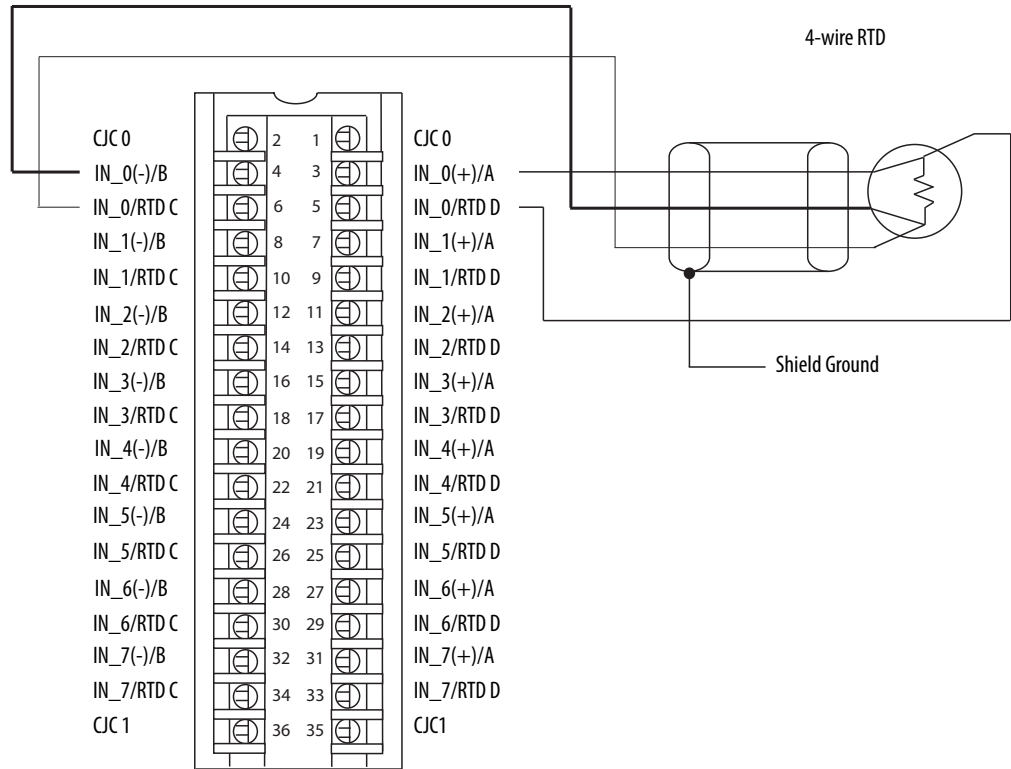

**1756-IRT8I, 1756-IRT8IK Module Wiring Diagram - Thermocouple Input**

**IMPORTANT:** Remember the following:

- Connect the white end of the CJC sensor to the even-numbered terminal. Connect the orange end of the CJC sensor to the odd-numbered terminals.

For CJC 0:

- White end - Connected to terminal number 2
- Orange end - Connected to terminal number 1

For CJC 1:

- White end - Connected to terminal number 36
- Orange end - Connected to terminal number 35

- CJC sensors do not come with the module. You must order the sensors, product catalog number 1756-CJC, separately.
- If separate power sources are used, do not exceed the specific isolation voltage as listed in the specifications.

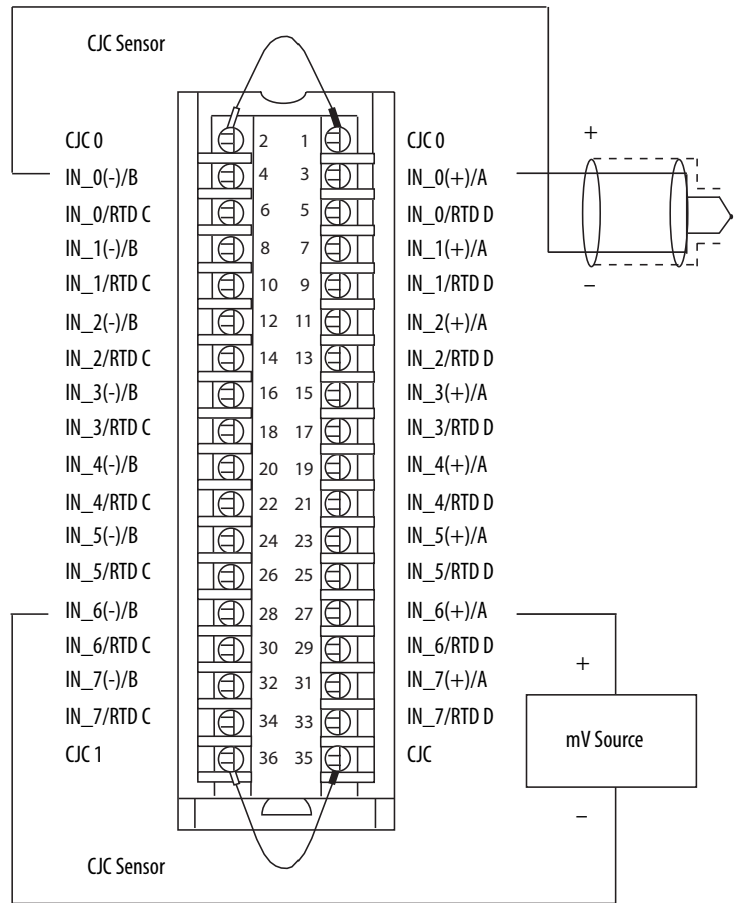
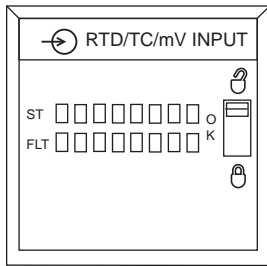

**Technical Specifications - 1756-IRT8I, 1756-IRT8IK**

Attribute	1756-IRT8I, 1756-IRT8IK
Inputs	Eight isolated channels - Any combination of RTD or Thermocouple mode Two CJC sensors for Thermocouple use. The CJC sensors, product catalog number 1756-CJC, do not come with the module. You must order the sensors separately.
Input range	1...500 Ω 2...1000 Ω 4...2000 Ω 8...4000 Ω -100...100 mV
Resolution	24 bits 0...510 Ω: 0.06 mΩ/count 0...1020 Ω: 0.12 mΩ/count 0...2040 Ω: 0.25 mΩ/count 0...4080 Ω: 0.50 mΩ/count -101...101 mV: 0.01 μV/count
RTD sensors supported	100, 200, 500, 1000 Ω Platinum, alpha=385 100, 200, 500, 1000 Ω Platinum, alpha=3916 120 Ω Nickel, alpha=672 100, 120, 200, 500 Ω Nickel, alpha=618 10 Ω Copper, alpha=427

## 1756-CMS1B1, 1756-CMS1C1

ControlLogix Compute modules are chassis-based modules that let you communicate directly with a ControlLogix 5570 or ControlLogix 5580 controller via the system backplane and over a network. The Compute modules offer an embedded Microsoft® Windows 10 or Linux operating system within which you can create custom applications while utilizing an application programming interface (API).

### Technical Specifications - 1756-CMS1B1, 1756-CMS1C1

Attribute	1756-CMS1B1	1756-CMS1C1
Solid state drive (SSD) capacity	32 GB	
Embedded operating system	Windows 10 IoT Enterprise LTSB 64 bit	Linux 32 bit (Debian 8.9)
Onboard memory	4 GB	
Voltage and current ratings	5.1V DC @ 1.40 A	
Power consumption	7 W	
Power dissipation, max	7 W	
Thermal dissipation	23.88 BTU/hr	
Replacement battery	Panasonic Type BR1225A coin type lithium battery - Commercially available	
Weight, approx	0.394 kg (0.868 lb)	
Slot width	1	
Module location	ControlLogix chassis, any slot	
Chassis	1756-A4, 1756-A7, 1756-A10, 1756-A13, 1756-A17 Series B, Series C	
Wire size	Ethernet connections Ethernet cabling and installation according to IEC 61918 and IEC 61784-5-2	
Wiring category <sup>(1)</sup>	3 - on USB port 2 - on Ethernet ports	
North American temperature code	T5	
Enclosure type rating	None (open-style)	

(1) Use this Conductor Category information for planning conductor routing. Refer to Industrial Automation Wiring and Grounding Guidelines, publication [1770-4.1](#).

### Environmental Specifications - 1756-CMS1B1, 1756-CMS1C1

Attribute	1756-CMS1B1, 1756-CMS1C1
Temperature, operating IEC 60068-2-1 (Test Ad, Operating Cold), IEC 60068-2-2 (Test Bd, Operating Dry Heat), IEC 60068-2-14 (Test Nb, Operating Thermal Shock)	Series C Chassis: -25 °C < Ta < +60 °C (-13 °F < Ta < +140 °F) Series B Chassis: -25 °C < Ta < +50 °C (-13 °F < Ta < +122 °F)
Temperature, surrounding air, max	Series C Chassis: 60 °C (140 °F) Series B Chassis: 50 °C (122 °F)
Temperature, nonoperating IEC 60068-2-1 (Test Ab, Unpackaged Nonoperating Cold), IEC 60068-2-2 (Test Bb, Unpackaged Nonoperating Dry Heat), IEC 60068-2-14 (Test Na, Unpackaged Nonoperating Thermal Shock)	-40...+85 °C (-40...+185 °F)
Relative humidity IEC 60068-2-30 (Test Db, Unpackaged Damp Heat)	5...95% noncondensing
Vibration IEC 60068-2-6 (Test Fc, Operating)	2 g @ 10...500 Hz
Shock, operating IEC 60068-2-27 (Test Ea, Unpackaged Shock)	30 g