

Environment and Enclosure



ATTENTION: This equipment is intended for use in overvoltage Category II applications (as defined in EN/IEC 60664-1), at altitudes up to 2000 m (6562 ft) without derating. This equipment is not intended for use in residential environments and may not provide adequate protection to radio communication services in such environments.

This equipment is supplied as enclosed equipment. It should not require additional system enclosure when used in locations consistent with the equipment Enclosure Type Ratings. Subsequent sections of this publication may contain more information regarding specific enclosure type ratings, beyond what this product provides, that are required to comply with certain product safety certifications.

In addition to this publication, see the following:

- Industrial Automation Wiring and Grounding Guidelines, publication [1770-4.1](#), for additional installation requirements.
- NEMA Standard 250 and EN/IEC 60529, as applicable, for explanations of the degrees of protection provided by enclosures.



ATTENTION: Read this document and the documents listed in the Additional Resources section about installation, configuration, and operation of this equipment before you install, configure, operate, or maintain this product. Users are required to familiarize themselves with installation and wiring instructions in addition to requirements of all applicable codes, laws, and standards.

Installation, adjustments, putting into service, use, assembly, disassembly, and maintenance are required to be carried out by suitably trained personnel in accordance with applicable code of practice. In case of malfunction or damage, no attempts at repair should be made. The module should be returned to the manufacturer for repair. Do not dismantle the module.

Prevent Electrostatic Discharge



ATTENTION: This equipment is sensitive to electrostatic discharge, which can cause internal damage and affect normal operation. Follow these guidelines when you handle this equipment:

- Touch a grounded object to discharge potential static.
- Wear an approved grounding wriststrap.
- Do not touch connectors or pins on component boards.
- Do not touch circuit components inside the equipment.
- Use a static-safe workstation, if available.
- Store the equipment in appropriate static-safe packaging when not in use.



ATTENTION:

- If this equipment is used in a manner not specified by the manufacturer, the protection provided by the equipment may be impaired.
- Read this document and the documents listed in the Additional Resources section about installation, configuration, and operation of this equipment before you install, configure, operate, or maintain this product. Users are required to familiarize themselves with installation and wiring instructions in addition to requirements of all applicable codes, laws, and standards.
- Installation, adjustments, putting into service, use, assembly, disassembly, and maintenance are required to be carried out by suitably trained personnel in accordance with applicable code of practice. In case of malfunction or damage, no attempts at repair should be made. The module should be returned to the manufacturer for repair. Do not dismantle the module.
- This equipment is certified for use only within the surrounding air temperature range of -20...+55 °C (-4...+131 °F). The equipment must not be used outside of this range.
- Use only a soft dry anti-static cloth to wipe down equipment. Do not use any cleaning agents.



WARNING:

- Secure any external connections that mate to this equipment by using screws, sliding latches, threaded connectors, or other means provided with this product.
- Do not disconnect equipment unless power has been removed or the area is known to be nonhazardous.
- The secondary of a current transformer shall not be open-circuited when applied in Class I, Zone 2 environments.

Before You Begin

The 1732E-8X8M12DR EtherNet/IP™ ArmorBlock® I/O module is a 24V DC module that communicates via EtherNet/IP. The sealed IP65, IP67, and IP69K housing of these modules requires no enclosure. I/O connectors are sealed M12 style.

EtherNet/IP networks use advanced network technology, for example, producer/consumer communication, to increase network functionality and throughput.

See [Figure 1 on page 4](#) to familiarize yourself with major parts of the module.

Figure 1 - Module Identification

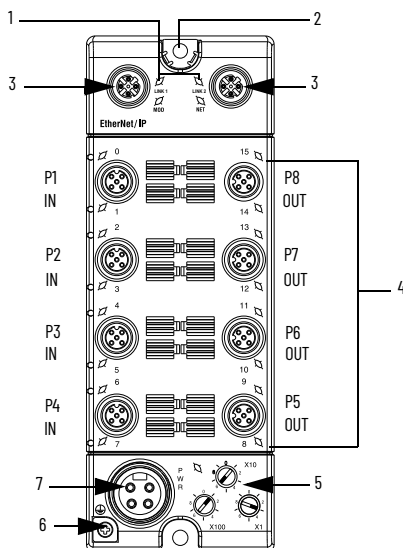

Component Description

	Description		Description
1	Status Indicators	5	Node address switches
2	Functional Earth ⁽¹⁾	6	Protective Earth ⁽²⁾
3	EtherNet/IP D-Code M12 connector	7	Auxiliary power
4	M12 I/O connectors		

(1) Functional Earth grounds the I/O block's EtherNet/IP communication circuitry which is designed to mitigate the effect of noise on the network. See [EtherNet/IP Connector on page 6](#).
 (2) Protective Earth is provided for the grounding of field devices and is internally connected to each Pin 5 of the M12 I/O connectors. See [I/O Connectors on page 6](#).

Catalog Number Explanation

Catalog Number	Description	Network Connector	Auxiliary Power
1732E-8X8M12DR	Diagnostic 8-Input/8-Output 24V DC Digital I/O Dual-Port EtherNet Module	Dual D-code M12	Single 4-pin mini

Install the Module

To install the module:

- Set the network address
- Mount the module
- Connect the I/O, Network and Auxiliary cables to the module.

Set the Network Address

The I/O block ships with the rotary switches set to 999 and DHCP enabled.

To change the network address, you can do one of the following:

- Adjust the switch on the front of the module.
- Use a Dynamic Host Configuration Protocol (DHCP) server, such as Rockwell Automation® BootP/DHCP.
- Retrieve the IP address from nonvolatile memory.

The I/O block reads the switches first to determine if the switches are set to a valid number. To set the network address:

1. Rotate the three (3) switches on the front of the module using a small blade screwdriver.
2. Line up the small notch on the switch with the number setting you wish to use.
3. Valid settings range from 001...254.
4. Cycle power.

Set Network Address

Example shows default node address set at 163.

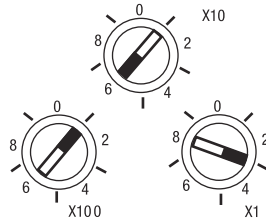

When the switches are set to a valid number, the I/O block's IP address is 192.168.1.xxx (where xxx represents the number set on the switches). The I/O block's subnet mask is 255.255.255.0 and the gateway address is set to 0.0.0.0. When the I/O block uses the network address set on the switches, the I/O block does not have a host name assigned to it or use any Domain Name Server.

If the switches are set to an invalid number (for example, 000 or a value greater than 254 excluding 888), the I/O block checks to see if DHCP is enabled. If DHCP is enabled, the I/O block asks for an address from a DHCP server. The DHCP server also assigns other Transport Control Protocol (TCP) parameters.

If DHCP is not enabled, the I/O block uses the IP address (along with other TCP configurable parameters) stored in nonvolatile memory.

Mount the Module

Two sets of mounting holes are used to mount the module directly to a panel or machine. Mounting holes accommodate #8 (M4) pan head screws. The torque specification is 1.13 N•m (10 lb•in).

Product Dimensions

See [Figure 2](#) for the mounting dimensions illustration to help you mount the module.

Figure 2 - Module Dimensions

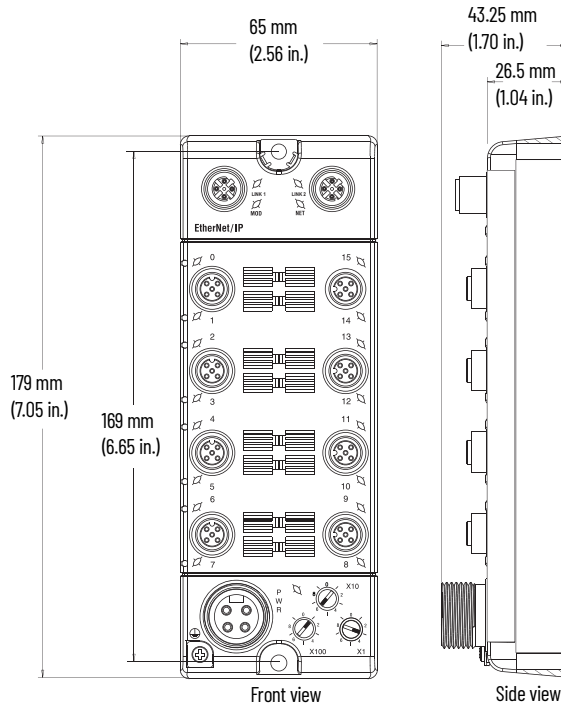

Mount the Module in High Vibration Areas

If you mount the module in an area that is subject to shock or vibration, we recommend you use a flat and a lock washer to mount the module. Mount the flat and the lock washer as shown in the mounting illustration. Torque the mounting screws to 1.13 N•m (10 in•lb).

Figure 3 - High Vibration Area Mounting

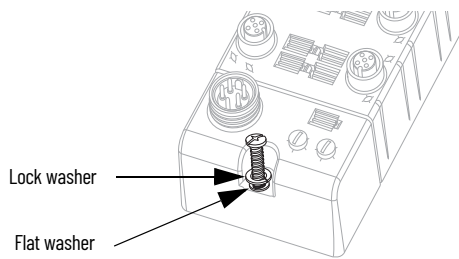

Connect the I/O, Network and Auxiliary Cables to the Module

The ArmorBlock EtherNet/IP family has 5-pin micro-style connectors. We provide caps to cover the unused connectors on your module. Connect the quick-disconnect cord sets you selected for your module to the appropriate ports.

I/O Connectors

See the pinout diagrams for the I/O connectors.

Figure 4 - Micro-style 5-pin input Female Connector

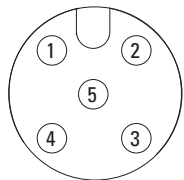

(View into connector)
 Pin 1 Sensor source voltage
 Pin 2 Input B
 Pin 3 Return
 Pin 4 Input A
 Pin 5 PE

Figure 5 - Micro-style 5-pin Output Female Connector

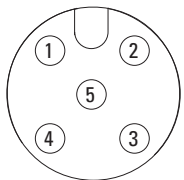

(View into connector)
 Pin 1 Not used
 Pin 2 Output B
 Pin 3 Return
 Pin 4 Output A
 Pin 5 PE

EtherNet/IP Connector

Figure 6 - D-Code Micro Network Female Connector

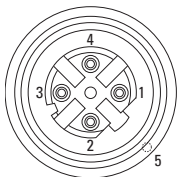

(View into connector)
 Pin 1 M12_Tx+
 Pin 2 M12_Rx+
 Pin 3 M12_Tx-
 Pin 4 M12_Rx-
 Pin 5 Connector shell shield FE



ATTENTION: Make sure all connectors and caps are securely tightened to properly seal the connections against leaks and maintain IP enclosure requirements.

IMPORTANT

Use the 1585D-M4DC-H: Polyamide small body unshielded or the 1585D-M4DC-SH: Zinc die-cast large body shielded mating connectors for the D-Code M12 female network connector. Use two twisted pair CAT5E UTP or STP cables.

D-Code M12 Pin	Wire Color	Signal	8-way Modular RJ45 Pin
1	White-Orange	TX+	1
2	White-Green	RX+	3
3	Orange	TX-	2
4	Green	RX-	6

Auxiliary Power Connector

Attach the mini-style 4-pin connector to the mini-style 4-pin receptacle as shown in [Figure 7](#).

Figure 7 - Mini-style 4-pin Input Male Receptacle

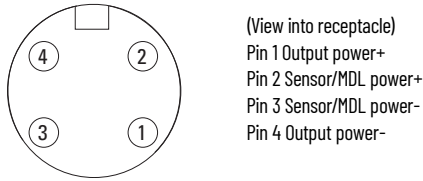

Auxiliary Power is based on a 4-pin connector system and is used to provide 24V DC power to I/O modules and other devices. Running separate power to these devices is most typically used for I/O devices with output connections to prevent power supply interruption due to switching of outputs. However, some devices require separate auxiliary power to power them regardless of the presence of outputs.

Depending on the devices used, it may be possible to provide power through only one pair of the four available pins, and in this case the other available pair may be used for single channel E-stop through the use of special E-stop drop or power T-ports and shorting plugs. Allen-Bradley® E-stop T-ports and shorting plugs are red in color for easy identification.



ATTENTION: To comply with the CE Low Voltage Directive (LVD), this equipment and all connected I/O must be powered from a source compliant with the following:
 Safety Extra Low Voltage (SELV) or Protected Extra Low Voltage (PELV).



ATTENTION: To comply with UL restrictions, this equipment must be powered from a source compliant with the following: Limited Voltage/Current.

Configure the Module

See [Figure 8](#) for configuration operations.

Figure 8 - Configure Operations

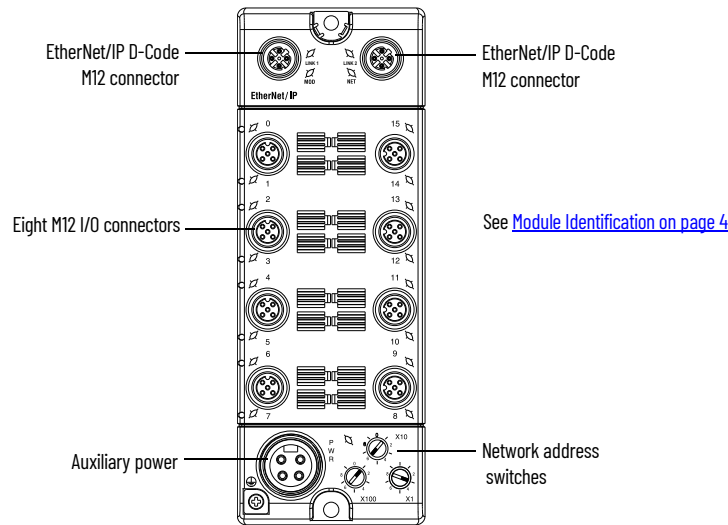

See Essential Components Selection Guide, publication [EC-CA100](#), for Rockwell Automation cable and cord set offerings or use the configuration tools available at rok.auto/systemtools.

Interpret Status Indicators

This module has the following indicators:

- Network, Module, and Link status indicators for EtherNet/IP
- Auxiliary Power indicator
- Individual I/O status indicators for inputs and outputs

Figure 9 - Status Indicators

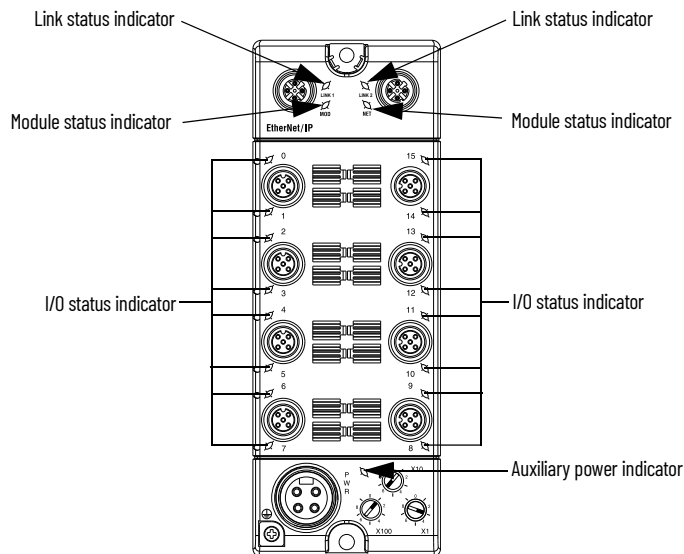

Indicator Status for Modules

Indicator	Status	Description
Module status	Off	No power applied to device.
	Flashing red/green	The module is performing POST (Power-On Self Test), which completes within 30 s.
	Green	Device operating normally.
	Flashing red	Recoverable fault.
	Red	Unrecoverable fault - may require device replacement.
Network status	Off	The device is not initialized or the module does not have an IP address.
	Flashing green	The device has no CIP™ connections. The device has an IP address, but no CIP connections are established.
	Green	The device is online, has an IP address, and CIP connections are established.
	Flashing red	One or more connections have timed out.
	Red	The module has detected that its IP address is already in use.
	Flashing red/green	The module is performing a powerup self-test.
Network link status	Off	No link established.
	Green	Link established on indicated port at 100 Mbps.
	Flashing green	Link activity present on indicated port at 100 Mbps.
	Yellow	Link established on indicated port at 10 Mbps.
	Flashing yellow	Link activity present on indicated port at 10 Mbps.
Auxiliary status	Off	No auxiliary power to device or input not valid.
	Green	Auxiliary power applied to device.
Digital output status	Off	Output not energized.
	Yellow	Output energized.
	Red	Output shorted.
	Flashing red	Output open load.

Indicator Status for Modules (Continued)

Indicator	Status	Description
Digital input status	Off	No valid input.
	Yellow	Valid input.
	Red	Sensor source voltage shorted.
	Flashing red	Sensor source open wire.

Specifications**Input Specifications**

Attribute	Value
Number of inputs	8
Input type	Sink, 24V DC
Voltage, off-state input, max	5V DC
Voltage, on-state input, min	12V DC
Voltage, on-state input, nom	24V DC
Voltage, on-state input, max	30V DC
Current, off-state input, max	1.5 mA @ 5V DC
Current, on-state input, max	5 mA @ 30V DC
Voltage, sensor source, min	10V DC
Voltage, sensor source, max	30V DC
Input delay time ON to OFF OFF to ON	0...16000 μ s
Isolation voltage	50V (continuous), Basic Insulation Type, Inputs and Sensor Power to Network. No isolation between individual Inputs or between Network channels. Type tested at 707V DC for 60 s.

Output Specifications

Attribute	Value
Number of outputs	8
Output type	Source, 24V DC
Voltage drop, on-state output, max	0.5V DC
Voltage off-peak blocking, min	30V DC
Voltage, on-state output, min	12V DC
Voltage, on-state output, nom	24V DC
Voltage, on-state output, max	30V DC
Current, on-state output, max	0.5 A
Current per module, max	4.0 A
Leakage current, off-state output, max	500 μ A
Surge current per output, min	1.2 A for 10 ms, repeatable every 2 s
Pilot duty rating	DC-14
Isolation voltage	50V (continuous), Basic Insulation Type, Outputs and Output Power to Network. No isolation between individual Outputs or between Outputs and Output power or between Network channels. Type tested at 707V DC for 60 s.

General Specifications

Attribute	Value
Voltage, auxiliary power, max	30V DC
Voltage, auxiliary power, min	12V DC
Current, Ethernet system power, max (pins 2, 3 sensor source/module power)	0.8 A
Current, auxiliary power, max per output module (pins 2, 3 sensor source/module power plus pins 1, 4 for output loads)	4 A
Current, sensor source, per input, max	50 mA
Current, sensor source, per connector, max	100 mA
Communication rate	EtherNet/IP 10/100 Mbps Full or half-duplex 100 meter per segment
Isolation voltage	50V (continuous), Basic Insulation Type, Inputs and Sensor Power to Network No isolation between individual Inputs or between Network channels Type tested at 707V DC for 60 s
Status indicators	Module status - red/green Network status - red/green Link status - green/yellow Auxiliary power - green I/O LED - yellow I/O LED - yellow/red
Dimensions (HxWxD), approx.	179 x 65 x 43.25 mm (7.05 x 2.56 x 1.70 in.)
Weight, approx.	340 g (11.99 oz.)
Wiring category ^{(1) (2)}	1 - on signal ports 1 - on power ports 1 - on communications port
Enclosure type rating	Meets IP65/66/67/69K (when marked), and Type 4X, 6P with receptacle dust caps or cable termination.
North American temp code	T5
ATEX temp code	T4
IECEX temp code	T4

(1) Use this conductor category information for planning conductor routing as described in Industrial Automation Wiring and Grounding Guidelines, publication [1770-4.1](#).

(2) Use this Conductor Category information for planning conductor routing as described in the appropriate System Level Installation Manual.

Environmental Specifications

Attribute	Value
Temperature, operating	IEC 60068-2-1 (Test Ad, Operating Cold), IEC 60068-2-2 (Test Bd, Operating Dry Heat), IEC 60068-2-14 (Test Nb, Operating Thermal Shock): 0 °C < Ta < +55 °C (+32 °F < Ta < +131 °F)
Temperature, ambient, max	60 °C (140 °F)
Temperature, surrounding air, max.	60 °C (140 °F)
Temperature, nonoperating	IEC 60068-2-1 (Test Ab, Unpackaged Nonoperating Cold), IEC 60068-2-2 (Test Bb, Unpackaged Nonoperating Dry Heat), IEC 60068-2-14 (Test Na, Unpackaged Nonoperating Thermal Shock): -40...+85 °C (-40...+185 °F)
Relative humidity	IEC 60068-2-30 (Test Db, Unpackaged Damp Heat): 5...95% noncondensing
Vibration	IEC60068-2-6 (Test Fc, Operating): 5 g @ 10...500 Hz
Shock, operating	EC 60068-2-27 (Test Ea, Unpackaged Shock): 30 g
Shock, nonoperating	EC 60068-2-27 (Test Ea, Unpackaged Shock): 50 g